

ROW SCANNING

2pcs x 74HC595
+
13pcs x Transistor A1013

COLUMN SCANNING

2pcs x TPIC6B595
Power Logic 8-Bit Shift Register

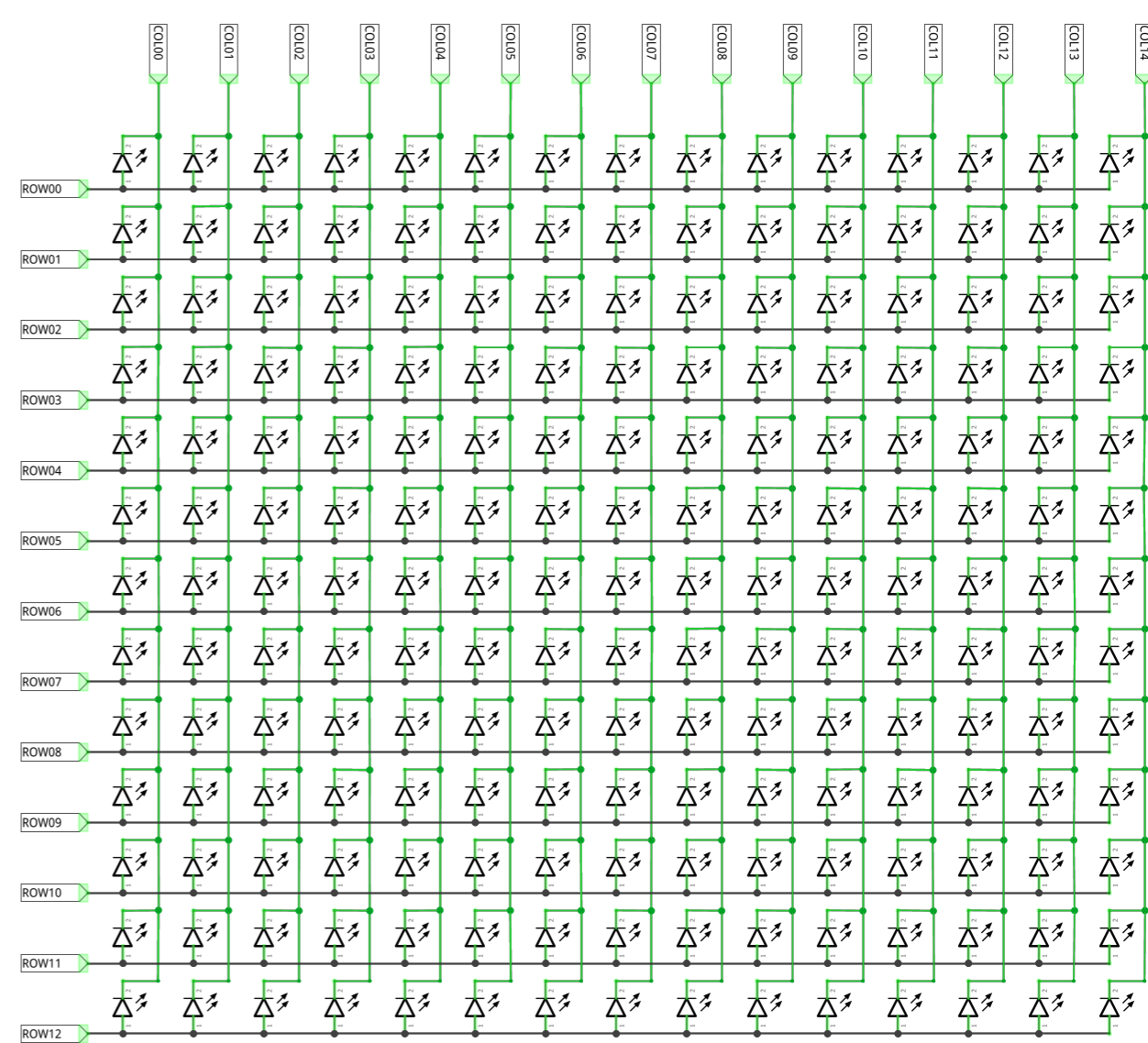

- * AMS1117 power module supply 3.3V to ESP8266-01.
- * The slide switch - S2 - allows switching between program and normal operation modes.
- * The button - S1 - is used to reset ESP8266-01.
- * The 6 PIN FEMALE HEADER is used for programming modes, FTDI programmer - 6 PIN MALE HEADER can plugged to it for uploading user program.

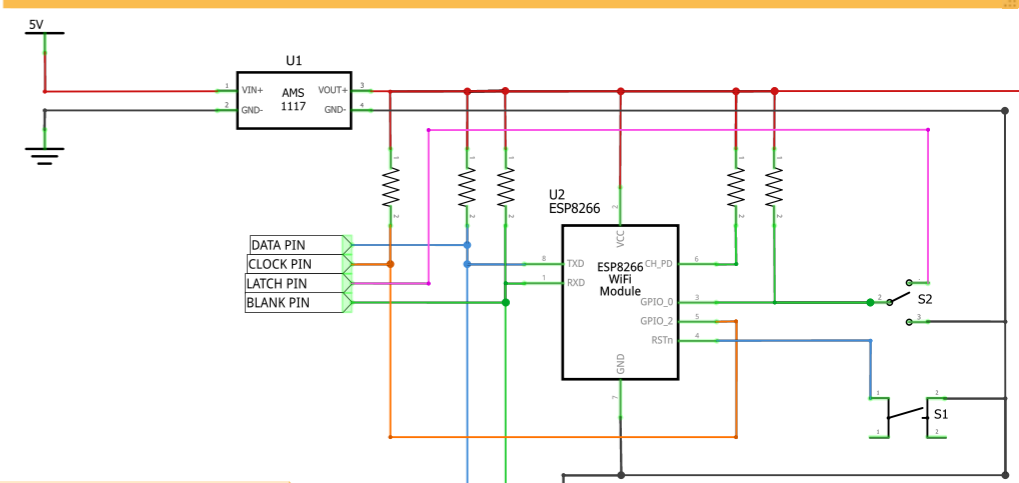
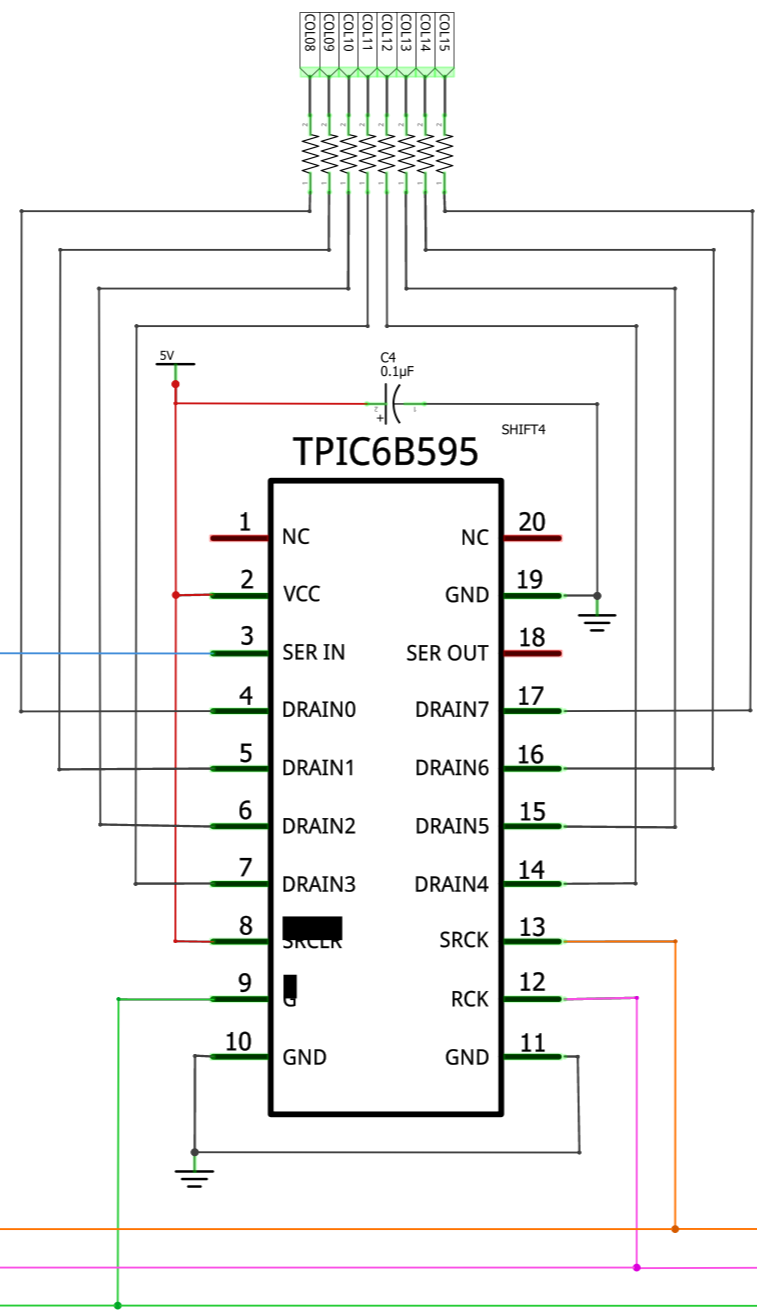
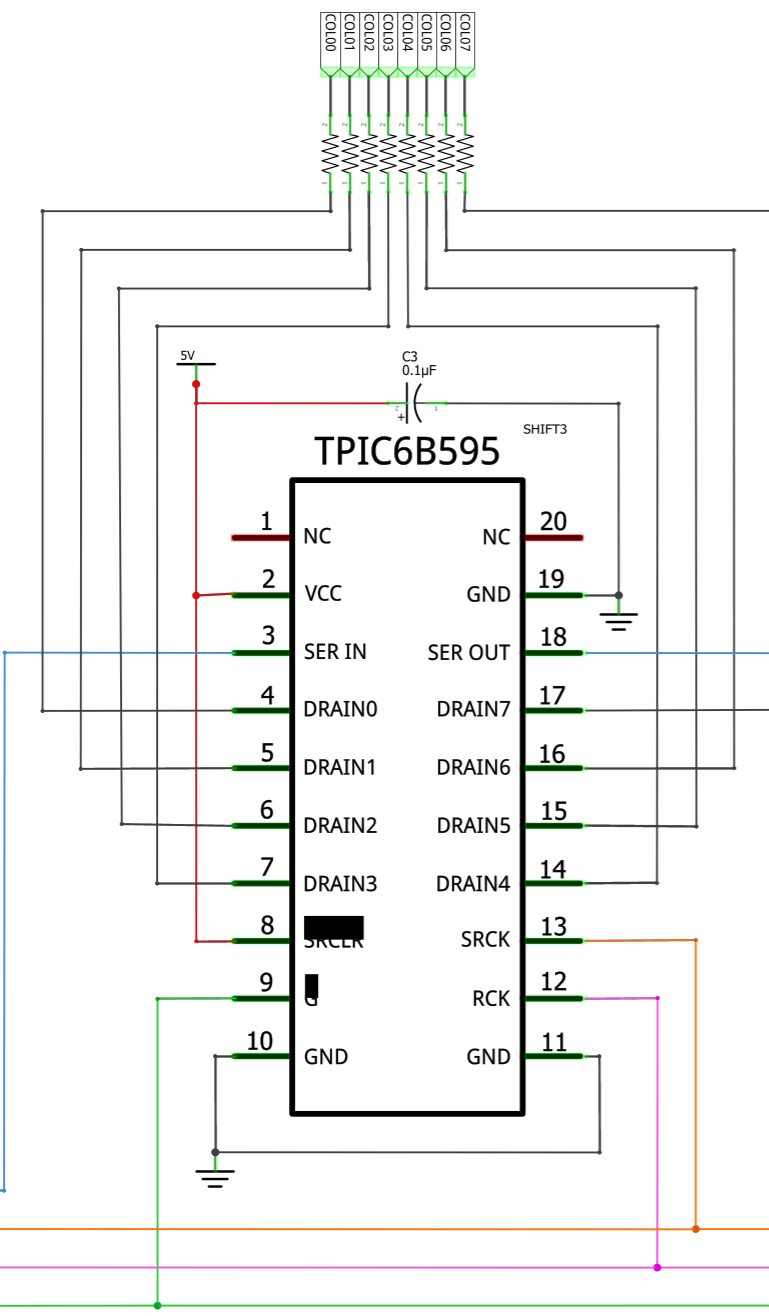

6 PIN MALE HEADER IS SOLDERED ON PROTOTYPE SO THAT ESP8266-01 CAN BE PROGRAMMED VIA THIS HEADER