

Build The Real McTube by Fred Nachbaur. Visit his website for more information on the Real McTube and other great projects: <http://www.dogstar.dantimax.dk/tubestuf/mctube.htm>. Isolate jacks from enclosure and ground enclosure to one point. We will remember you dearly Fred. Trademarks remain property of their owners. Visit tonepad.com for more!

Parts List

Resistors

- R1 - 2k2
- R2 - 12 ohm 2W *
- R3 - 1M
- R4 - 330k 1/2W
- R5 - 15k
- R6 - 680k 1/2W
- R7 - 4k7
- R8 - 1M
- R9 - 100k
- R10 - 470 ohm 1/2W

Pots

- RV1 - 500k Log
- RV2 - 500k Log

Diodes

- D1-D4 - 1N4004
- D5-D8 - 1N4001

Capacitors

- C1 - 33µF / 160v
- C2 - 33µF / 160v
- C3 - 2200µF / 16v
- C4 - 2200µF / 16v
- C5 - 0.01µF / 50v
- C6 - 0.02µF / 200v
- C7 - 100µF / 16v
- C8 - 0.02µF / 200v
- C9 - 100µF / 16v

Transformers

- T1 - 120v/12v 0.5A
- T2 - 120v/12v 0.5A

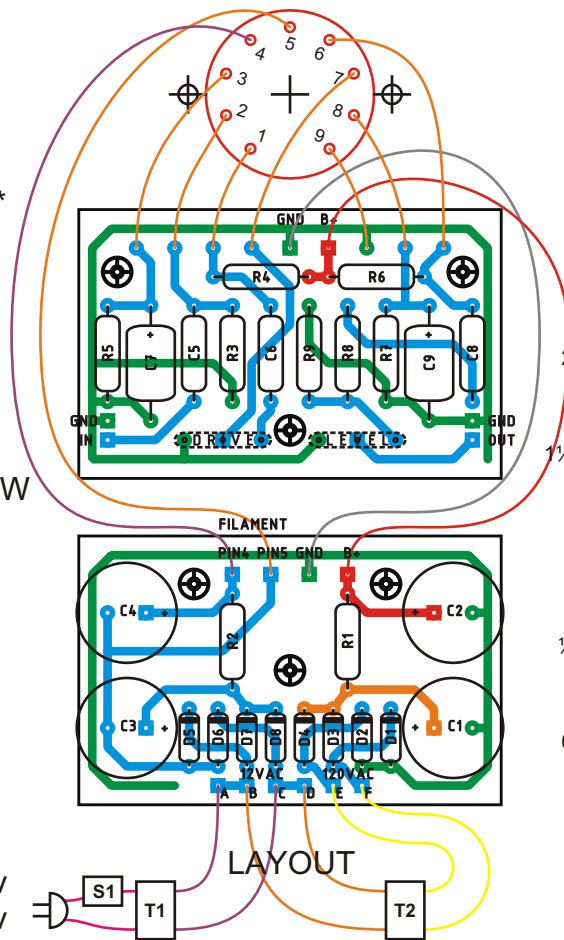

Notes:

- * R2 is reclining on one of it's ends, because of it's size it doesn't lay flat on the board.
- Use 3PDT switch for bypass.

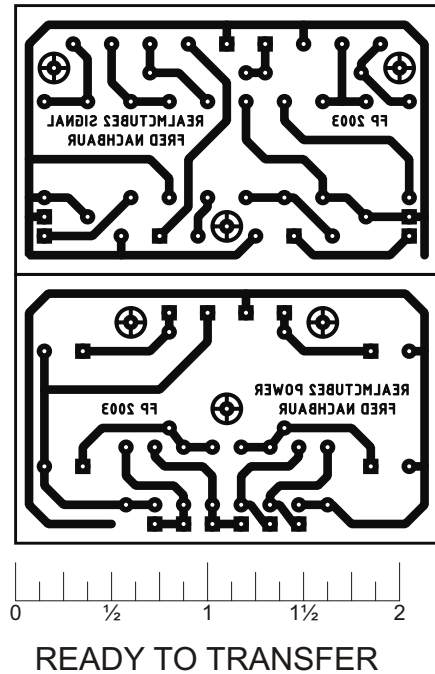

Schematic

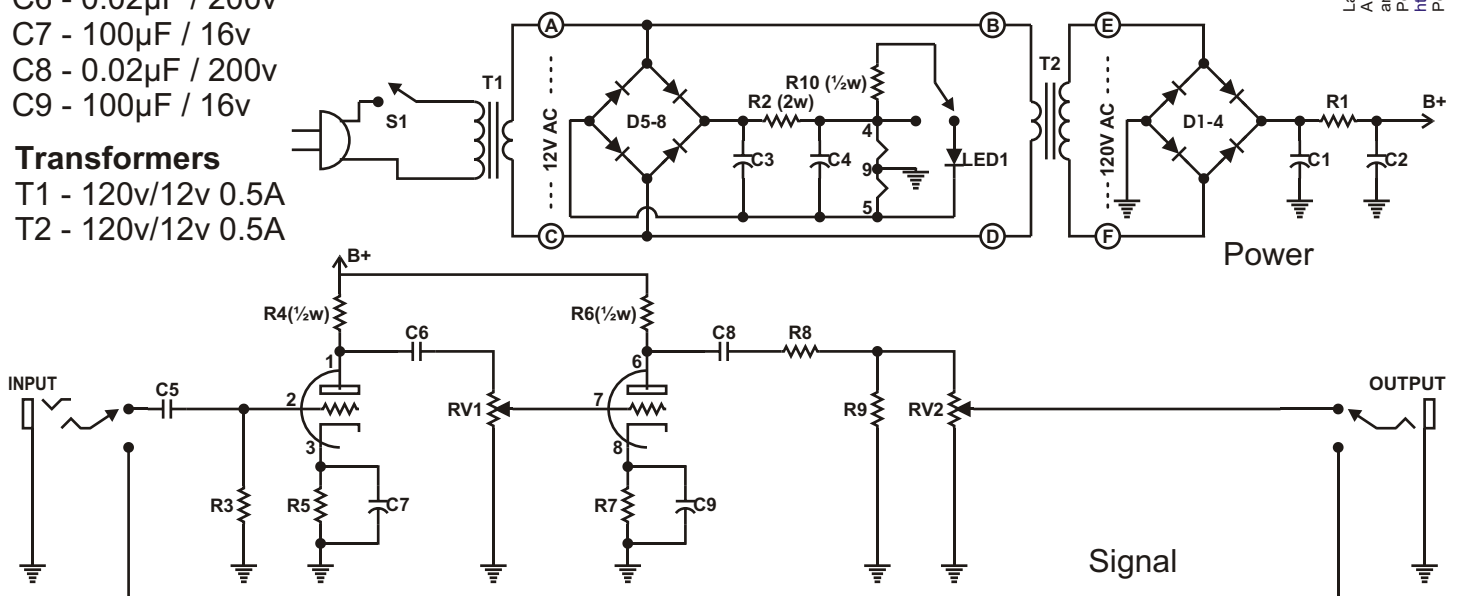

Layout and presentation by Francisco Peña 2003 - 2006®.
 All rights reserved. Authorization for personal use only.
 any commercial use is forbidden.
 Permission for posting/serving limited to
<http://www.tonepad.com/>
 Permission refused for posting from other sites.