

PART NO.

# THREADED ROD

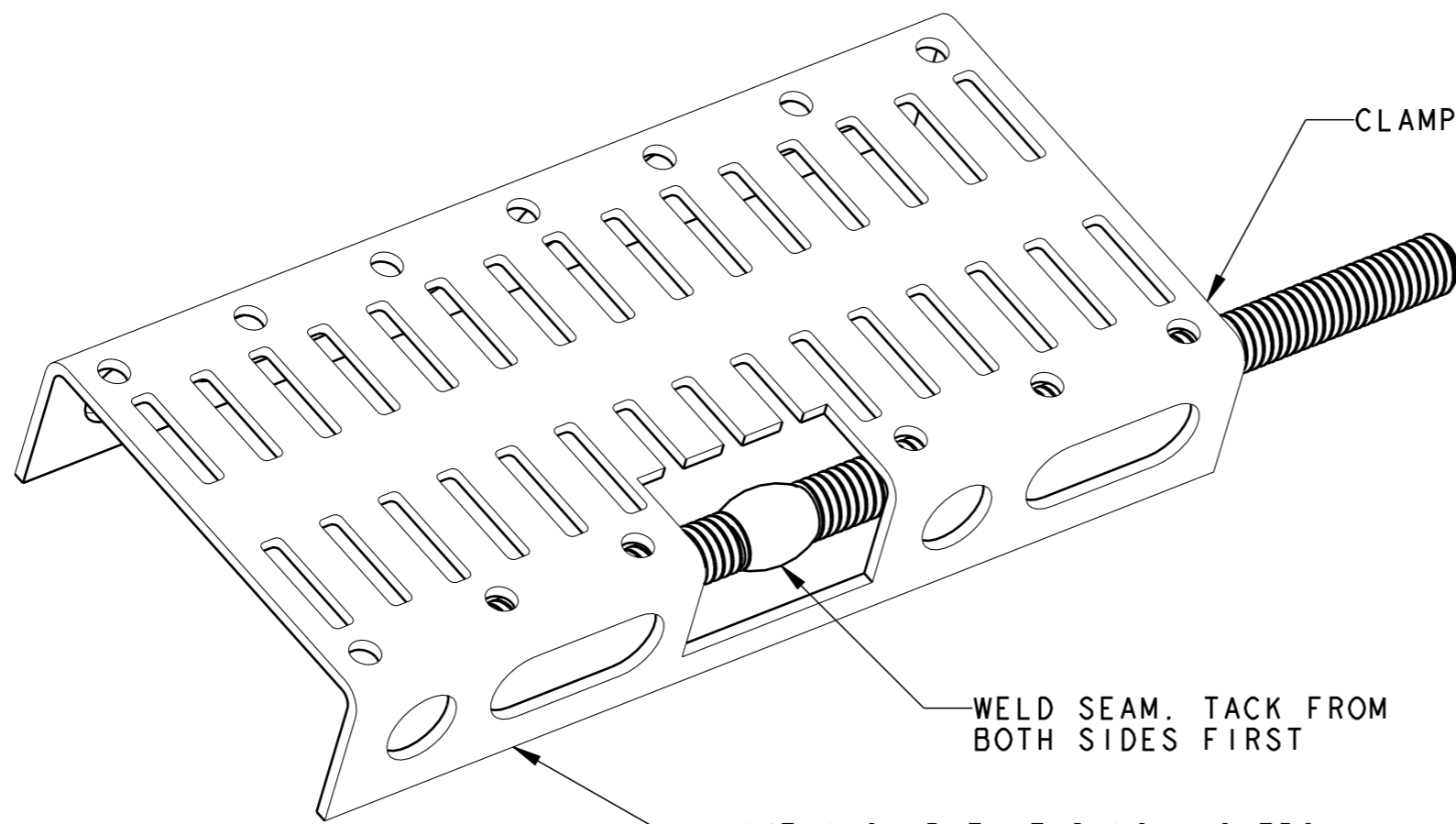
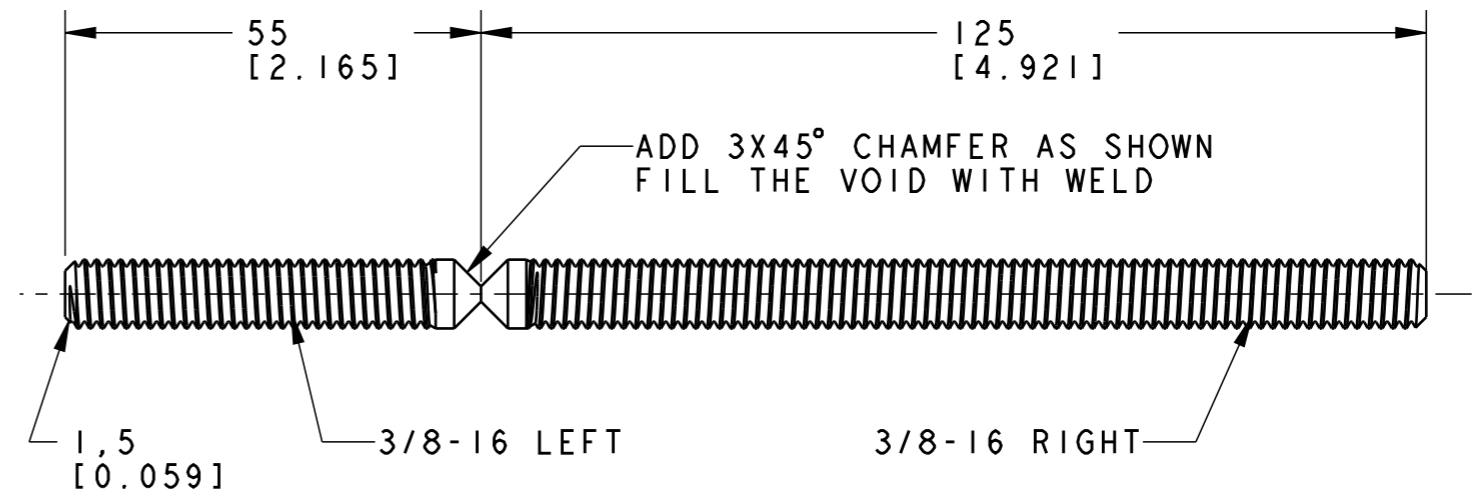

MAKE A SIMPLE WELDING JIG FROM LEFTOVER MATERIAL AS SHOWN. CUT A WINDOW SO YOU CAN HAVE ACCESS TO THE WELD FROM ALL SIDES

DIMENSIONS ARE IN MILLIMETERS U.O.S.

FROM 0.5 UP TO 3	OVER 3 UP TO 6	OVER 6 UP TO 30	OVER 30 UP TO 120	OVER 120 UP TO 400	OVER 400 UP TO 2000
±0.1	±0.1	±0.2	±0.3	±0.5	±0.8

**na**  
ENGINEERING

THIRD ANGLE PROJECTION

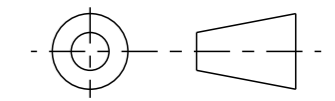

DR NAGY A	30JA12	MATERIAL	SCALE
CK NAGY A	30JA12	WHATEVER	1.0

TRUING STAND

PART NO.	ORG SIZE
<b>THREADED ROD</b>	<b>A3</b>