

Fascinating Friday Quilt Along

1/4 inch seam allowance

Week Six

Week 6 - Section 1

Cutting Chart – Darks

Block C – $1\frac{1}{2} \times 1\frac{1}{2}$

Block D – $1\frac{1}{2} \times 1\frac{1}{2}$

Block F – $5\frac{1}{2} \times 1\frac{1}{2}$

Cutting Chart – Lights

Block A – $2\frac{1}{2} \times 1\frac{1}{2}$

Block B – $1\frac{1}{2} \times 1\frac{1}{2}$

Block E – $4\frac{1}{2} \times 1\frac{1}{2}$

Block G – $7\frac{1}{2} \times 7\frac{1}{2}$

Assembly

Sew Block B to Block C and attach to the bottom of Block A

Sew Block D to Block E and attach to the top of Block F

Sew Unit A-C to the left of Unit D-F then attach this to the bottom of Block G

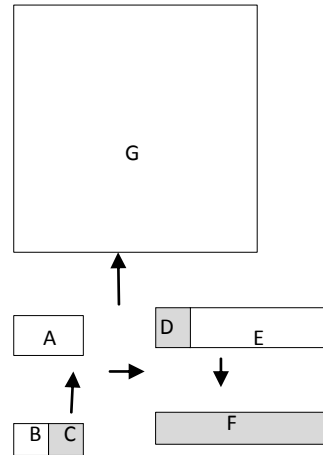

Section 1 finished size $7\frac{1}{2} \times 9\frac{1}{2}$

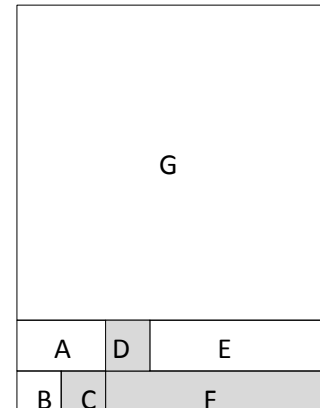

Week 6 – Section 2

Cutting Chart – Darks

Block I – $1\frac{1}{2} \times 1\frac{1}{2}$

Block J – $5\frac{1}{2} \times 4\frac{1}{2}$

Block K – $6\frac{1}{2} \times 5\frac{1}{2}$

Cutting Chart – Lights

Block H – $1\frac{1}{2} \times 3\frac{1}{2}$

Assembly

Sew Block H to Block I and attach to the left of Block J

Attach Unit H-J to the bottom of Block K

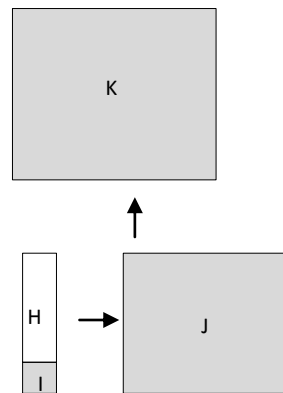

Section 2 finished size $6\frac{1}{2} \times 9\frac{1}{2}$

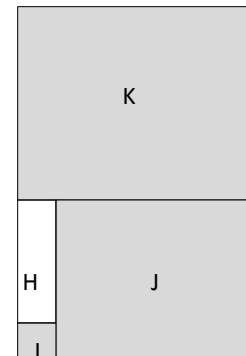

Sew Section 1 to the left side of Section 2

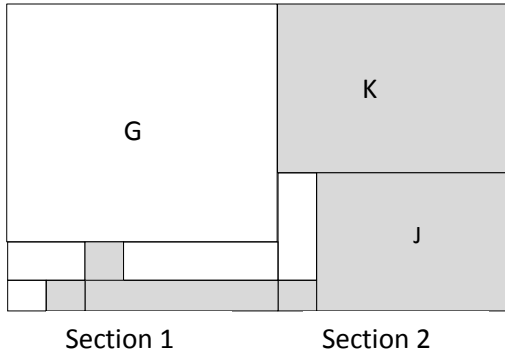

Then sew section 1-2 to the right side of already completed week 5 that is pinned to the design wall

Pin this new unit to the design wall. Do not sew to Week 4.

Week 6 – Section 3

Cutting Chart – Darks

Block L – $1\frac{1}{2} \times 2\frac{1}{2}$

Block N – $1\frac{1}{2} \times 2\frac{1}{2}$

Block O – $2\frac{1}{2} \times 3\frac{1}{2}$

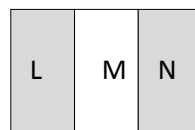

Section 3 finished size $3\frac{1}{2} \times 5\frac{1}{2}$

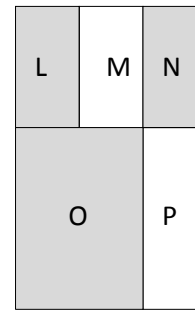

Cutting Chart – Lights

Block M – $1\frac{1}{2} \times 2\frac{1}{2}$

Block P – $1\frac{1}{2} \times 3\frac{1}{2}$

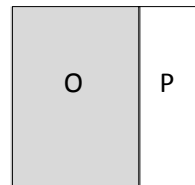

Assembly

Working from left to right sew Block L, M and N together to make a row
Sew Block O to Block P then attach to the bottom of Unit L-M and set aside

Week 6 – Section 4

Cutting Chart – Darks

Block Q – $1\frac{1}{2} \times 1\frac{1}{2}$

Block S – $4\frac{1}{2} \times 4\frac{1}{2}$

Block U – $4\frac{1}{2} \times 1\frac{1}{2}$

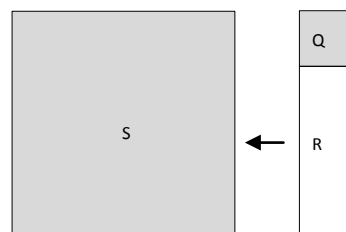

Section 4 finished size $5\frac{1}{2} \times 5\frac{1}{2}$

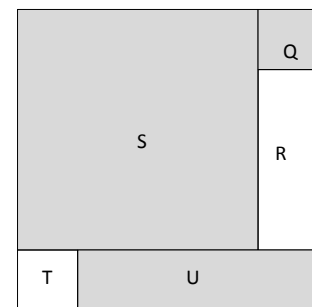

Cutting Chart – Lights

Block R – $1\frac{1}{2} \times 3\frac{1}{2}$

Block T – $1\frac{1}{2} \times 1\frac{1}{2}$

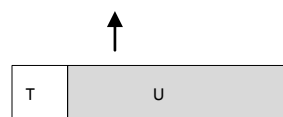

Assembly

Sew Block Q to Block R and attach to the right side of Block S
Sew Block T to Block U and attach to the bottom of Unit Q-S
Sew Section 4 to the right side of the already completed Section 3 and set aside. *We are making a long row with sections 3-8*

Week 6 – Section 5

Important Note: Sections 5-7 are the eye area. If you use red as your dark fabric color it will photograph as “red eye”.

Cutting Chart – Darks

Block X – $1\frac{1}{2} \times 2\frac{1}{2}$

Block W – $1\frac{1}{2} \times 2\frac{1}{2}$

Cutting Chart – Lights

Block AA – $3\frac{1}{2} \times 5\frac{1}{2}$

Block V – $1\frac{1}{2} \times 1\frac{1}{2}$

Block Y – $1\frac{1}{2} \times 1\frac{1}{2}$

Block Z – $2\frac{1}{2} \times 2\frac{1}{2}$

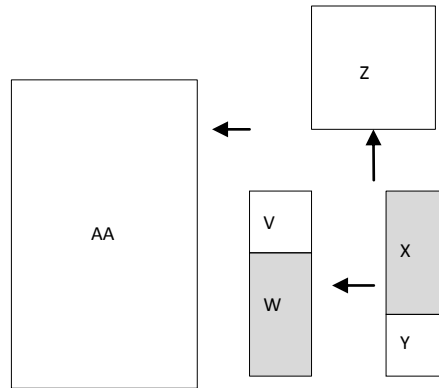

Section 5 finished size $5\frac{1}{2} \times 5\frac{1}{2}$

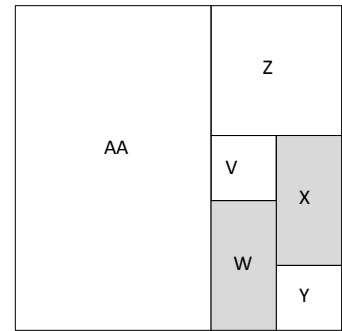

Assembly

Sew Block V to Block W

Sew Block X to Block Y then attach to the right side of Unit V/W

Sew this to the bottom of Block Z

Sew Unit V-Z to the right of Block AA

Sew section 5 to the right side of the already completed section 4 and set aside

Week 6 – Section 6

Note: Starting the alphabet over

Cutting Chart – Darks

Block B – $3\frac{1}{2} \times 1\frac{1}{2}$

Block C – $5\frac{1}{2} \times 2\frac{1}{2}$

Block D – $1\frac{1}{2} \times 1\frac{1}{2}$

Cutting Chart – Lights

Block A – $2\frac{1}{2} \times 1\frac{1}{2}$

Block E – $1\frac{1}{2} \times 1\frac{1}{2}$

Block G – $3\frac{1}{2} \times 2\frac{1}{2}$

Block F – $1\frac{1}{2} \times 2\frac{1}{2}$

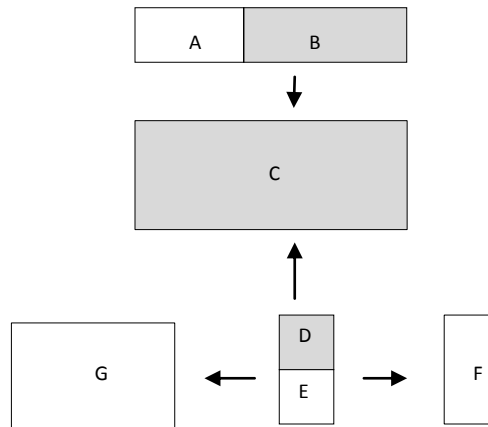

Section 6 finished size $5\frac{1}{2} \times 5\frac{1}{2}$

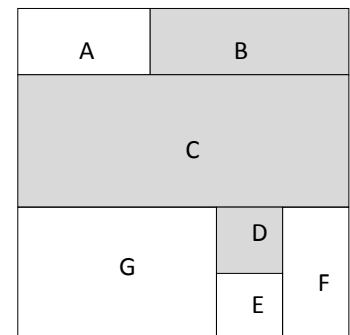

Assembly

Sew Block A to Block B and attach to the top of Block C

Sew Block D to Block E and attach to the left of Block F and the right of Block G

Sew Unit A-C to the top of Unit G-F

Sew Section 6 to the right side of the already completed section 5 and set aside

Week 6 – Section 7

Cutting Chart – Darks

Block H – $1\frac{1}{2} \times 1\frac{1}{2}$

Block J – $3\frac{1}{2} \times 2\frac{1}{2}$

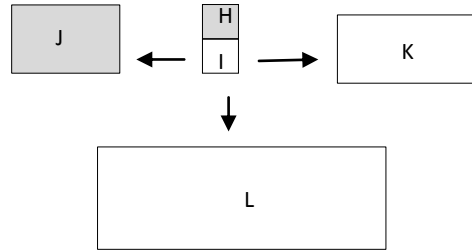

Section 7 finished size $8\frac{1}{2} \times 5\frac{1}{2}$

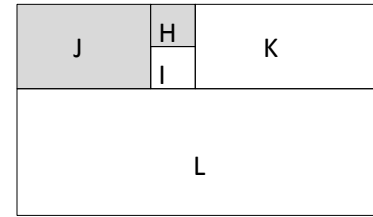

Cutting Chart – Lights

Block I – $1\frac{1}{2} \times 1\frac{1}{2}$

Block K – $4\frac{1}{2} \times 2\frac{1}{2}$

Block L – $8\frac{1}{2} \times 3\frac{1}{2}$

Assembly

Sew Block H to Block I

Sew Block K to the right and Block J to the left

Sew unit H-K to the top of Block L

Sew section 7 to the right side of the already completed section 6 and set aside

Week 6 – Section 8

Cutting Chart – Darks

Block N – $5\frac{1}{2} \times 2\frac{1}{2}$

Block T – $5\frac{1}{2} \times 3\frac{1}{2}$

Block P – $1\frac{1}{2} \times 2\frac{1}{2}$

Block R – $1\frac{1}{2} \times 1\frac{1}{2}$

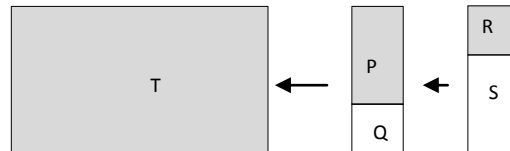

Section 8 finished size $7\frac{1}{2} \times 5\frac{1}{2}$

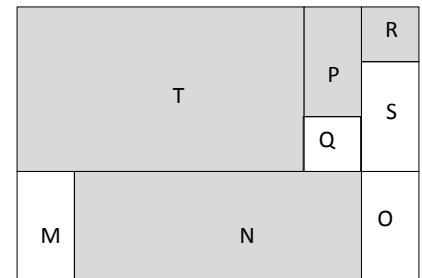

Cutting Chart – Lights

Block M – $1\frac{1}{2} \times 2\frac{1}{2}$

Block O – $1\frac{1}{2} \times 2\frac{1}{2}$

Block Q – $1\frac{1}{2} \times 1\frac{1}{2}$

Block S – $1\frac{1}{2} \times 2\frac{1}{2}$

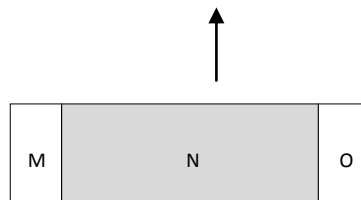

Assembly

Sew Block P to Block Q

Sew Block R to Block S then attach to the right of Unit P/Q

Sew Unit P-S to the right of Block T

Working from left to right sew Block M, Block N and Block O in a row then attach to the bottom of Unit P-T

Sew Section 8 to the right side of the already completed section 7 to finish the row.

Sew this row (sections 3-8) to the top of Week 5 & Week 6 that are on the design wall

Pin this finished section to the design wall. Do not sew it in place yet.

