

# Open Source

## Flashlight Kit

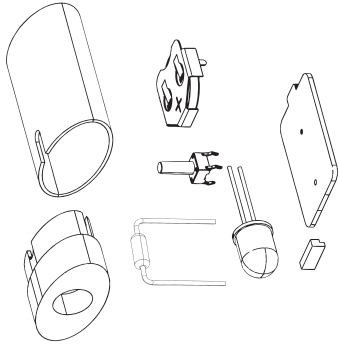

bit.ly/osflashlight



### Instructions (Part 2):

5) Install LED and use the lead bending tool as a spacer to hold the LED in the correct position (note the long lead):

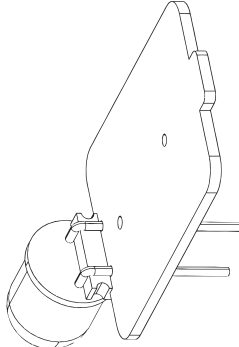

- 6) Remove lead spacer after soldering.
- 7) Trim long leads on Resistor and LED.
- 8) Install battery and test!
- 9) If finished remove 3D printed "body" and "cap" from 3D printer.

# Open Source

## Flashlight Kit

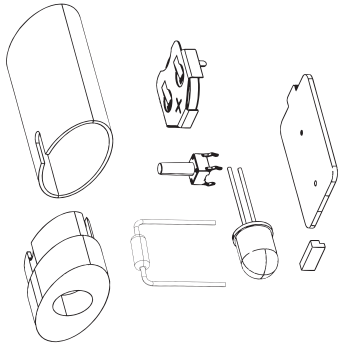

bit.ly/osflashlight



### Instructions (Part 2):

5) Install LED and use the lead bending tool as a spacer to hold the LED in the correct position (note the long lead):

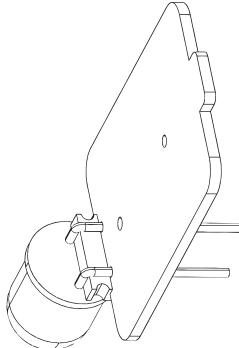

- 6) Remove lead spacer after soldering.
- 7) Trim long leads on Resistor and LED.
- 8) Install battery and test!
- 9) If finished remove 3D printed "body" and "cap" from 3D printer.

# Open Source

## Flashlight Kit

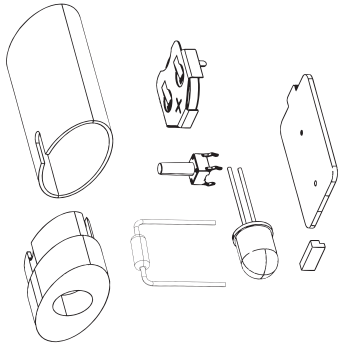

bit.ly/osflashlight



### Instructions (Part 2):

5) Install LED and use the lead bending tool as a spacer to hold the LED in the correct position (note the long lead):

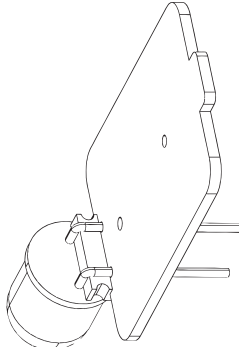

- 6) Remove lead spacer after soldering.
- 7) Trim long leads on Resistor and LED.
- 8) Install battery and test!
- 9) If finished remove 3D printed "body" and "cap" from 3D printer.

# Open Source

## Flashlight Kit

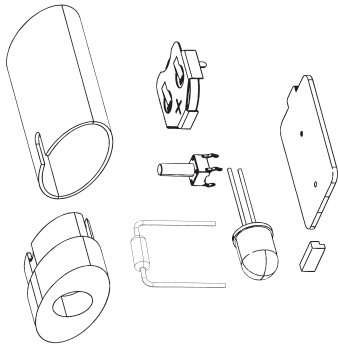

bit.ly/osflashlight



### Instructions (Part 2):

5) Install LED and use the lead bending tool as a spacer to hold the LED in the correct position (note the long lead):

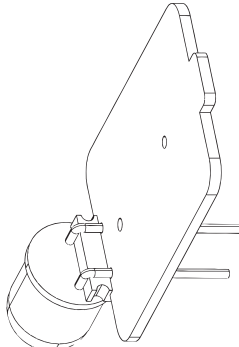

- 6) Remove lead spacer after soldering.
- 7) Trim long leads on Resistor and LED.
- 8) Install battery and test!
- 9) If finished remove 3D printed "body" and "cap" from 3D printer.

# Open Source

## Flashlight Kit

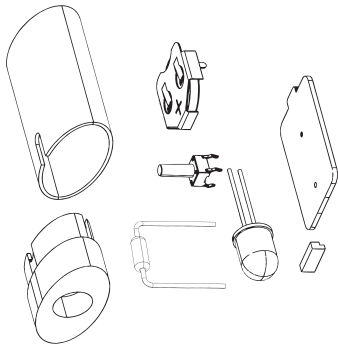

bit.ly/osflashlight



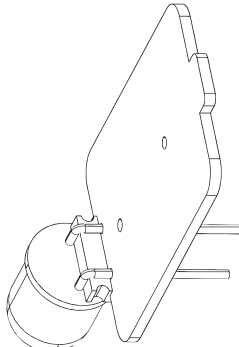

### Instructions (Part 2):

5) Install LED and use the lead bending tool as a spacer to hold the LED in the correct position (note the long lead):

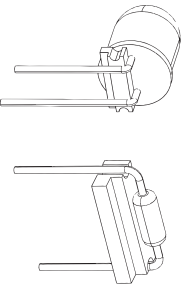
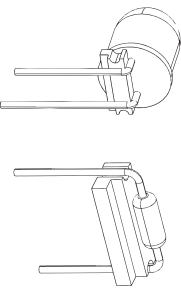
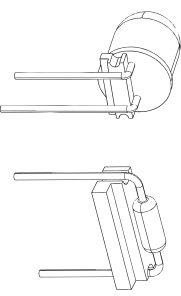
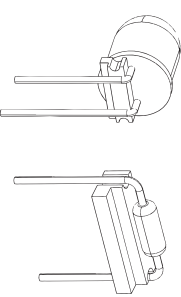
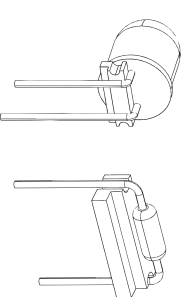
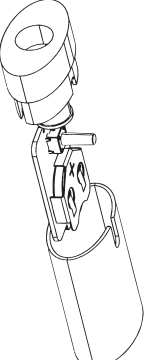
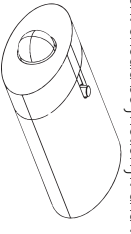
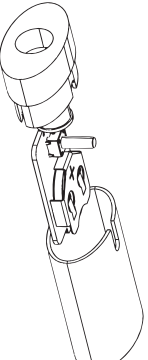

- 6) Remove lead spacer after soldering.
- 7) Trim long leads on Resistor and LED.
- 8) Install battery and test!
- 9) If finished remove 3D printed "body" and "cap" from 3D printer.

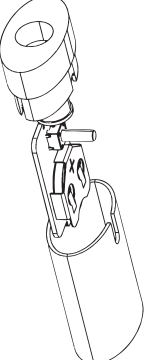
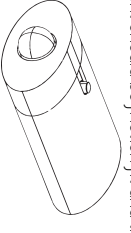
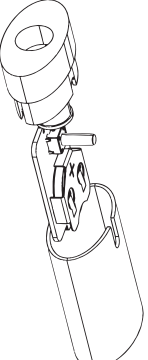
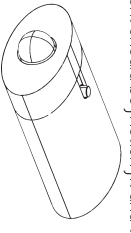
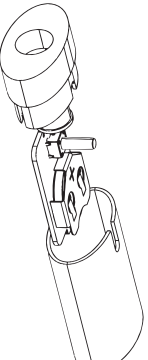
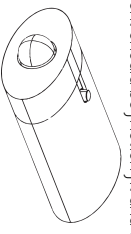
|  |  |   |  |  |  |  |  |  |  |
|--|--|---|--|--|--|--|--|--|--|
| <p>Instructions(Part 1):</p> <ol style="list-style-type: none"> <li>1) Download STL files from <a href="http://bit.ly/osflashlight">bit.ly/osflashlight</a> and 3D Print "lead_bending_tool.stl"</li> <li>2) Use the tool to bend leads on the led and resistor (shown below).</li> </ol>  <ol style="list-style-type: none"> <li>3) Start 3D printing "flashlight_body.stl" and "flashlight_cap.stl"</li> <li>4) While printing solder components: <ul style="list-style-type: none"> <li>R1 - Resistor</li> <li>SW1 - Push Button</li> <li>P1 - Battery Holder</li> </ul> </li> </ol> | <p>Instructions(Part 1):</p> <ol style="list-style-type: none"> <li>1) Download STL files from <a href="http://bit.ly/osflashlight">bit.ly/osflashlight</a> and 3D Print "lead_bending_tool.stl"</li> <li>2) Use the tool to bend leads on the led and resistor (shown below).</li> </ol>  <ol style="list-style-type: none"> <li>3) Start 3D printing "flashlight_body.stl" and "flashlight_cap.stl"</li> <li>4) While printing solder components: <ul style="list-style-type: none"> <li>R1 - Resistor</li> <li>SW1 - Push Button</li> <li>P1 - Battery Holder</li> </ul> </li> </ol> | <p>Instructions(Part 1):</p> <ol style="list-style-type: none"> <li>1) Download STL files from <a href="http://bit.ly/osflashlight">bit.ly/osflashlight</a> and 3D Print "lead_bending_tool.stl"</li> <li>2) Use the tool to bend leads on the led and resistor (shown below).</li> </ol>  <ol style="list-style-type: none"> <li>3) Start 3D printing "flashlight_body.stl" and "flashlight_cap.stl"</li> <li>4) While printing solder components: <ul style="list-style-type: none"> <li>R1 - Resistor</li> <li>SW1 - Push Button</li> <li>P1 - Battery Holder</li> </ul> </li> </ol> | <p>Instructions(Part 1):</p> <ol style="list-style-type: none"> <li>1) Download STL files from <a href="http://bit.ly/osflashlight">bit.ly/osflashlight</a> and 3D Print "lead_bending_tool.stl"</li> <li>2) Use the tool to bend leads on the led and resistor (shown below).</li> </ol>  <ol style="list-style-type: none"> <li>3) Start 3D printing "flashlight_body.stl" and "flashlight_cap.stl"</li> <li>4) While printing solder components: <ul style="list-style-type: none"> <li>R1 - Resistor</li> <li>SW1 - Push Button</li> <li>P1 - Battery Holder</li> </ul> </li> </ol> | <p>Instructions(Part 1):</p> <ol style="list-style-type: none"> <li>1) Download STL files from <a href="http://bit.ly/osflashlight">bit.ly/osflashlight</a> and 3D Print "lead_bending_tool.stl"</li> <li>2) Use the tool to bend leads on the led and resistor (shown below).</li> </ol>  <ol style="list-style-type: none"> <li>3) Start 3D printing "flashlight_body.stl" and "flashlight_cap.stl"</li> <li>4) While printing solder components: <ul style="list-style-type: none"> <li>R1 - Resistor</li> <li>SW1 - Push Button</li> <li>P1 - Battery Holder</li> </ul> </li> </ol> | <p>Instructions(Part 3):</p> <ol style="list-style-type: none"> <li>10) Install Complete PCB into flashlight body. The end of the PCB will sit in a pocket in the base of the part.</li> </ol>  <ol style="list-style-type: none"> <li>11) Push on cap of flashlight while aligning LED and PCB in the slots of the cap. Firmest should be friction fit and tight.</li> </ol>  <p>For Video Instructions Visit: <a href="http://bit.ly/osflashlight">bit.ly/osflashlight</a></p> | <p>Instructions(Part 3):</p> <ol style="list-style-type: none"> <li>10) Install Complete PCB into flashlight body. The end of the PCB will sit in a pocket in the base of the part.</li> </ol>  <ol style="list-style-type: none"> <li>11) Push on cap of flashlight while aligning LED and PCB in the slots of the cap. Firmest should be friction fit and tight.</li> </ol>  <p>For Video Instructions Visit: <a href="http://bit.ly/osflashlight">bit.ly/osflashlight</a></p> | <p>Instructions(Part 3):</p> <ol style="list-style-type: none"> <li>10) Install Complete PCB into flashlight body. The end of the PCB will sit in a pocket in the base of the part.</li> </ol>  <ol style="list-style-type: none"> <li>11) Push on cap of flashlight while aligning LED and PCB in the slots of the cap. Firmest should be friction fit and tight.</li> </ol>  <p>For Video Instructions Visit: <a href="http://bit.ly/osflashlight">bit.ly/osflashlight</a></p> | <p>Instructions(Part 3):</p> <ol style="list-style-type: none"> <li>10) Install Complete PCB into flashlight body. The end of the PCB will sit in a pocket in the base of the part.</li> </ol>  <ol style="list-style-type: none"> <li>11) Push on cap of flashlight while aligning LED and PCB in the slots of the cap. Firmest should be friction fit and tight.</li> </ol>  <p>For Video Instructions Visit: <a href="http://bit.ly/osflashlight">bit.ly/osflashlight</a></p> | <p>Instructions(Part 3):</p> <ol style="list-style-type: none"> <li>10) Install Complete PCB into flashlight body. The end of the PCB will sit in a pocket in the base of the part.</li> </ol>  <ol style="list-style-type: none"> <li>11) Push on cap of flashlight while aligning LED and PCB in the slots of the cap. Firmest should be friction fit and tight.</li> </ol>  <p>For Video Instructions Visit: <a href="http://bit.ly/osflashlight">bit.ly/osflashlight</a></p> |
|--|--|---|--|--|--|--|--|--|--|