

# Bill Of Material

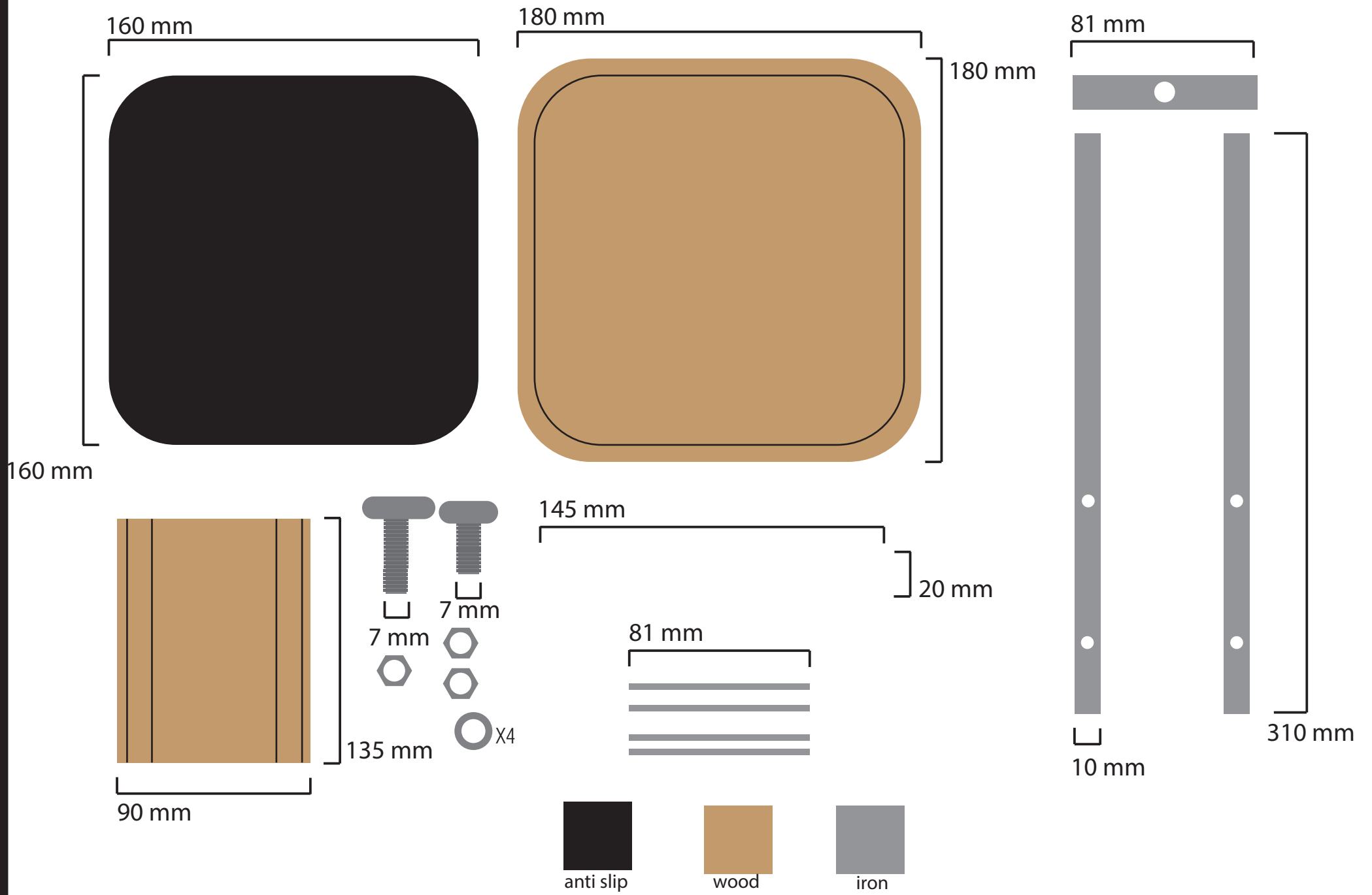

# Tools And Actions



welding



drilling

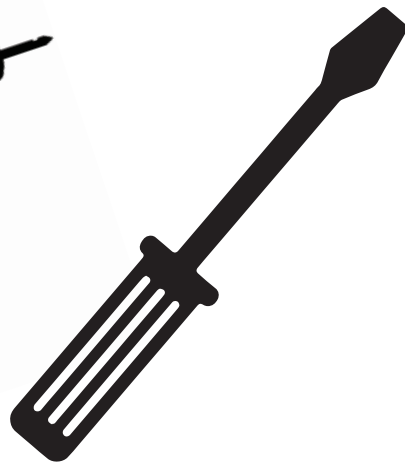

screwing



Glue



hammer

# For The CNC

1

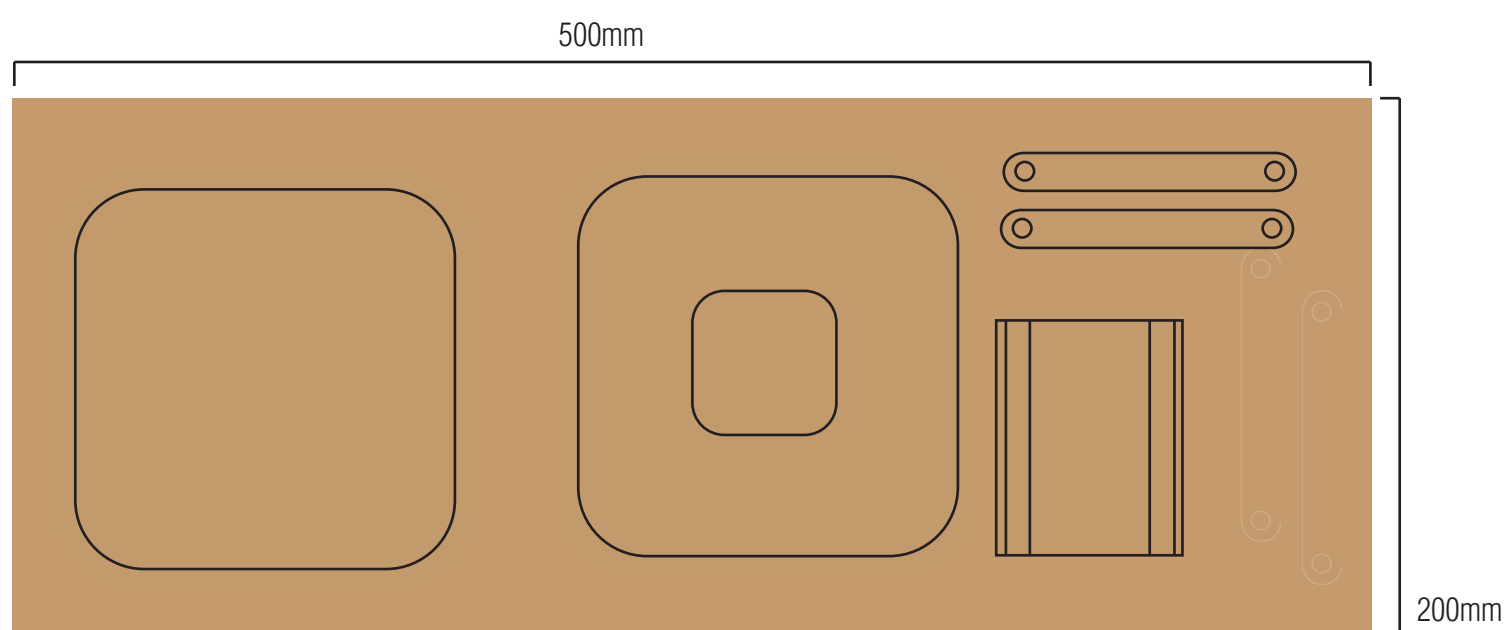

- prepare Beech wood 500X200 mm 20 mm thick
- use the stl file for the CNC.

2

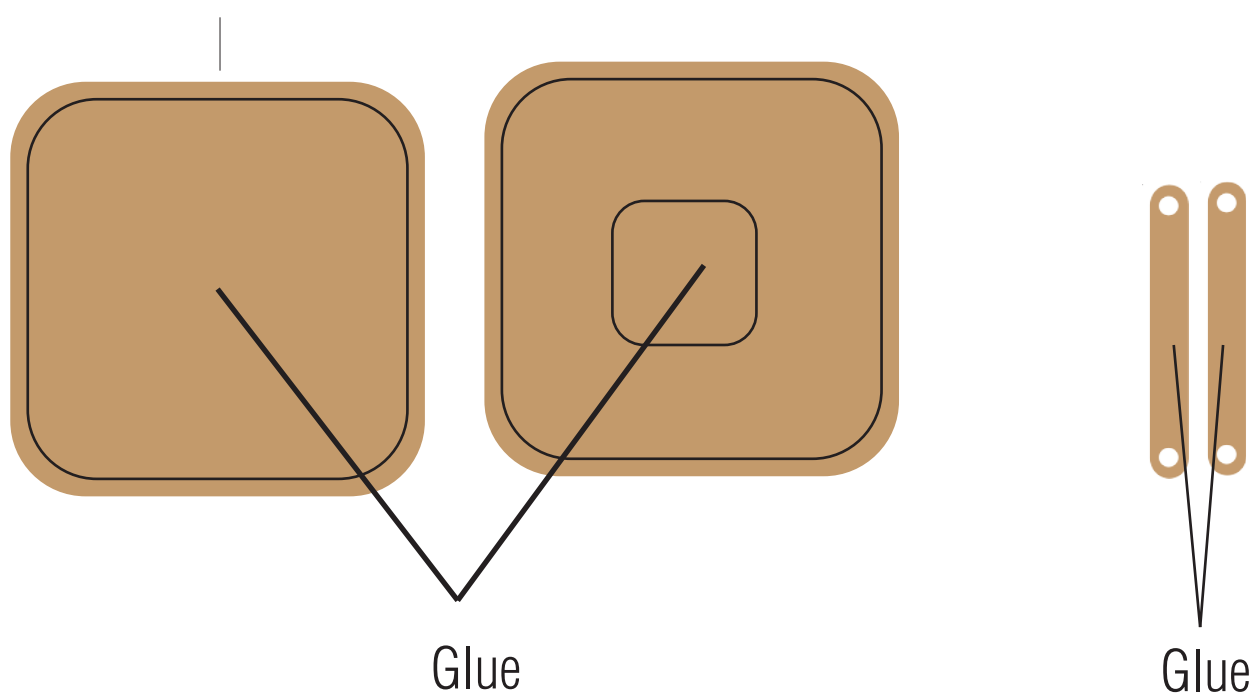

- glue the two flat surfaces one to the other, of both the arm and the tray.

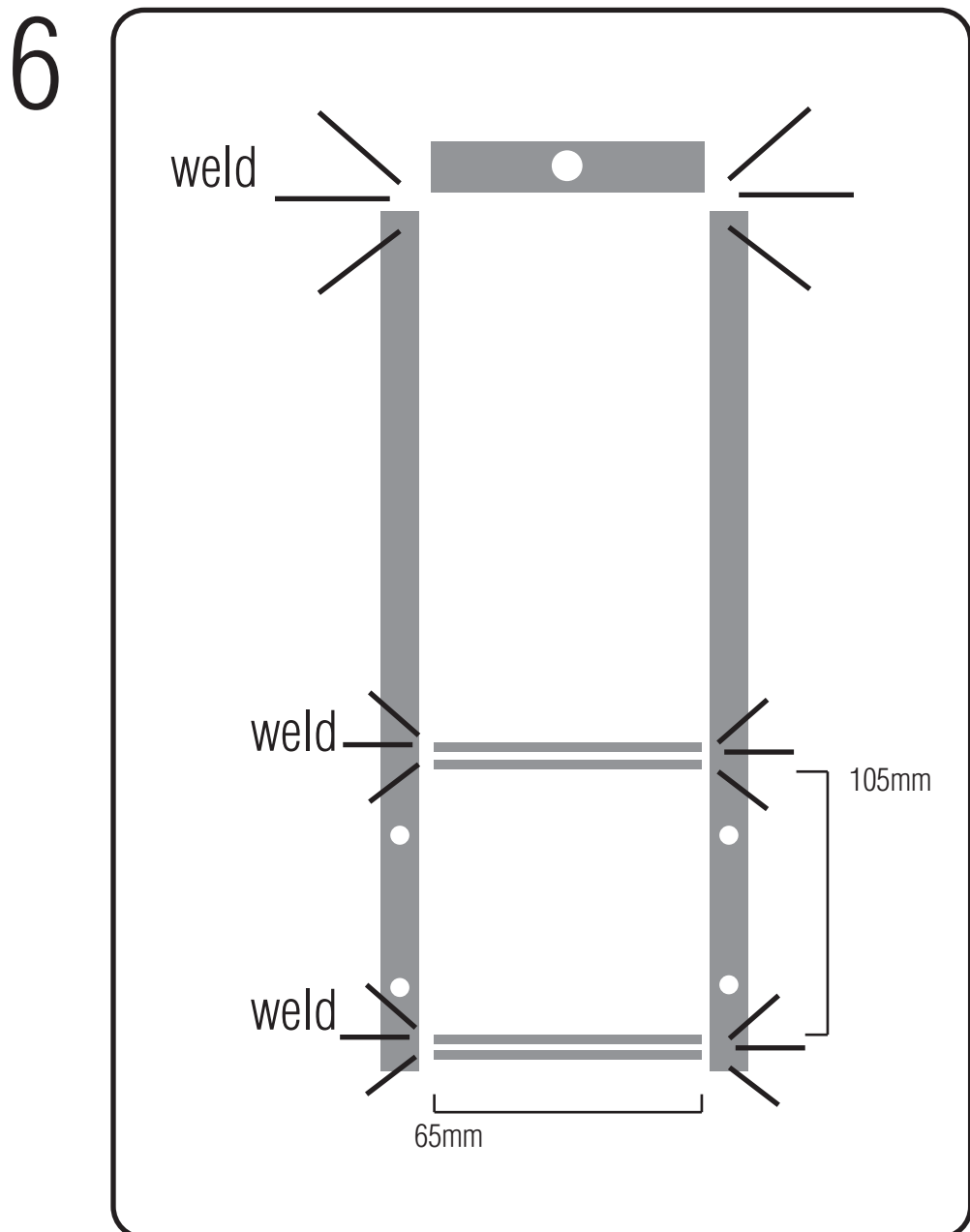
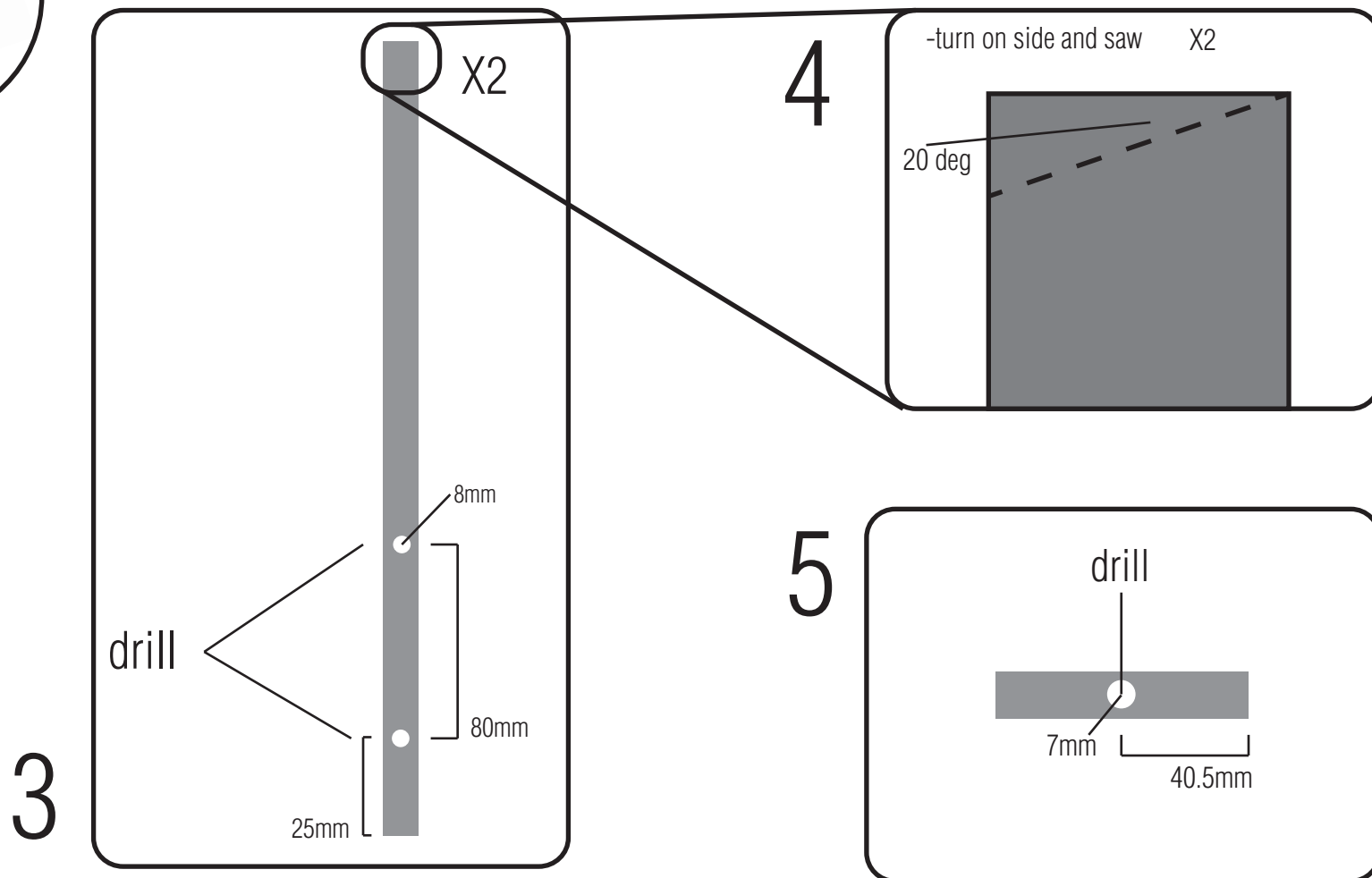

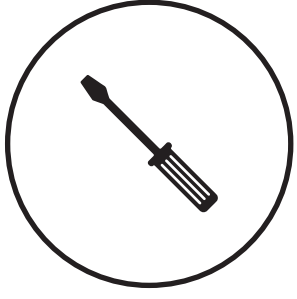

7

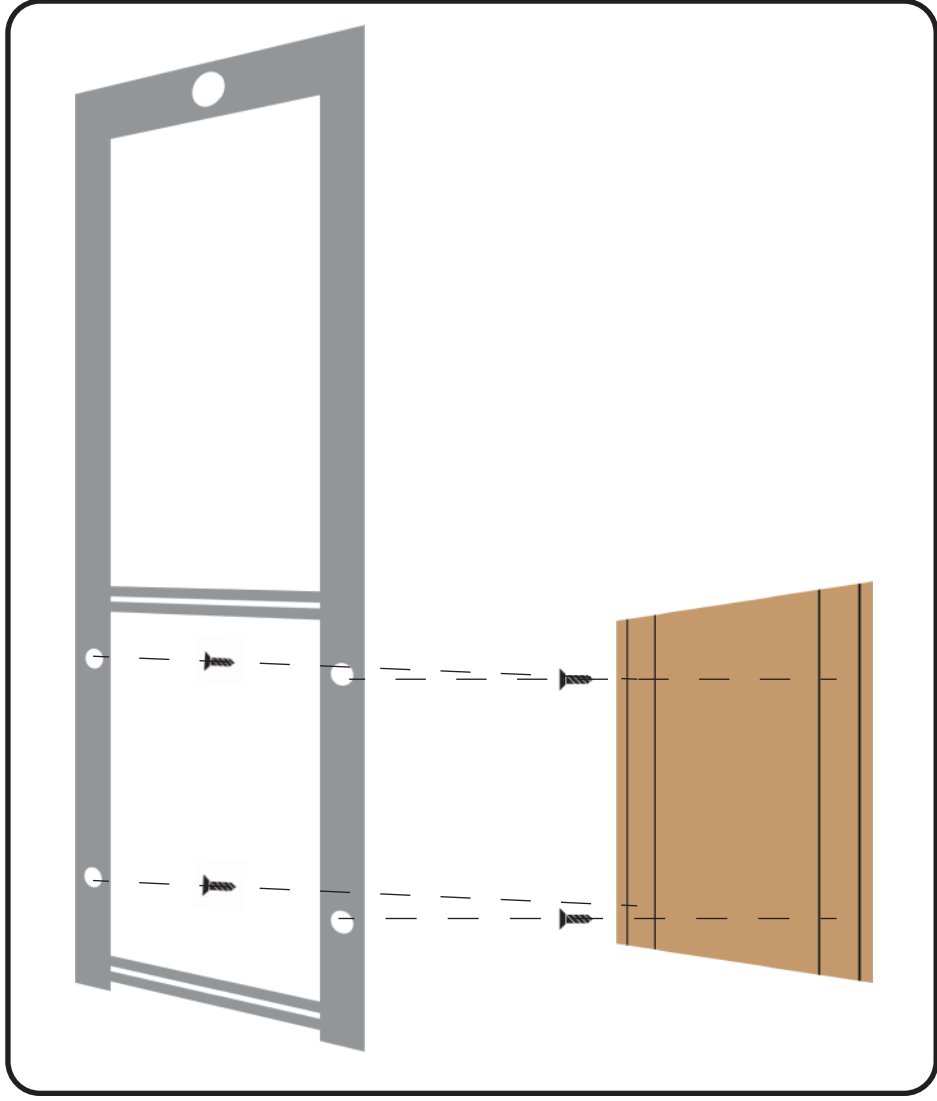

8

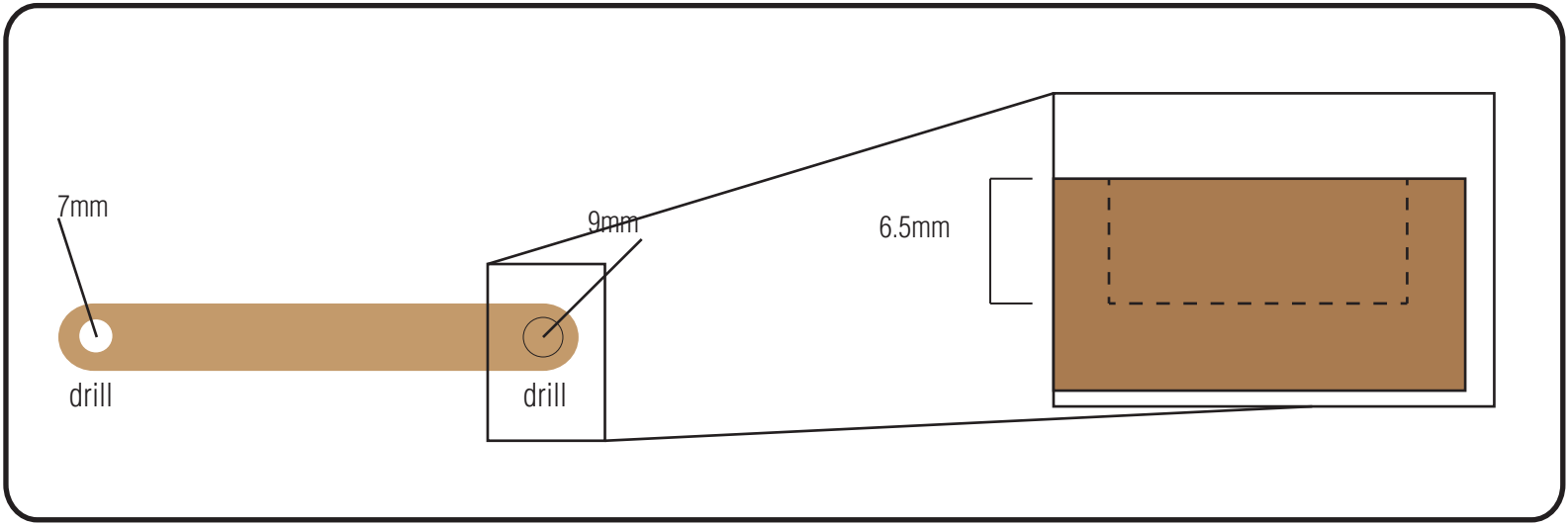

9

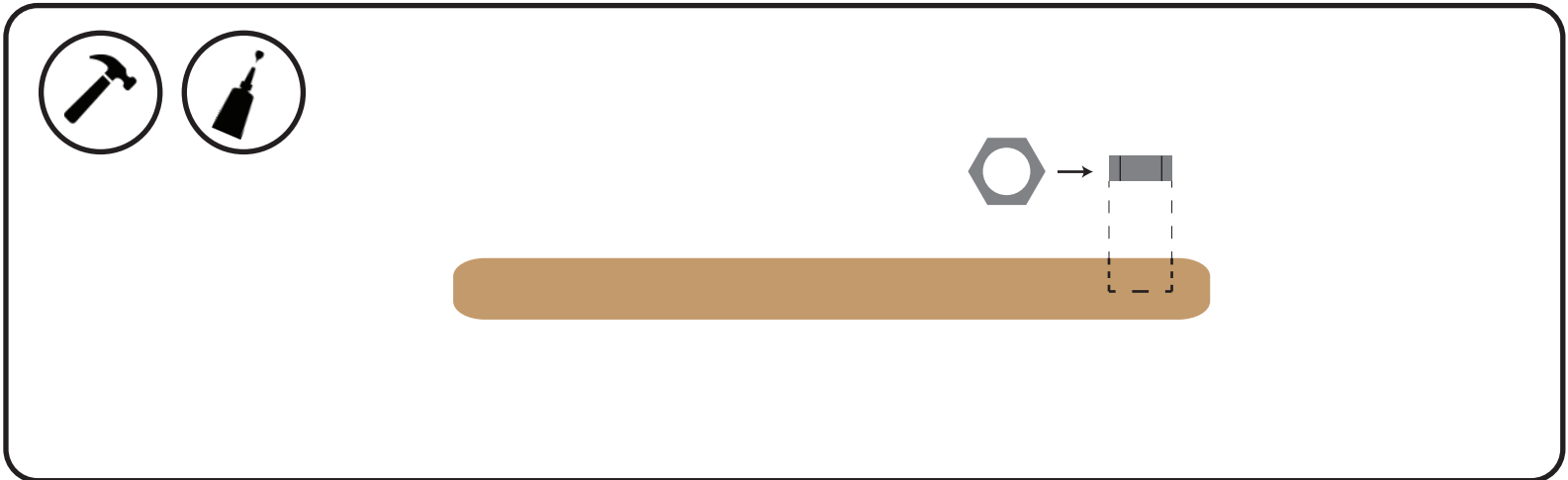



10

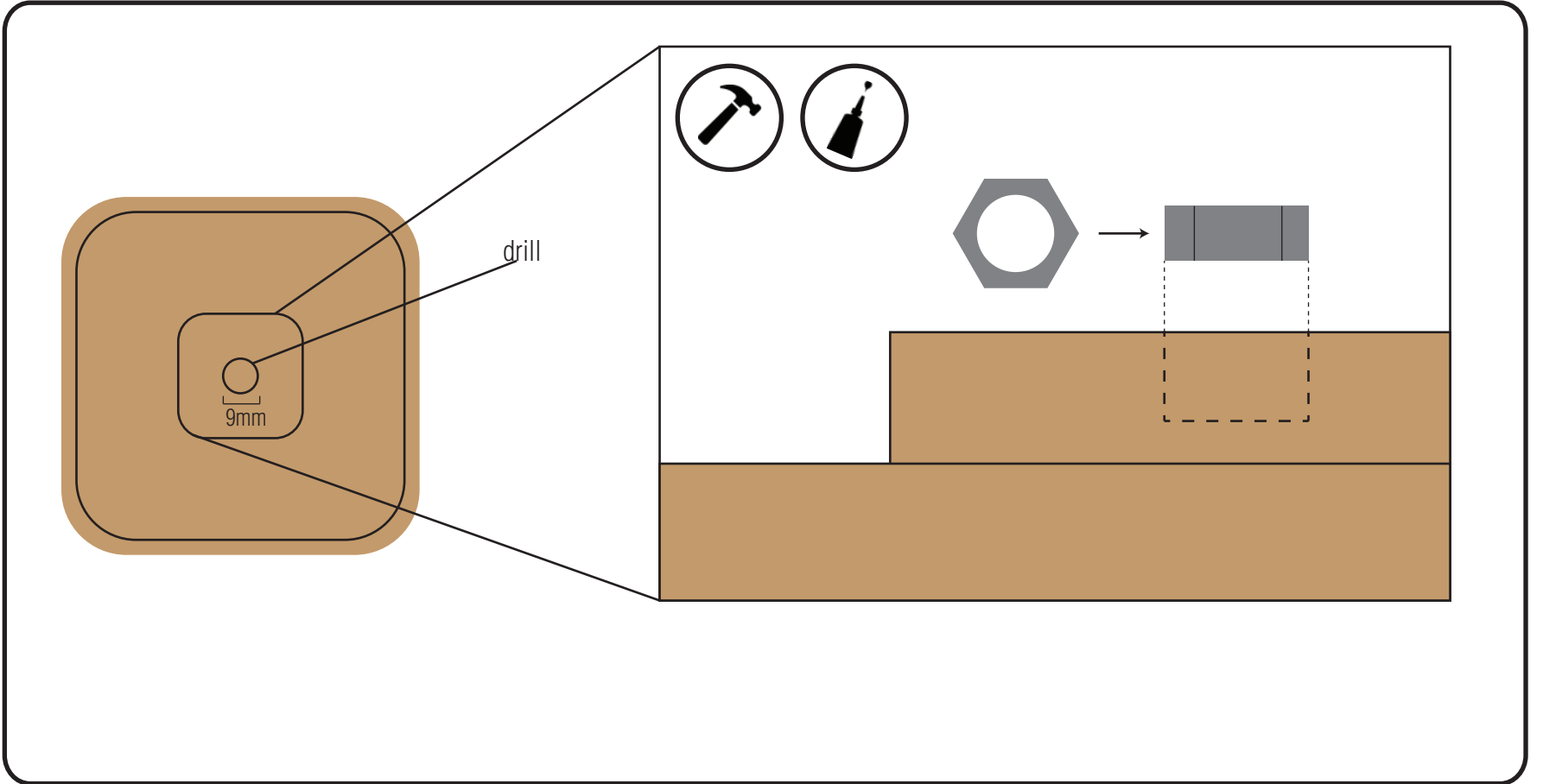

11

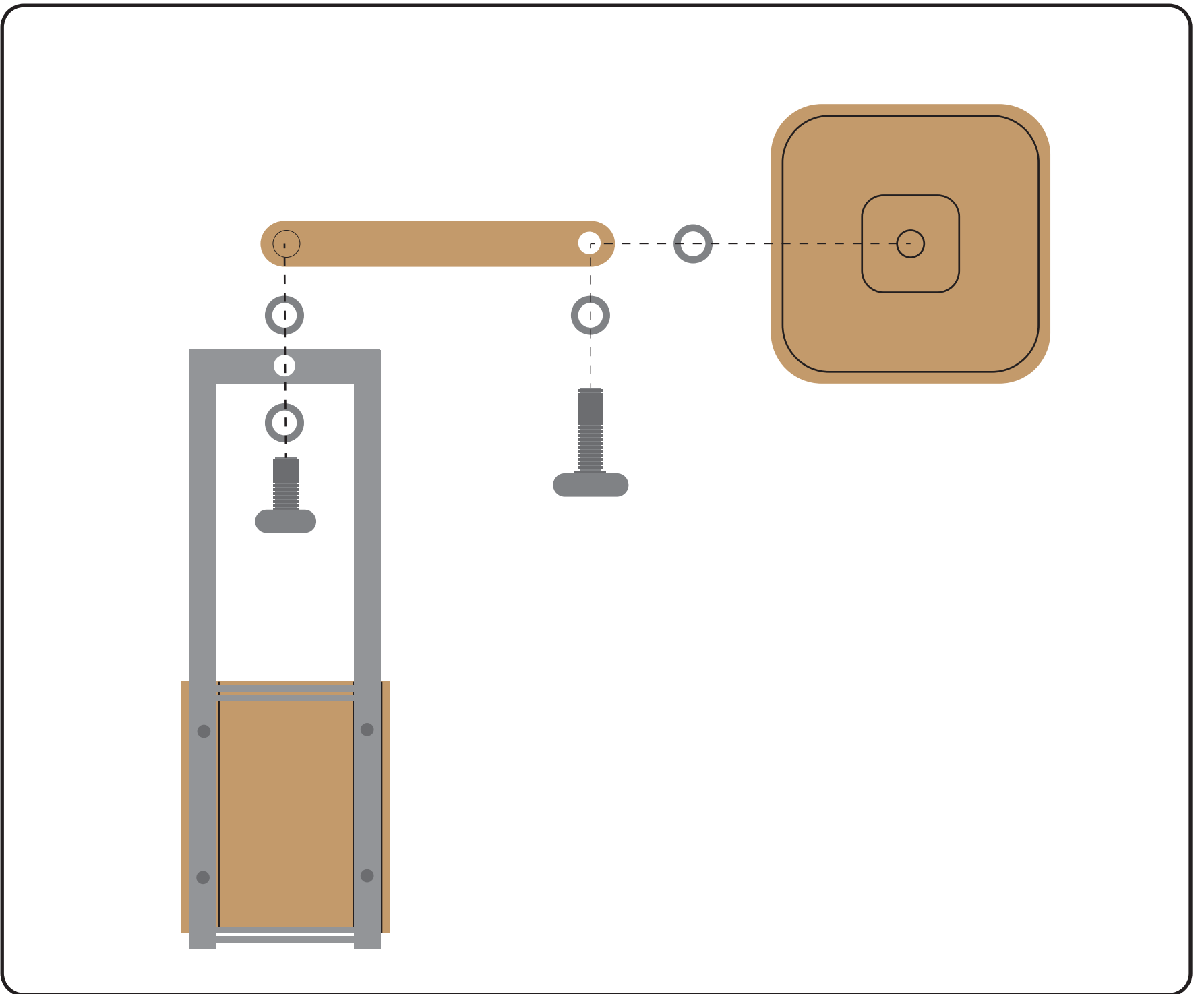

12

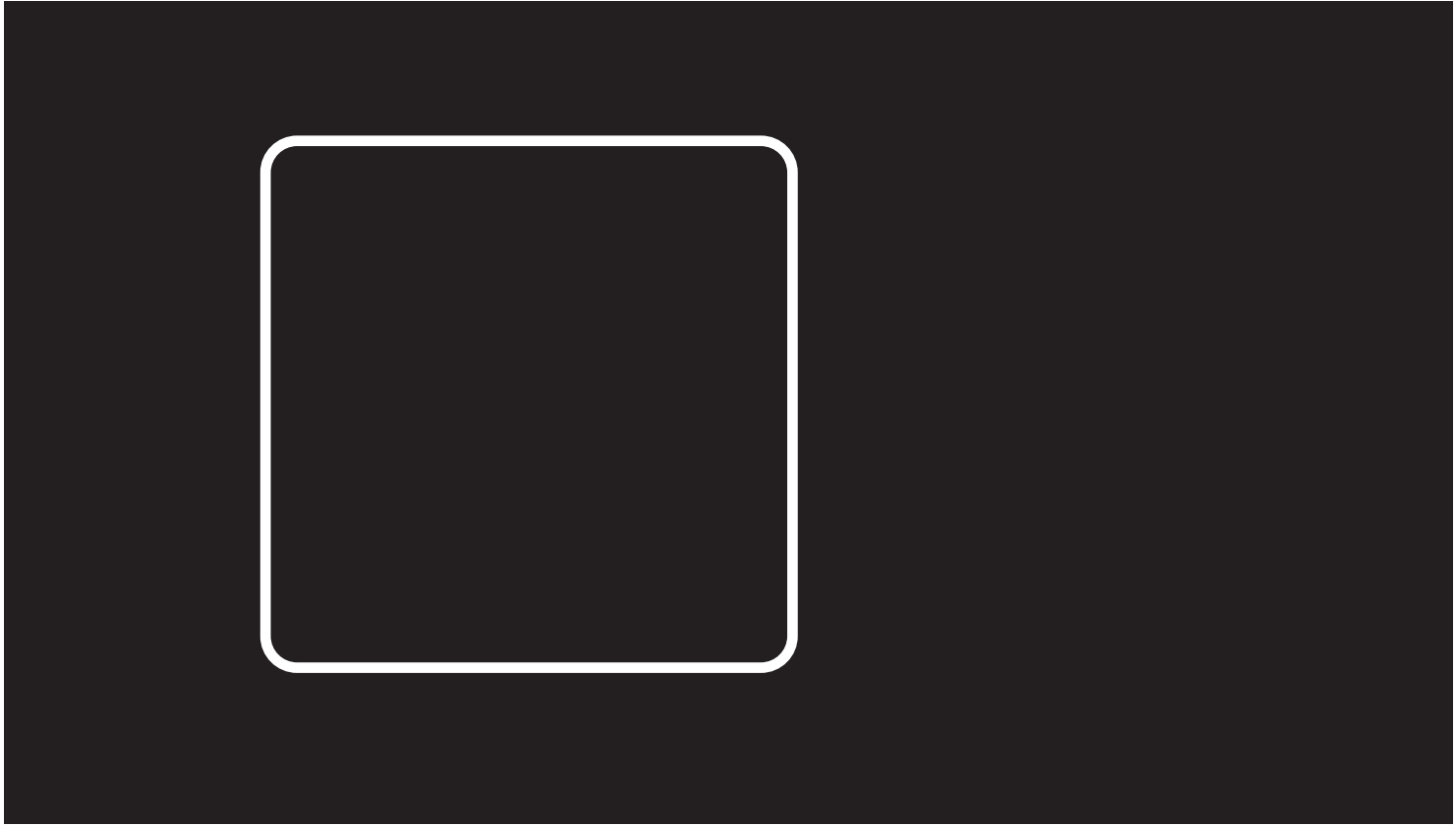

print out the template and cut the antislip surface.

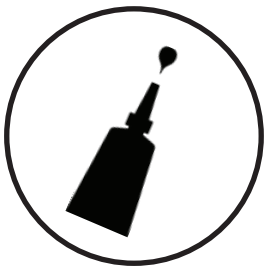

13

