

NOTES:

1. MATERIAL PROVIDED BY ISAAC
2. DEBUR ALL SHARP EDGES AND CORNERS

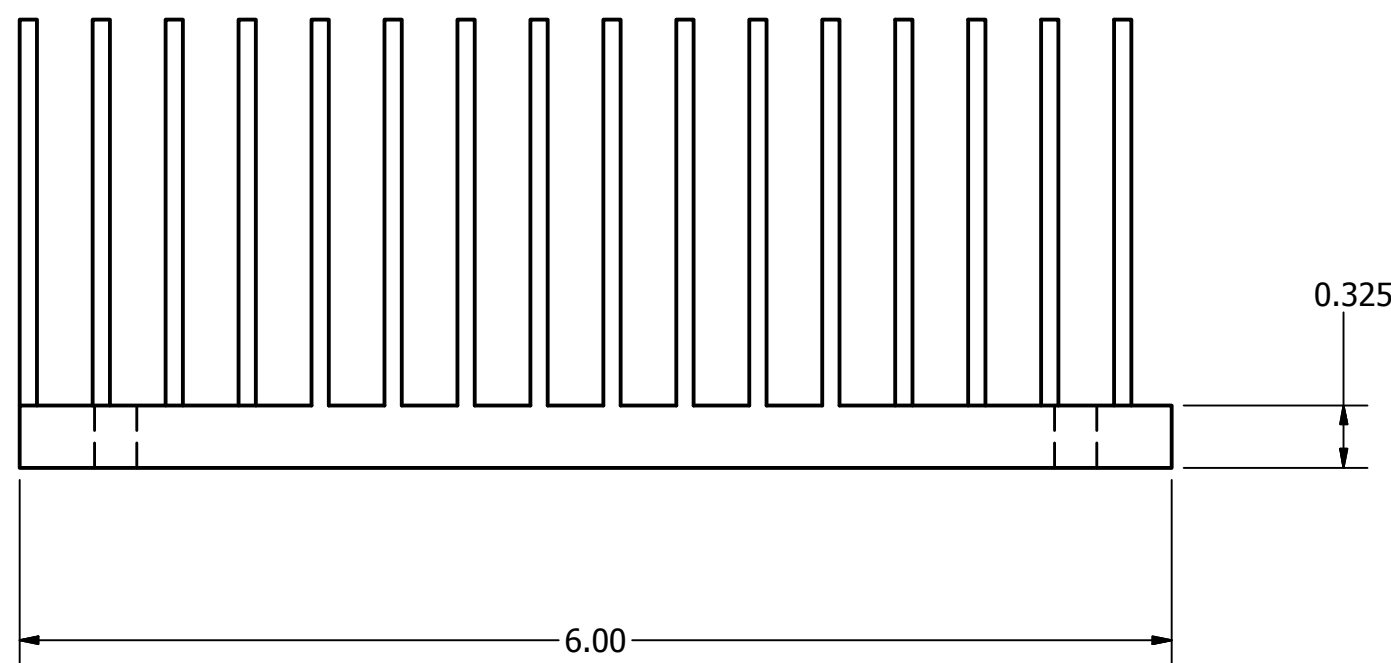
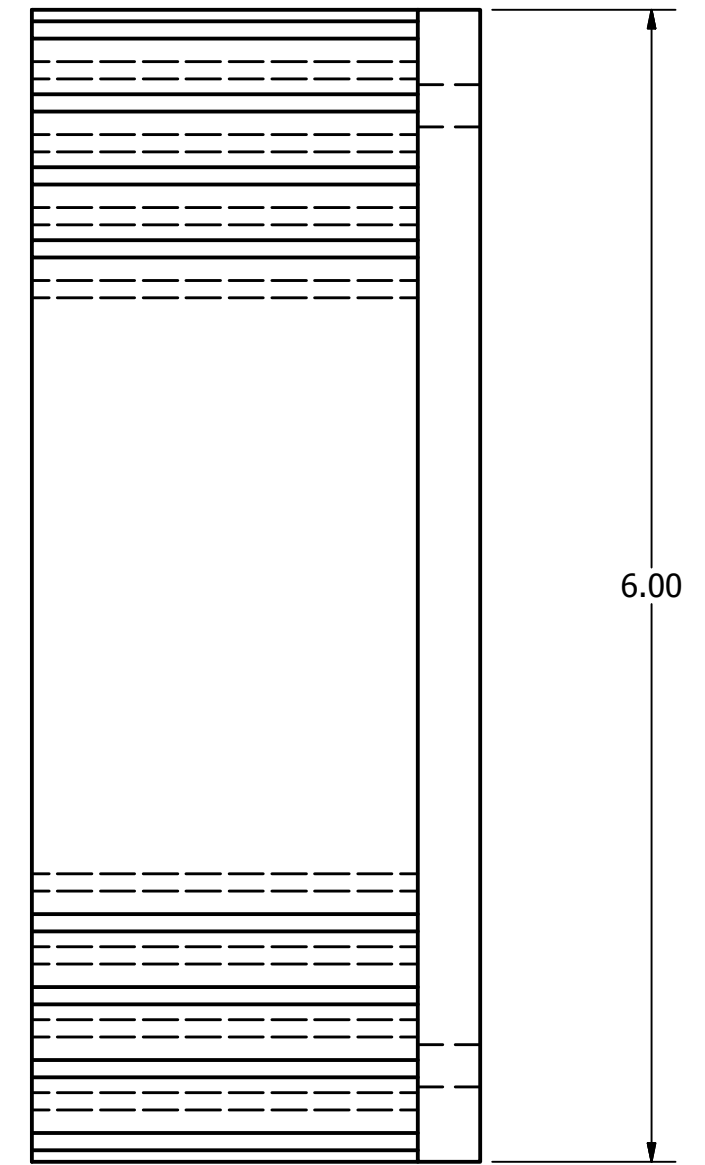
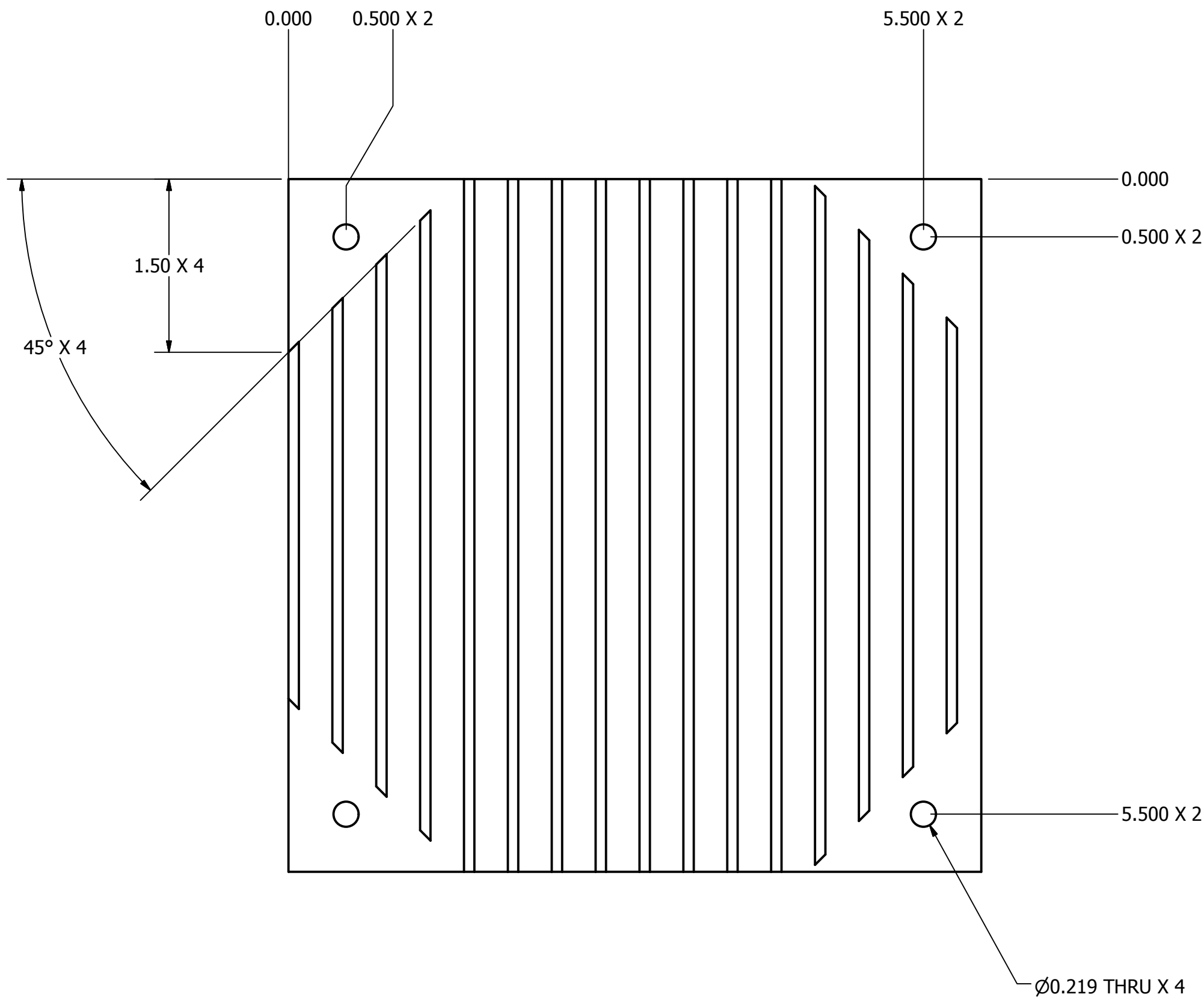

DRAWN ISAAC	10/5/2006	TITLE		
	TOLERANCE: X: ± .015 XX: ± .010 XXX: ± .005 ENGLISH	HEAT SINK BACKUP		
MATERIAL SEE NOTES		SIZE C	DWG NO hs_backup	REV A
FINISH BLACK ANODIZE		SCALE	SHEET 1 OF 2	