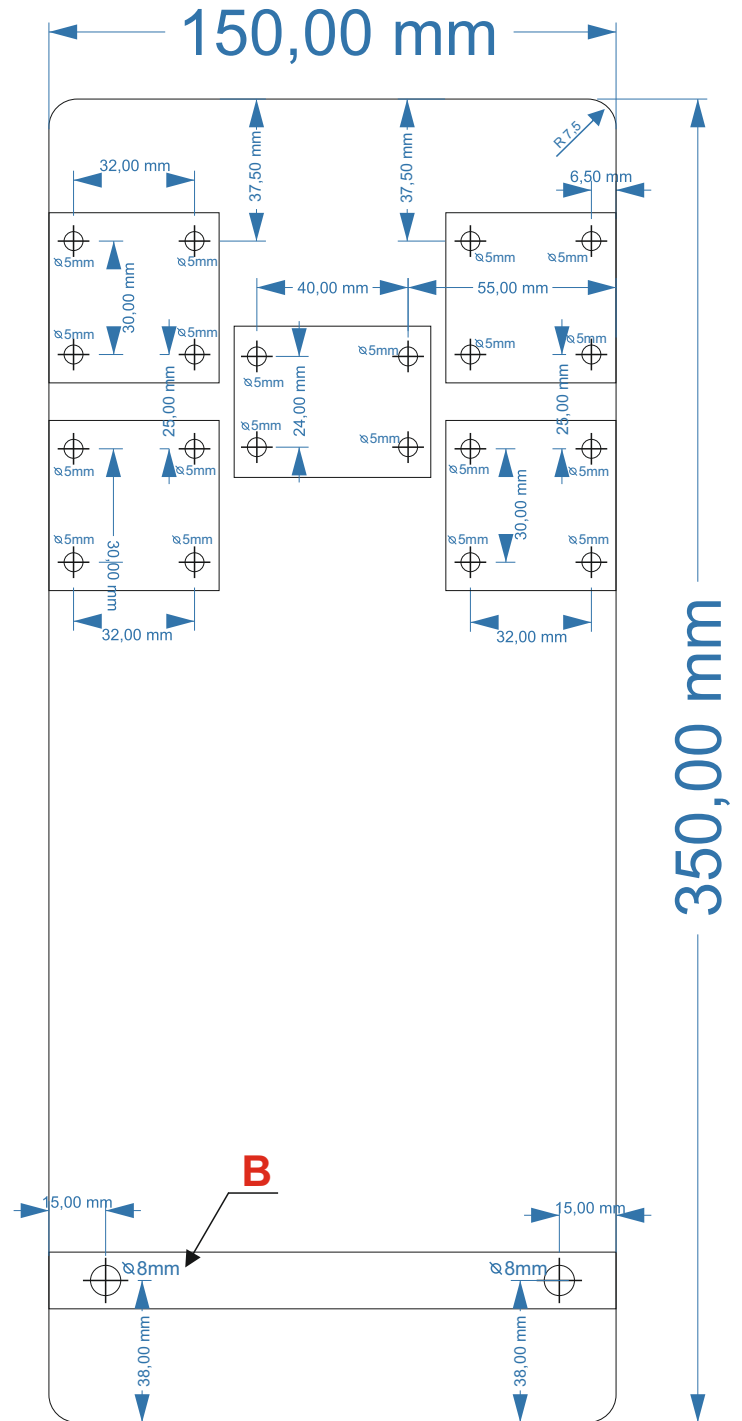
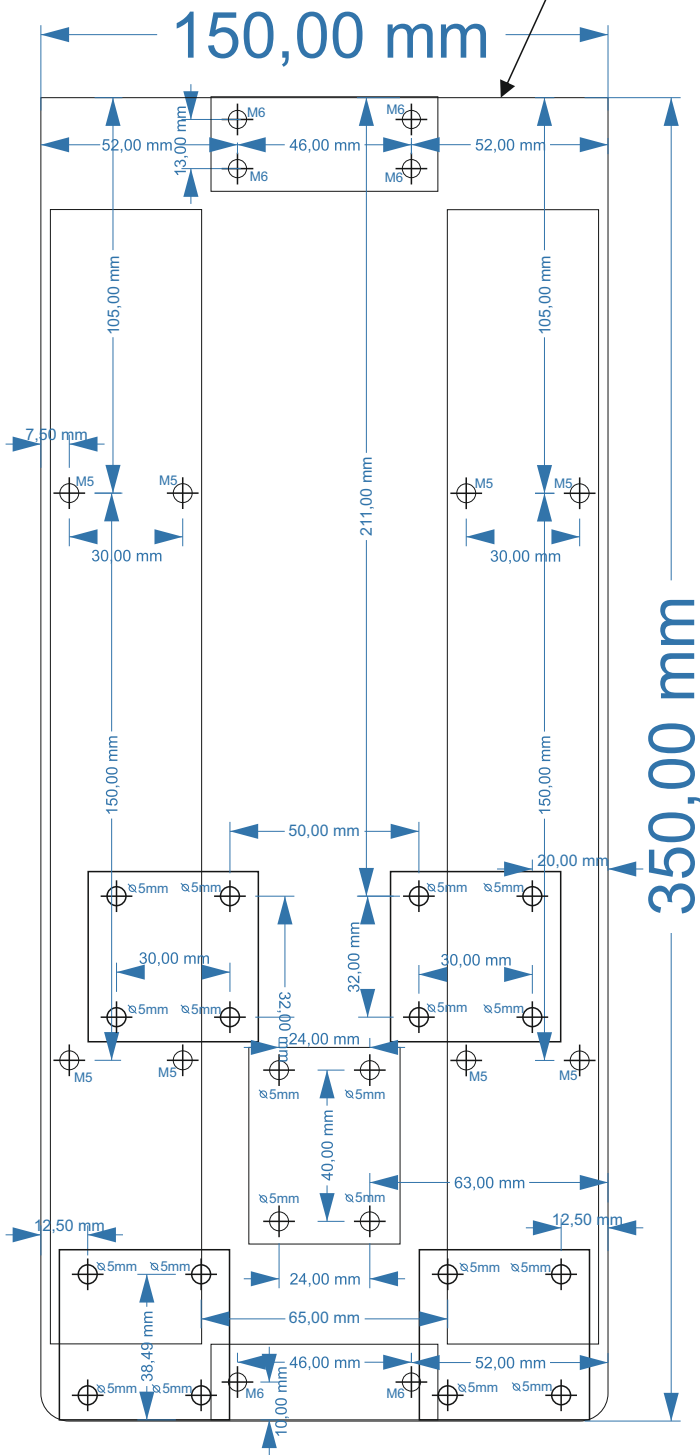

**A****B****Note:**

material thickness: 15mm

M5 (metric thread) / drill hole 4mm

**FRONT PART****Material:** ALU EN AW 6082 T6**Drawn:** Martin Dvoršćák**Date:** 3/2016**SHEET:** 1/2

SCALE 1:1

A)

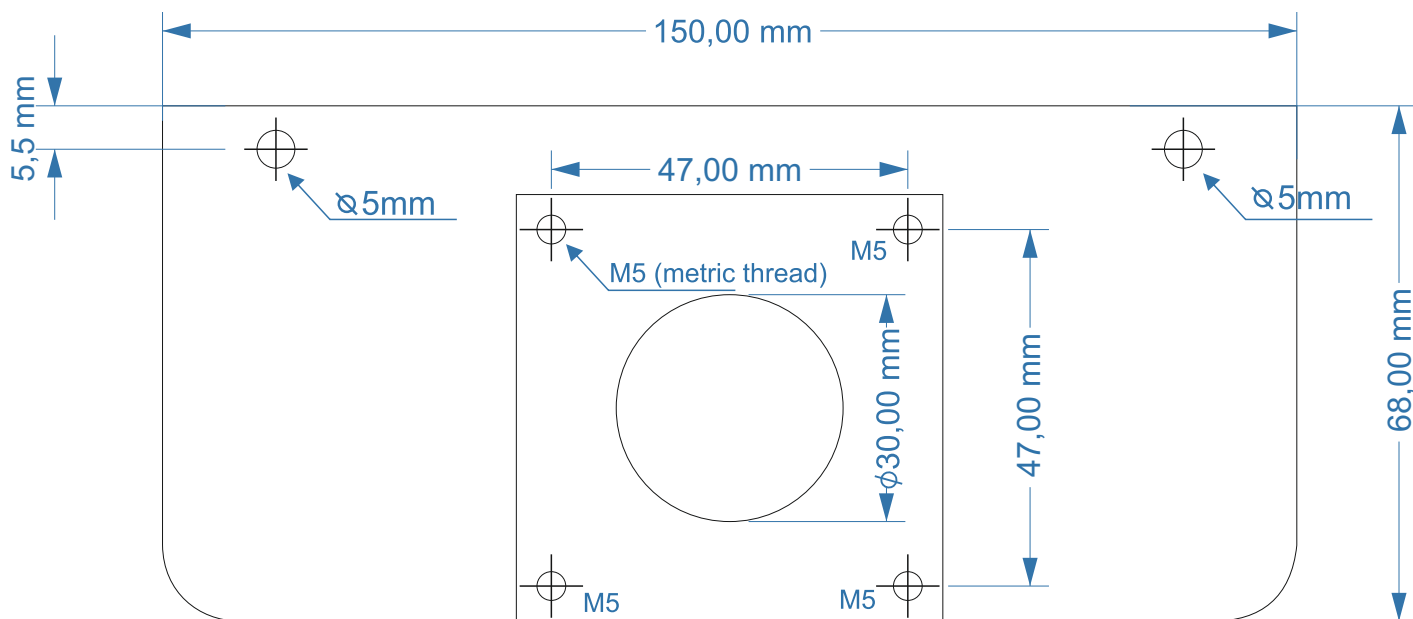

SCALE 1:1

B)

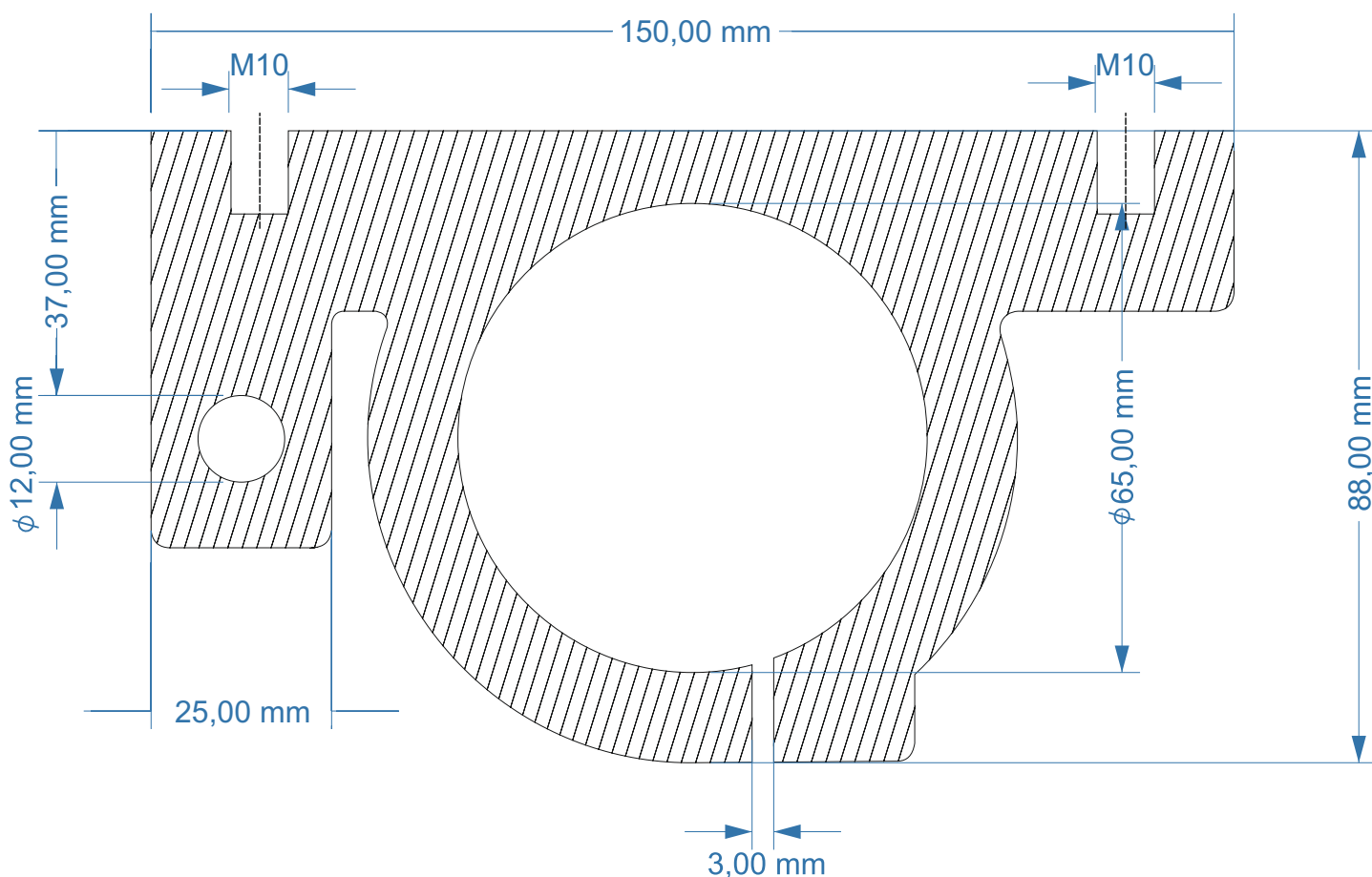

**Note:**

material thickness: 15mm

M5 (metric thread) / drill hole 4mm

M10 (metric thread) / drill hole 8mm

**FRONT PART**

**Material:** ALU EN AW 6082 T6

**Drawn:** Martin Dvoršćák

**Date:** 3/2016

**SHEET:** 2/2