



Model 5303 Installation Guide

This product is intended for installation by a professional installer only! Attempts to install this product by a person other than a trained professional may result in severe damage to a vehicle's electrical system and components.

Directed[®]
E L E C T R O N I C S

© 2008 Directed Electronics, Vista, CA
N5303L 2008-07

Bitwriter®, Code Hopping™, Doubleguard®, ESP2™, Fail-Safe®, Ghost Switch™, Learn Routine™, Nite-Lite®, Nuisance Prevention® Circuitry, Revenger®, Silent Mode™, Soft Chirp®, Stinger®, Valet®, Vehicle Recovery System®, VRS®, and Warn Away® are all Trademarks or Registered Trademarks of Directed Electronics.



The Bitwriter® (p/n 998U) requires chip version 2.5 or newer to program this unit.

Bitwriters with date code of 6A or older require an IC upgrade (p/n 998M). Some Bitwriters with a date code of 6B do not require the IC upgrade. Refer to Tech Tip # 1112 for more information. Bitwriter 2 compatible.



Contents

Warning! Safety first	5
Installation points to remember.....	7
Virtual tach	7
D2D.....	7
Before beginning the installation.....	8
After the installation	8
Component locations and finding wires	9
Valet/program switch.....	9
Status LED.....	10
Making your wiring connections	11
Primary harness (H1), 12-pin connector.....	12
Auxiliary harness (H2), 6-pin connector.....	12
Door lock harness, 3-pin connector	12
Remote start ribbon harness, wiring diagram	13
Heavy gauge relay satellite wiring diagram.....	13
Remote start harness, (H3) 5-pin connector	13
Horn, channel 6 (H4), 2-pin connector	14
Wire connection guides.....	14
Primary harness (H1), 12-pin connector.....	14
Auxiliary harness (H2), 6-pin connector.....	20
Remote start, (H3) secondary harness	25
Horn, (H4) Aux 3 harness.....	27
Neutral safety switch interface	28
Testing the neutral safety switch	28
Plug-in LED and valet/program switch.....	29
D2D programmer interface - 4-pin red plug.....	29
Shock sensor harness, 4-pin connector.....	30
Tachometer settings	31
Virtual tach	31
Tach learning	32
Programming jumpers.....	33
Tach threshold On/Off	33
Light flash (+) / (-) polarity	33
Transmitter/receiver Learn Routine™.....	34
Transmitter configurations.....	37
Standard configuration.....	37
Multi-level security arming	38
System features learn routine	39
Feature menus	41
Menu 1 - Basic	41
Menu 2 - Advanced	42
Menu 3 - Remote start	43

Feature descriptions.....	44
Menu 1 - Basic	44
Menu 2 - Advanced	47
Menu 3 - Remote start	50
NPC, Valet Mode, Rear defogger, Timer Mode.....	52
Table of zones	53
Shutdown diagnostics.....	54
Safety check.....	55
Troubleshooting	56
Alarm.....	56
Remote start	57
Wiring quick reference guide	59
Relay satellite wiring quick reference guide	60

➤ Primary harness (H1), 12-pin connector

H1/1	RED/WHITE	(-) 200mA TRUNK RELEASE OUTPUT
H1/2	RED	(+) CONSTANT POWER INPUT
H1/3	BROWN	(+) SIREN OUTPUT
H1/4	EMPTY	NOT USED
H1/5	BLACK	(-) CHASSIS GROUND INPUT
H1/6	VIOLET	(+) DOOR TRIGGER INPUT, ZONE 3
H1/7	BLUE	(-) MULTIPLEXED INPUT, ZONE 4
H1/8	GREEN	(-) DOOR TRIGGER INPUT, ZONE 3
H1/9	BLACK/WHITE	(-) 200mA DOMELIGHT SUPERVISION OUTPUT
H1/10	WHITE/BLUE	(-) REMOTE START ACTIVATION INPUT
H1/11	WHITE	(+)/(-) SELECTABLE LIGHT FLASH OUTPUT
H1/12	ORANGE	(-) 500mA ARMED OUTPUT

➤ Auxiliary harness (H2), 6-pin connector

H2/1	LIGHT BLUE	(-) SECOND UNLOCK OUTPUT
H2/2	WHITE/BLACK	(-) AUX 2 OUTPUT
H2/3	VIOLET/BLACK	(-) AUX 1 OUTPUT
H2/4	GREEN/WHITE	(-) FACTORY ALARM REARM
H2/5	GRAY/BLACK	(-) WAIT-TO-START INPUT
H2/6	LIGHT GREEN/ BLACK	(-) FACTORY ALARM DISARM

➤ Door lock harness, 3-pin connector

1	LIGHT BLUE	(-) UNLOCK OUTPUT (+) LOCK
2	EMPTY	NOT USED
3	GREEN	(-) LOCK (+) UNLOCK OUTPUT

➤ Remote start ribbon harness, wiring diagram

1	PINK/WHITE	(-) 200mA PROGRAMMABLE IGN2/ACC2 RELAY TURN ON
2	YELLOW	(+) IGNITION INPUT TO ALARM
3	PINK	(-) 200mA IGNITION RELAY TURN ON
4	ORANGE	(-) 200mA ACCESSORY RELAY TURN ON
5	PURPLE	(-) 200mA STARTER RELAY TURN ON
6	ORANGE/BLACK	(-) ANTIGRIND/GROUND WHEN ARMED OUTPUT
7	BLUE	(-) 200 mA STATUS OUTPUT

The ribbon harness connects to the relay satellite

➤ Heavy gauge relay satellite wiring diagram

H/1	PURPLE	STARTER OUTPUT TO STARTER (STARTER SIDE)
H/2	GREEN	STARTER INPUT FROM IGNITION (KEY SIDE)
H/3	RED	(+) HIGH CURRENT 12V INPUT
H/4	ORANGE	OUTPUT TO ACCESSORY CIRCUIT
H/5	PINK	OUTPUT TO PRIMARY IGNITION CIRCUIT
H/6	RED	(+) (30A) HIGH CURRENT 12V INPUT
H/7	PINK/WHITE	OUTPUT TO SECOND IGNITION CIRCUIT
H/8	RED/WHITE	(+) (30A) HIGH CURRENT 12V INPUT

➤ Remote start harness, (H3) 5-pin connector

H3/1	BLACK/WHITE	(-) NEUTRAL SAFETY SWITCH INPUT
H3/2	VIOLET/WHITE	TACHOMETER INPUT WIRE
H3/3	BROWN	(+) BRAKE SHUTDOWN INPUT WIRE
H3/4	GRAY	(-) HOOD PINSWITCH INPUT, ZONE 1
H3/5	BLUE/WHITE	(-) 200 mA 2ND STATUS/REAR DEFOGGER - Latched Pulsed

➤ Horn, channel 6 (H4), 2-pin connector

H4/1	ORANGE/BLACK	(-) AUX 3 OUTPUT
H4/2	BROWN	(-) 200 mA HORN

Wire connection guides

➤ Primary harness (H1), 12-pin connector

H1/1	RED/WHITE	(-) 200mA TRUNK RELEASE, 200 mA (-) output
------	-----------	--

When the system receives the code controlling trunk release output for longer than 1.5 seconds, the red/white wire will supply output as long as the transmission continues. This is typically used to operate a trunk/hatch release or other relay-driven function.

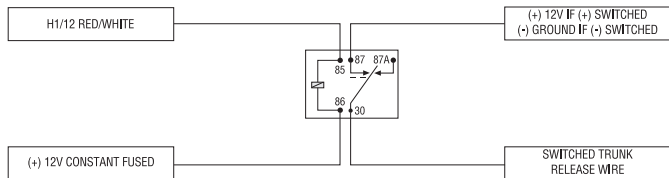

Warning! Never use this wire to drive anything but a relay or a low-current input, supplied output is only 200mA. Connecting directly to a solenoid, motor, or other high-current device will cause the module to fail.

H1/2**RED****(+) 12v CONSTANT POWER INPUT**

Before connecting this wire, remove the supplied fuse. Connect to the battery positive terminal or the constant 12V supply to the ignition switch.

Note: Always use a fuse within 12 inches of the point you obtain (+) 12V. Do not use the 15A fuse in the harness for this purpose. This fuse protects the module.

H1/3**BROWN****(+) SIREN OUTPUT**

Connect this to the red wire of the siren. Connect the black wire of the siren to (-) chassis ground, preferably at the same point you connected the control module's black ground wire. See Features Description section for horn output.

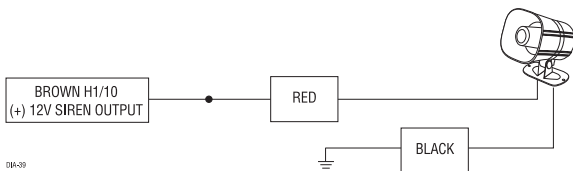

H1/5**BLACK****(-) CHASSIS GROUND**

Remove any paint and connect this wire to bare metal, preferably with a factory bolt rather than your own screw. (Screws tend to either strip or loosen with time) We recommend grounding all your components including the siren to the same point in the vehicle.

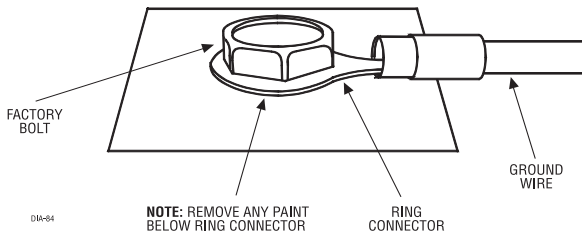
**H1/6****VIOLET****(+) DOOR TRIGGER INPUT, ZONE 3**

This wire is used in vehicles that have a positive (+) switched dome light circuit. Connect the violet wire to a wire that shows (+) 12V when any door is opened, and ground when the door is closed. This wire reports Zone 3.

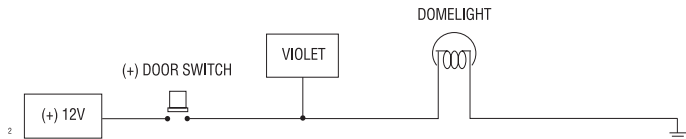

H1/7**BLUE****(-) MULTIPLEX INPUT, ZONE 4**

Inputs shorter than 0.8 seconds will trigger the Warn Away response, while inputs longer than 0.8 seconds will trigger the full alarm sequence. If installing an optional Directed Electronics dual stage sensor, connect both the blue and the green wires of the optional sensor to this input. This wire will report Zone 4.

H1/8**GREEN****(-) DOOR TRIGGER INPUT, ZONE 3**

Most vehicles use negative door trigger circuits. Connect the green wire to a wire which shows ground when any door is opened. In vehicles with factory delays on the dome light circuit, there is usually a wire that is unaffected by the delay circuitry. This wire reports Zone 3.

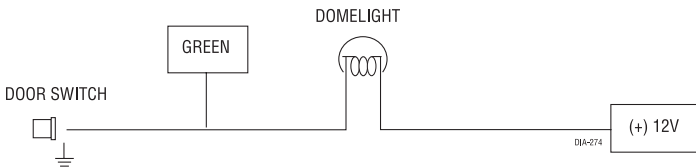

H1/9

BLACK/WHITE

(-) 200mA DOME LIGHT OUTPUT SUPERVISION OUTPUT

Connect this wire to the optional dome light supervision relay as shown below: Important! This output is only intended to drive a relay. It cannot be connected directly to the dome light circuit, as the output cannot support the current draw of one or more light bulbs.

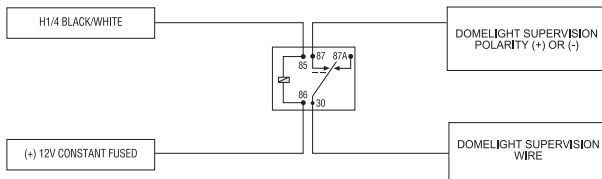

H1/10

WHITE/BLUE

REMOTE START (-) ACTIVATION INPUT

This input comes from the factory set to 1 activation pulse. This means that it is necessary to have a two consecutive on ground pulse on the white/blue wire for the remote start to activate or to deactivate. The same holds true for the remote control activation it is necessary to press the  button once for the remote start to activate or deactivate.

Note: The number of activation inputs can be programmed to 1 or 2 pulses with an optional momentary switch. This setting affects both the input wire and the remote control when operating the remote starter.

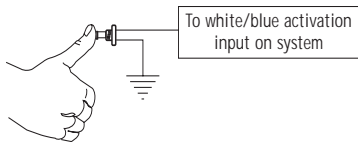

H1/11

WHITE

(+/-) SELECTABLE LIGHT FLASH OUTPUT

This wire is connected to the (+) parking light wire in the vehicle. If the light flash polarity jumper under the sliding door is moved to the opposite position (See Internal Programming Jumper section of this guide) this wire supplies a (-) 200 mA output.

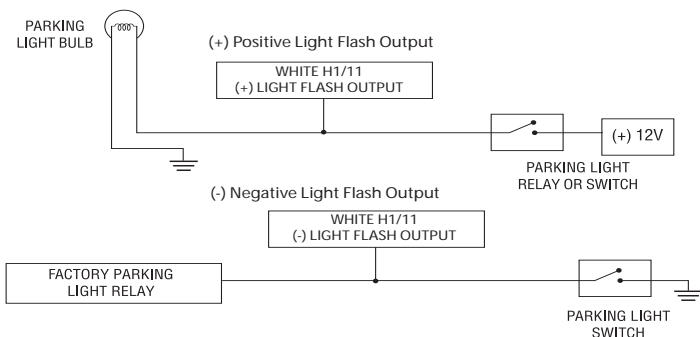

Note: For parking light circuits that draw 10-amps or more, the internal jumper must be switched to a (-) light flash output. (See Setting the light flash polarity section of this guide.) P/N 8617 or a standard automotive SPDT relay must be used on the H1/11 light flash output harness wire.

H1/12

ORANGE

(-) 500mA GROUND WHEN ARMED OUTPUT

This wire supplies a (-)500 mA ground as long as the system is armed. The output ceases as soon as the system is disarmed. The orange wire may be wired to an optional Directed Electronics 8618 starter kill relay.

➤ Auxiliary harness (H2), 6-pin connector

H2/1	LIGHT BLUE	200mA (-) 2nd UNLOCK OUTPUT
------	------------	-----------------------------

This wire produces a (-) 200mA output for progressive locks in which the driver door unlocks first and the remaining locks unlock with a second press of the unlock button.

H2/2	WHITE/BLACK	200mA PROGRAMMABLE (-) AUX 2 OUTPUT
------	-------------	-------------------------------------

This wire provides 200 mA programmable output whenever the transmitter button(s) controlling Aux 3 is pressed. This output can be programmed to provide the following types of outputs

- Validity: Output that sends a signal as long as the transmission is received.
- Latched: Output that sends a signal when the Aux channel button is pressed and continues until the same button is pressed.
- Latched, reset with ignition: Similar to the latched output, this type of output turns On the first time the Aux channel button is pressed, and turns Off the next time the same button is pressed. This type of output additionally stops and resets whenever the ignition is turned On and then Off.
- 30 seconds (60, 90) timed: The output sends a continuous signal for 30 seconds.

Note: Bitwriter® programs from 1 to 90 seconds.

	<p>Warning! Never use this wire to drive anything but a relay or a low-current input, supplied output is only 200mA. Connecting directly to a solenoid, motor, or other high-current device will cause the module to fail.</p>
---	---

H2/3**VIOLET/BLACK****(-) 200mA PROGRAMMABLE (-) AUX 1 OUTPUT**

This wire provides 200 mA programmable output whenever the transmitter buttons controlling Aux 1 channel is pressed.



Warning! Never use this wire to drive anything but a relay or a low-current input, supplied output is only 200mA. Connecting directly to a solenoid, motor, or other high-current device will cause the module to fail.

H2/4**GREEN/WHITE****FACTORY ALARM REARM OUTPUT**

This wire sends a negative pulse every time the remote start shuts down or when the doors are locked. This can be used to pulse the arm wire of the vehicle's factory anti-theft device. Use a relay to send a (-) or (+) pulse to the arm wire.

H2/5**GRAY/BLACK****(-) DIESEL WAIT TO START BULB INPUT**

Connect this wire to the wire in the vehicle that sends the signal to turn on the WAIT-TO-START bulb in the dashboard. In most diesels the wire is negative (ground turns on the bulb) and the GRAY/BLACK wire can be directly connected to the wire in the vehicle. If the vehicle uses a positive wire (12V to turn on the bulb) a relay must be used to change the polarity.

Note: A 1-amp diode must be installed in line on the factory wire between the wait-to-start indicator and the ECM. (See the following diagram for details).

(-) WAIT TO START WIRE

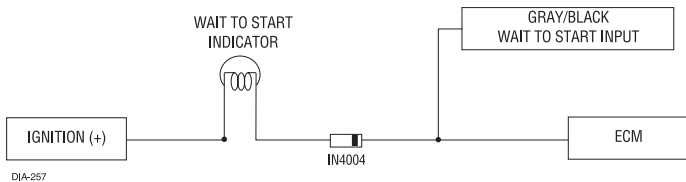

(+) WAIT-TO-START WIRE

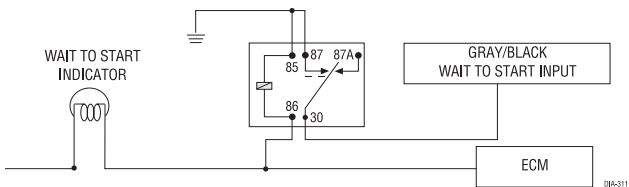

H2/6

LIGHT GREEN/BLACK

FACTORY DISARM OUTPUT

Relay for Negative (-) Disarm Wire

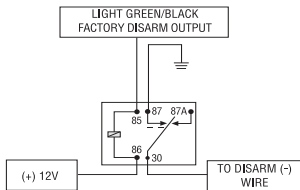

Relay for Positive (+) Disarm Wire

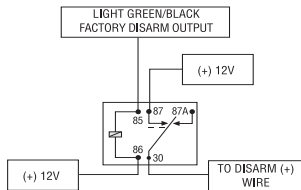

094-138

► Heavy Gauge, relay satellite

The heavy gauge wires coming from the large pin connector are used to energize the high current circuits in the vehicle. It is crucial to ensure that these connections are capable of handling the current demands. For this reason, Scotch-Locks, T-taps and other such connectors are strongly discouraged.

H/1

PURPLE

(+ STARTER OUTPUT

After cutting the starter wire connect the PURPLE wire to the end going to the starter motor.

H/2

GREEN

STARTER INPUT

After cutting the starter wire connect the GREEN wire to the end going to the key side of the ignition.

H/3	RED (2)	(+) 12V INPUT FOR HIGH CURRENT OUTPUTS
-----	---------	--

Remove the two 30-amp fuses prior to connecting these wires and do not replace them until the satellite has been plugged into the control module. These wires are the source of current for pink ignition, orange accessory, purple starter, and the coils for the relays in the relay pack. They must be connected to a high current source. Since the factory supplies (+)12V to the key switch that is used to operate the motor, it is recommended that these wires be connected there.

Note: If the factory supplies two separate (+) 12V feeds to the ignition switch, connect one RED wire of the satellite to each feed at the switch.

H/4	ORANGE	(+) ACCESSORY OUTPUT
-----	--------	----------------------

Connect this wire to the accessory wire in the vehicle which powers the climate control system.

H/5	PINK	(+) IGNITION OUTPUT
-----	------	---------------------

Connect this wire to the ignition wire in the vehicle.

H/6	PINK/WHITE	(+) SECOND IGNITION ACCESSORY OUTPUT
-----	------------	--------------------------------------

Connect this wire to the second ignition/accessory wire in the vehicle. (See menu feature 2-9.)

Note: For vehicles that do not have a second ignition/accessory wire, this connection is not required.

H/7	RED/WHITE	(+) 12V INPUT
-----	-----------	---------------

Connect this wire to a +12V source. It supplies voltage to the pink/white 2nd ignition/accessory output. If the vehicle does not have a 2nd ignition/accessory, then this wire does not need to be connected.

➤ Remote start, (H3) secondary harness

H3/1

BLACK/WHITE

NEUTRAL SAFETY SWITCH INPUT

Connect this wire to the provided toggle (override) switch as shown in figure A. Connect the other wire from the toggle switch to the park/neutral switch in the vehicle. This wire will test with ground with the gear selector either in PARK or NEUTRAL. This will prevent the vehicle from accidentally being started while in a drive gear. This input **MUST** rest at ground in order for the remote start system to operate. Connected properly the vehicle will only start while in PARK or NEUTRAL.

In some vehicles, the park/neutral position switch activates a factory starter lock out that will not allow the starter to operate in a drive gear. In these vehicles, connect this wire to the toggle switch as shown in figure B. Connect the other wire from the toggle switch to chassis ground.

Important: Always perform the Safety Check section of this installation guide to verify that the vehicle cannot be started in ANY drive gear and that the override switch is functioning properly.

Figure A

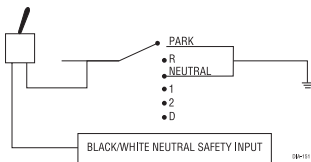

Figure B



H3/2

VIOLET/WHITE

TACHOMETER INPUT

This input provides the module with information about the engine's revolutions per minute (RPMs). It can be connected to the negative side of the coil in vehicles with conventional coils. In multi-coil and high energy ignition systems locating a proper signal may be more difficult. Once connected, you must teach the system the tach signal. (See the Internal Programming Jumpers section of this guide.)

H3/3

BROWN

(+ BRAKE SWITCH INPUT, ZONE 1)

This wire **MUST** be connected to the vehicle's brake light wire. This is the wire that shows (+) 12V when the brake pedal is depressed. The remote start will be disabled or shut down any time the brake pedal is depressed. This wire will also trigger the security system if the brake pedal is pressed while the system is armed and will report Zone 1.

H3/4

GRAY

(-) HOOD PIN SWITCH INPUT, ZONE 1

This wire **MUST** be connected to a hoodpin switch. This input will disable or shut down the remote start when the hood is opened. It will also trigger the security system if the hood is opened while the system is armed and report Zone 1.

H3/5

BLUE/WHITE

(-) STATUS OUTPUT

This wire supplies a 200mA output as soon as the module begins the remote start process. The H3/1 Blue/White wire can also be used to activate the defogger trigger (latched/pulsed), 10-seconds after the remote start engages. (See the Feature Descriptions section in this guide for details about programming this output.)

► Horn, (H4) Aux 3 harness

H4/1

ORANGE/BLACK

200 mA PROGRAMMABLE (-) AUX 3 OUTPUT

This wire provides a (-) 200mA output whenever the transmitter button(s) controlling Aux 3 is pressed. (see also the Feature Descriptions section and previous Aux 2 description)



Warning! Never use this wire to drive anything but a relay or a low-current input, supplied output is only 200mA. Connecting directly to a solenoid, motor, or other high-current device will cause the module to fail.

H4/2

BROWN

200mA (-) HORN OUTPUT

This wire provides a (-) 200mA output to the horn when programmed.



Warning! Never use this wire to drive anything but a relay or a low-current input, supplied output is only 200mA. Connecting directly to a solenoid, motor, or other high-current device will cause the module to fail.

Neutral safety switch interface

Some vehicles do not have an electrical neutral safety switch. Instead, the vehicle has a mechanical neutral safety switch that physically interrupts the starter wire and is used when the vehicle is in any drive gear. If the remote start is interfaced before this switch, it will provide protection from starting in gear. However, some vehicles combine the column shift mechanism and the mechanical neutral safety switch into one mechanical part.

Note: You must complete the remote start system installation before doing the following test. Ensure that the remote start system is functioning normally. This includes connecting to the brake as a shut-down.

► Testing the neutral safety switch

1. Make sure there is adequate clearance to the front and rear of the vehicle because it may move slightly.
2. Make sure the hood is closed and there are no remote start shut-downs active.
3. Set the emergency brake.
4. Turn the key to the "run" position, this will release the shifter.
5. Place the car in drive (D).
6. Place your foot directly over the brake pedal, but do not depress it. Be ready to step on the brake if the starter engages.
7. Activate the remote start system.
8. If the starter engages, immediately depress the brake to shut the remote start system down. If the starter does not engage, no additional safety system is required.

If the starter engages and the vehicle is a General Motors product or Dodge Dakota pickup, you can find an alternative shut-down method to prevent the starter from engaging. Refer to www.directechs.com for Document 1008 under the Resource tab. If the vehicle is not a General Motors product or a Dodge Dakota pickup, please call Directed Electronics Technical Support for an alternative shut-down method.

Do not return the vehicle to the customer until this feature is properly installed!

Plug-in LED and valet/program switch

These plug into the module. The Status LED plugs into the small two-pin socket, while the Valet /Program Switch should be plugged into the larger blue two-pin connector. The Status LED fits into a 9/32-inch hole.

Status LED

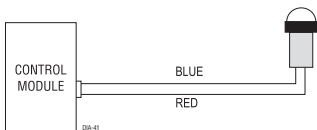

Valet/Program Switch

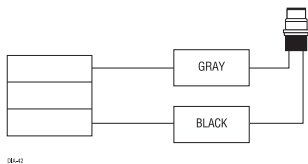

D2D programmer interface - 4-pin red plug

The 4-pin red port is for interfacing with an XK module through D2D, or you can use it for programming with the Bitwriter. If the XK module is unplugged so the port can be used for Bitwriter programming, you must reprogram the XK module when plugging it back into the 4-pin red port.



When the learn routines have previously been programmed using the Bitwriter, they may have been locked. Before proceeding with reprogramming the learn routines, they must be unlocked with the Bitwriter - this cannot be done manually with the Valet switch.

Note: Bitwriters require software v2.5. Bitwriters with date code of 6A or older require an IC upgrade (p/n 998M). Some bitwriters with a date code of 6B do not require the IC upgrade, refer to Tech Tip # 1112 for more information. Bitwriter 2 compatible.

Shock sensor harness, 4-pin connector

H	GREEN	(-) MULTIPLEX INPUT, ZONE 2
----------	-------	-----------------------------

Inputs shorter than 0.8 seconds will trigger the Warn Away® response, while inputs longer than 0.8 seconds will trigger full alarm sequence and report Zone Two. If installing an optional Directed Electronics dual stage sensor, connect to the green wire as shown below. The diagram below eliminates the need for diodes to isolate the sensors.

Diagram for adding optional Directed Electronics dual stage sensor to green wire (Zone 2):

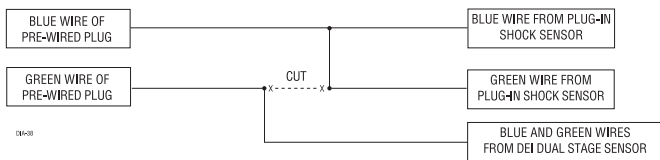

H	BLUE	(-) MULTIPLEX INPUT, ZONE 2
----------	------	-----------------------------

Inputs shorter than 0.8 seconds will trigger the Warn Away® response, while inputs longer than 0.8 seconds will trigger full alarm sequence and will also report Zone Two.

H	RED/BLACK	RED: is (+) 12V CONSTANT, BLACK is (-) GROUND
----------	-----------	---

Do not use these for anything besides the plug-in shock sensor.

Tachometer settings

► Virtual tach

To program Virtual Tach:

1. After the install is complete, remote start the car.
2. If the car does not start on the first attempt, let the remote start attempt again.
3. Once the car starts, let it run until the parking lights come on.
4. When the parking lights come on, shut off the remote start with the remote - that's it! Virtual Tach is programmed.

To reset Virtual Tach, go into the remote programming grid and choose option #4. Virtual Tach **cannot** be reset with the Bitwriter.

Virtual Tach handles disengaging the starter motor during remote starting – it does not address over-rev. If the customer wants to have the over-rev protection capability, now listed as optional in the owner's guide, the tach wire must be connected. This may involve more installation shop charges than initially quoted.

Important: If the Virtual Tach mode over cranks or doesn't crank the vehicle long enough to start and run the car, use the Bitwriter to add or subtract the starter output time. You can adjust the output time in increments of 50mSec of the learned time using the Bitwriter.

► Tach learning

To learn the tach signal:



1. Start the vehicle with the key.



2. Within 5 seconds, press and hold the Valet/Program switch.







3. After 3 seconds the LED will light constant when the tach signal is learned.



4. Release the Valet/Program switch.

Programming jumpers

- TACH THRESHOLD OFF (DEFAULT) 
- TACH THRESHOLD ON 
- (-) LIGHT FLASH OUTPUT 
- (+) LIGHT FLASH OUTPUT (DEFAULT) 



TO CHANGE
JUMPER
SETTINGS

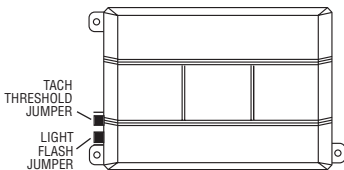

► Tach threshold On/Off

In most cases, this jumper can be left in the Off position. Some new vehicles use less than 12 volts in their ignition systems. The unit may have trouble learning the tach signal in these vehicles. Changing the jumper to the On setting changes the trigger threshold of the digital tach circuit so that it will work with these type vehicles.

► Light flash (+) / (-) polarity

The internal fuse is used to determine the light flash output. In the (+) position, the onboard relay will output (+)12V on the WHITE wire, H1/11. In the (-) position, the on-board relay will supply a (-) output. When wiring into a multiplex circuit, you can replace the fuse with a resistor (paying attention to the polarity setting). (Refer to diagram on p.24, H1/4 White/ Brown wire description).

Note: For parking light circuits that draw 10 amps or more, the internal jumper must be switched to a (-) light flash output. P/N 8617 or a standard automotive SPDT relay must be used on the H1/11 light flash output harness wire.

Transmitter/receiver Learn Routine™

The system comes with transmitters that have been taught to the receiver. The receiver can store up to 4 different transmitter codes in memory. Use the following learn routine to add transmitters to the system.

The learn routine may be locked if previously programmed using the Bitwriter®. If the siren generates one long chirp when attempting to program the unit, the learn routine is locked and must be unlocked using the Bitwriter® before proceeding.

The Valet/Program switch, plugged into the blue port, is used for programming. There is a basic sequence to remember whenever programming this unit: Door, Key, Choose, Transmit and Release.



1. Open a door. (The GREEN wire, H1/8, or the VIOLET, H1/6 must be connected.)



2. Insert the key. Turn the ignition to the ON position. The heavy gauge pink wire must be connected.



3. Choose. Within 10 seconds, press and release the Program switch corresponding to the number of the desired function step listed in the following table.

Once you have selected the function step, press the switch once more and hold it. The LED flashes and the horn honks to confirm the selected functional step. Do not release the Program switch.

Step	Function
1	Auto Learn Standard Configuration (default) The auto learn configuration will automatically setup the remote button configuration. Note: Due to the Supercode protocol, you cannot change the configuration.
2	Delete remotes: This feature will erase all remotes from the memory of the system. This is useful in cases when a customer's remote is lost or stolen. Note: Does not reset the programmed features of the system or reset the Virtual Tach setting.
3	Reset Features: This resets all the features of the system to the factory default settings. Note: Does not delete the remotes from the system or reset the Virtual Tach setting.
4	Virtual Tach Reset: Deletes all previously learned values for Virtual Tach, and on the next remote start sequence the unit will begin virtual tach initialization. Note: The "Zap" feature on the Bitwriter does not reset the Virtual tach setting.



4. Transmit. While holding the Valet/Program switch, press the  button on the remote control. The horn honks to confirm that the code has been successfully programmed. It is not possible to teach a remote control button to the system more than once.



5. Release. Once the code is learned, the Valet/Program switch can be released.

You can advance from programming one channel to another by releasing the Valet/Program switch and tapping it to advance channels and then holding it.

For instance: You have programmed Step 1 and you want to program Step 2. Release the Valet/Program switch. Press it one time and release it to advance from Step 1 to Step 2. Now, press and hold the Valet/Program switch. The LED flashes two times and the siren chirps. As before, do not release it.

If you want to program Step 3 after programming Step 1, release the Valet/Program switch, press it twice and release it to advance to Step 3. Then press it once more and hold it. The siren chirps three times and the LED flashes three times to confirm it is ready to receive the code from the transmitter.













Learn Routine is exited if:

- Door is closed.
- The ignition is turned off
- The program switch is pressed too many times
- More than 15 seconds elapses between steps

Transmitter configurations

The transmitters are programmed with the standard configuration by using the Auto Learn functions in the Transmitter/Receiver Learn Routine. For more information about the remote control functions, see the Owners Guide.

► Standard configuration

		operates	Arm / Lock Panic ON/ Panic OFF
		operates	Disarm/Unlock Panic OFF
		operates	Remote Start
AUX		operates	Trunk Release
 and 		operates	Timer Mode
AUX and 		operates	Short Run/Turbo timer
 and AUX		operates	Aux 1
 and AUX		operates	Aux 2
 and  and AUX		operates	Rear Defogger
 and 		operates	Aux 3

Multi-level security arming

Multi-Level Security Arming is a feature that allows the user to select which of the system's inputs or sensors will be active and which will be bypassed when the system is armed. (See Table of Zones section of this guide.) Multi-Level Security Arming can only be accessed from a standard configuration transmitter. Pressing the arm button of the standard configuration transmitter again within five seconds of arming the system will activate the Multi-Level Security feature. Each time the arm button is pressed again, a different security level is selected. The different levels of security are selected as follows:

Pressing  one time: The siren chirps once. The system is armed.

Pressing  a second time within five seconds: The siren chirps twice followed by a long chirp. Zone Two is now bypassed.

Pressing  a third time within five seconds: The siren chirps three times followed by a long chirp. Zone Four is now bypassed.

Pressing  a fourth time within five seconds: The siren chirps four times followed by a long chirp. Zones Two and Four are now bypassed.

Pressing  a fifth time within five seconds: The siren chirps five times followed by a long chirp. All input zones, except the ignition, are now bypassed.

System features learn routine

The System Features Learn Routine dictates how the unit operates. It is possible to access and change any of the feature settings using the Valet/program switch. However, this process can be simplified by using the Bitwriter®. Any of the settings can be changed and then assigned to one of four remote controls. This feature is called Owner Recognition. Each time that particular remote control is used to disarm the system, the assigned feature settings will be recalled. Owner Recognition is only possible when programming the unit via the Bitwriter®.



If programming with the Bitwriter®, the learn routine can be locked or unlocked. If the learn routine has previously been locked, it must be unlocked with Bitwriter® - this cannot be done manually with the Valet switch.



1. Open a door. (The GREEN wire, h1/8, or the VIOLET, H1/6 must be connected.)



2. Ignition. Turn the ignition on, and then off.





3. Select menu. Press and hold the Valet/Program switch. When the LED flashes once and the siren chirps Menu One has been selected. Continue to hold the switch until the LED flashes twice and the siren chirps twice Menu Two has now been selected. Release the switch after the Menu choice has been selected.



4. Choose. Within 10 seconds, press and release the Valet/Program switch the number of times corresponding to the feature number you want to program and then press and hold the switch. (See Feature Menus. After a second, the LED will flash to indicate which feature you have accessed. For example, in Menu Two, groups of eight flashes would indicate access to the activation pulse setting (Feature 2-8). The siren will also chirp eight times.



5. Transmit. The transmitter is used to select the desired setting. Pressing  changes the feature to the LED On setting (or flashes once for features with more than 2 settings). The siren honks once. Pressing  changes the setting to the LED OFF setting (or flashes two or more times for features with more than 2 settings).



6. Release, the Valet/program switch.

You can advance from feature to feature by pressing and releasing the Valet/Program switch the number of times necessary to get from the feature you just programmed to the feature you wish to access. For example, in Menu One, if you just programmed Feature 1-2 and you next want to program Feature 1-3 to off, release the Valet/Program switch. Press and release it once to advance from Feature 1-2 to Feature 1-3. Then press it once more and hold it. The LED will flash in groups of 3 and the siren chirps to confirm that you have accessed Feature 1-3.

The learn routine is exited when:

- The door is closed.
- The ignition is turned on.
- The Valet/Program switch is pressed too many times.
- More than 15 seconds elapses between programming steps.

Once long siren chirp indicates that the Learn routine has been exited.

Feature menus

The default settings are indicated in bold type. Features that have additional settings that can be programmed using the Bitwriter® are indicated with an asterisk (*) The number in parentheses indicates the number of times the LED flashes.

► Menu 1 - Basic

Menu Item	One-chirp setting	Two-chirp setting
1	Active Arming	Passive arming
2	Arm/disarm chirps on	Arm/disarm chirps Off
3	Ignition lock On	Ignition lock Off
4	Ignition unlock On	Ignition unlock Off
5	Active locking only	Passive locking
6	Panic with ignition On	No panic with ignition On
7	0.8 second door lock pulses (1)	3.5 (2), 0.4 (3) seconds
8	Forced passive arming on	Forced passive arming off
9	Automatic engine disable on	<i>Automatic engine disable off</i>
10	Armed When Driving (AWD) on	AWD Off
11	Code Hopping On	Code Hopping off
12	Horn Output Pulsed	Constant
13	Horn function Full Alarm Only (1)	Siren function - chirp length 20mS (2), 30mS (3), 40mS (4), 50mS (5)
14	Comfort Closure ON	Comfort Closure OFF (3), Comfort Closure (2)

► Menu 2 - Advanced

Menu Item	One-chirp setting	Two-chirp setting
1	30 second siren duration	60 second siren duration*
2	Nuisance Prevention Circuitry On	Nuisance Prevention Circuitry OFF
3	Progressive door trigger	Instant door trigger
4	Disarm from Valet, 1 pulse	Disarm from Valet, 2-5 pulses
5	Door trigger error chirp ON	Door trigger chirp OFF
6	Ignition controlled domelight On	Ignition controlled domelight OFF
7	Unlock output 1 pulse	Unlock output 2 pulses
8	Lock output 1 pulse	Lock output 2 pulses
9	Factory disarm with trunk release	Factory disarm with trunk release
10	FAD function with Unlock (1)	Before Unlock (2), Remote Start only (3)
11	FAD 1 pulse	2 pulses
12	Aux 1 validity (1)	Arm (2)/Disarm (3), Remote Start (4)
13	Aux 1 Linking None (1)	Siren function - chirp length 20mS (2), 30mS (3), 40mS (4), 50mS (5)
14	Aux 2 validity (1)	Latched (2), Latch reset with ignition (3), 30-sec. timed (4)
15	Aux 2 linking None (1)	Arm (2)/Disarm (3), Remote Start (4)
16	Aux 3 validity (1)	Latched (2), Latch reset with ignition (3), 30-sec. timed (4)
17	Aux 3 linking None (1)	Arm (2)/Disarm (3), Remote Start (4)

*Bitwiter™ can set 1 - 180 seconds

► Menu 3 - Remote start

Menu Item	One-chirp setting	Two-chirp setting
1	Engine checking: Virtual Tach	Voltage(2), OFF(3), Tachometer(4)
2	Remote start runtime: 12 mins	24 min, 60 min
3	Parking light output: Flashing	Constant
4	Cranking time: 0.6 sec	0.8, 1.0, 1.2, 1.4, 1.6, 1.8, 2.0, 4.0 second
5	Activation pulse 1	2
6	2nd Ignition/Acc output: Ignition	Accessory
7	Acc state during wait-to-start Off	On
8	2nd status output: Normal	Rear defogger: latch 10 min. rear defogger pulse
9	Anti grind: On	Off
10	Diesel timer: Wait-to-Start input	Timed 15 , 30 ,45 seconds*
11	Timer mode run time: 12 min	3, 6, 9, min
12	Timer mode: Timed starts	Temp starts
13	Short run (turbo): 1 min	3,5, 10 min

*Bitwriter™ can set 1 - 180 seconds.

Feature descriptions

The features of the system are described below. Features that have additional settings are selected only when programming with the Bitwriter® are indicated by the following icon: 

Default settings are in bold. The numbers in parentheses indicate the number of times the Status LED flashes.

► Menu 1 - Basic

1-1 Active/Passive Arming: When active arming, the system arms only when the transmitter is used. When set to passive, the system arms automatically 30 seconds after the last door is closed. To alert the consumer of passive arming, the siren chirps 20 seconds after the door is closed. This provides the consumer with an audible warning prior to the system actually arming. At the 30 second mark, the system arms, but the siren does not chirp.

1-2 Chirps On/Off: This feature controls the chirps that confirm the arming and disarming of the system.

1-3 Ignition Lock On/Off: When turned On, the doors lock 3 seconds after the ignition is turned Off.

1-4 Ignition unlock On/Off: When ON this feature unlocks the doors when the ignition is turned off

1-5 Active/Passive Locking: If passive arming is selected in Feature 1-1, then the system can be programmed to either lock the doors when passive arming occurs, or only lock the doors when the system is armed via the transmitter. Active locking means the system will not lock the doors when it passively arms. Passive locking means that the system will lock the doors when it passively arms.

Note: Remember, when passive arming is selected, the unit will chirp 20 seconds after the last door is closed. The system does not actually arm or lock the doors until 30 seconds after the door has been closed.

1-6 PANIC WITH IGNITION ON: This feature controls whether or not the panic mode is available with the ignition on. In some states, there are laws prohibiting a siren sounding in a moving vehicle. This feature makes the system compliant with these regulations.

1-7 DOOR LOCK PULSE DURATION: The default setting is 0.8 second door lock pulses. Some European vehicles, such as Mercedes-Benz and Audi, require longer lock and unlock pulses to operate the vacuum pump. Programming the system to provide 3.5 second (2) pulses, accommodates the door lock interface in these vehicles. (Refer to Tech Tip 1041 on Directechs, for wiring information regarding Type E door locks interfacing). The 0.4 second (3) pulse is required on some vehicles where the lock wires also control the windows. The 0.8 second pulse causes the windows to open/close when locking or unlocking.

1-8 FORCED PASSIVE ARMING ON/OFF: To use this feature, passive arming must be selected in Feature 1-1. When turned on, forced passive arming will ensure that the system will passively arm, even if a zone is left open or invalid. Forced passive arming occurs one hour after the ignition is turned off.

1-9 AUTOMATIC ENGINE DISABLE (AED) ON/OFF: AED is a full-time, passive starter disable that works independently of the security system. When turned on, the orange, ground-when-armed output (H1/1) will activate 30 seconds after the ignition is turned off. The LED will flash at half its normal rate when the ignition is turned off to indicate that AED is active and will interrupt the starter in 30 seconds. AED does not occur in Valet mode and can be bypassed using the emergency override procedure. The transmitter can be used to disarm AED, however, the system must be armed and then disarmed, using the transmitter, to disarm AED.

1-10 ARMED WHILE DRIVING (AWD) ON/OFF: In the default setting (Armed While Driving), the system can be armed with the ignition on. When armed, the ground-when-armed is not active and the sensors are bypassed. The door triggers will remain active.

1-11 CODE HOPPING® ON/OFF: The system uses a mathematical formula to change its code each time the transmitter and receiver communicate. This makes the group of bits or "word" from the transmitter very long. The longer the word is, the easier it is to block its transmission to the unit. Disabling the Code Hopping® feature lets the receiver ignore the Code Hopping® part of the transmitted word. As a result, the unit may have better range with Code Hopping® off.

1-12 HORN OUTPUT PULSED/CONSTANT: Program for either a pulsed output or a continuous output when triggered.

1-13 HORN FUNCTION (FULL ALARM ONLY)/SIREN FUNCTION (20mS, 30mS, 40mS, 50mS): Program for output when the alarm is fully triggered or as the siren (arming/disarming and warnaway and full trigger with timing options).

1-14 COMFORT CLOSURE—ON (1), OFF (2) Comfort Closure 2 (3): The system can be programmed to close the windows when the system is locked. If programmed On, the lock output provides a 20 second pulse when the system is locked. The output is cancelled if the unlock button is pressed. In the Off setting the alarm does not perform this function.

(2) Comfort closure 1 - Activates the 20 second timer after the door lock pulse.

(3) Comfort closure 2 - Activates the 20 second timer with the door lock pulse.

To test if the car has the comfort closure:

1. Insert the key into the drivers door key cylinder.
2. Turn the key to the lock position and hold for about 10 seconds. Some cars require that you turn the key once, release, and then turn and hold into the lock position.

If Comfort closure is available, the windows (and in some cars the sunroof) close.

Important: Comfort closure can only be used on cars that have the capability of closing the windows (and on some cars the sunroof as well) with the key cylinder in the door.

► Menu 2 - Advanced

2-1 SIREN DURATION 30/60 SECONDS: It is possible to program the unit to sound for 30 or 60 seconds during the triggered sequence. Some states have laws regulating how long a security system can sound. When using the Bitwriter®, the siren can be programmed to sound for any length of time from 1 second to 180 seconds.

2-2 NUISANCE PREVENTION® CIRCUITRY (NPC) ON/OFF: NPC stops repeated triggering of the same zone. If one zone is triggered three times in one hour, that zone is bypassed for one hour, starting from the time of the third trigger. During that hour, if the system sees a trigger on that zone again, the system resets the one hour timer. If one hour passes and the zone has not triggered again, the zone is activated and can trigger the system again. NPC only monitors sensor inputs, and does not bypass the door trigger or the ignition trigger at any time. If NPC is turned off, the system will respond to repeated triggers on the sensor inputs and will do so indefinitely. Some states have laws regulating how many times a security system can trigger before it is considered a nuisance and the vehicle is towed away.

2-3 PROGRESSIVE DOOR TRIGGER ON/OFF: The system responds to a door trigger input with a progressive response. When the door is opened with the system armed, the siren will chirp 10 times prior to the full triggered sequence. The door trigger is still treated as an instant trigger and closing the door quickly will not prevent full triggered sequence from occurring. If the progressive door trigger is programmed off, the full siren output will occur the moment the door is opened.

2-4 VALET DISARM PULSE COUNT 1 TO 5 PULSES: The system can be programmed to count the number of presses of the valet switch before disarming the security system. The factory default setting is one pulse. The unit can also be set for two to five pulses.

Ghost Switch option: For added security, the GRAY wire on the two-pin Valet/Program plug can be connected to any switch in the vehicle that provides a positive (+) momentary pulse.

2-5 DOOR TRIGGER ERROR ON/OFF: This feature controls the error chirp that is generated if the system is armed with the door trigger active. This is useful in vehicles that have a long dome light delay after the door has been closed. If the system is armed before the dome light has turned off, the security system will generate the door trigger error chirp. If this error chirp is not desired, use this feature to disable the door open error chirp. If the bypass chirp is turned off, no bypass chirp will be generated, even if a door is accidentally left open.

2-6 IGNITION CONTROLLED DOME LIGHT SUPERVISION ON/OFF: If turned on, the system will turn on the dome light for 60 seconds when the ignition is turned off. The optional dome light supervision feature must be installed as described in the Wire Connection Guide.

2-7 UNLOCK OUTPUT—1, 2 PULSES: This will program the unlock output to one or two pulses. When the double pulse unlock feature is turned on, the BLUE door lock harness wire will supply two negative pulses instead of a single pulse. At the same time, the GREEN door lock harness wire will supply two positive pulses instead of a single pulse. This makes it possible to directly interface with double pulse vehicles without any extra parts for unlock and lock outputs (see below).

2-8 LOCK OUTPUT—1, 2 PULSES: This will program the lock output to one or two pulses. When the double pulse lock feature is turned on, the BLUE door lock harness wire will supply two positive pulses instead of a single pulse. At the same time, the GREEN door lock harness wire will supply two negative pulses instead of a single pulse.

2-9 FACTORY ALARM DISARM WITH TRUNK RELEASE In the default setting the factory alarm disarm output will disarm the factory alarm system any time the button(s) controlling trunk release is pressed.

2-10 FACTORY ALARM DISARM—WITH UNLOCK, BEFORE UNLOCK, REMOTE START ONLY: In the default setting the factory alarm disarm output will disarm the factory alarm system any time the button(s) controlling Unlock is pressed. The "Before Unlock" output disarms the factory alarm before the unlock output activates and before remote start is activated. The "Remote Start Only" output disarms the factory alarm only before the remote start is activated.

2-11 FACTORY ALARM DISARM PULSES—SINGLE, DOUBLE: Selectable for a single or double-pulse for the vehicle's factory alarm disarm input requirements.

2-12 AUX 1 VALIDITY/LATCHED/LATCHED RESET WITH IGNITION/30 SECOND TIMED OUTPUT: This wire provides a (-) 200mA output whenever the transmitter button(s) controlling AUX 1 is pressed. This output can be programmed to provide the following types of outputs (see also the Feature Menu section):

- Validity: Output that will send a signal as long as the transmission is received.
- Latched: Output that will send a signal when the Aux 1 button is pressed and will continue until the same button(s) is pressed again.
- Latched, reset with ignition: Similar to the latched output, this type of output turns on the first time the Aux 1 button is pressed and turns off the next time the same button is pressed. This type of output additionally stops and resets whenever the ignition is turned on and then off.
- 30-second timed: Output that will send a continuous signal for 30 seconds.

Note: All auxiliary channel timed outputs can be programmed using the Bit writer® (1-90 seconds).

2-13 Aux 1 LINKING (NONE)/ARM, DISARM, REMOTE START: When programming to validity or timed output this can be programmed to activate when arming or disarming (or remote starting) with the transmitter.

2-14 AUX 2 VALIDITY/LATCHED/LATCHED RESET WITH IGNITION/30 SECOND TIMED OUTPUT: AUX 2 can be programmed for these output configurations. The unit is set to the default validity output. To change the configuration, use the two-chirp setting to toggle through the different configurations. Refer to feature 2-10 for additional detail.

2-15 AUX 2 LINKING (NONE)/ARM, DISARM, REMOTE START: Refer to feature 2-13 for additional detail.

2-16 AUX 3 VALIDITY/LATCHED/LATCHED RESET WITH IGNITION/30 SECOND TIMED OUTPUT: AUX 3 can be programmed for these output configurations. The unit is set to the default validity output. To change the configuration, use the two-chirp setting to toggle through the different configurations. Refer to

feature 2-10 for additional detail.

2-17 AUX 3 LINKING (NONE)/ARM, DISARM, REMOTE START: Refer to feature 2-13 for additional detail.

► Menu 3 - Remote start

3-1 Engine Checking Virtual Tach: (1) When set to "virtual tach" (1) the remote start monitors the cranking voltage of the vehicle and sets it as a reference point. Fifteen seconds after the crank output sequence the remote start checks the voltage again to determine if the vehicle is running.

When set to voltage, (2) the unit cranks the starter for the programmed time and then attempts to sense that the engine is running by detecting an increase in voltage. If programmed Off (3) the vehicle cranks for the programmed crank time. The tach setting or voltage setting is not checked to verify that the car is running. In the OFF setting, if the vehicle fails to start, the ignition stays on for the run duration. Using tach or either of the voltage settings is recommended.

When set to Tachometer, (4) the unit references the learned tach signal to disengage the starter. In addition it will monitor the RPM and shut down if the engine RPM is too high or too low.

3-2 RUN TIME 12, 24, 60 MINUTES: Selects the time in minutes that the system will operate the engine until the system "times out". This is the maximum operation period and the system may be shut down using a shutdown at any time. Using the Bitwriter®, the run time can be programmed for any duration from 1-60 minutes.

3-3 Parking Lights Constant: In the default setting, the parking lights (if connected) will come on solid during the remote start runtime. In the two-flash setting the parking lights will flash during the remote start runtime. In the OFF setting, the parking lights will not come ON or flash, when the vehicle is remote started.

3-4 CRANK TIME 0.6/0.8/1.0/1.2/1.4/1.6/1.8/2.0/4.0 SECONDS: If the unit is programmed for no engine checking or voltage sense, the crank time must be set to the appropriate duration. The default setting is 0.6 second. If a different crank time is desired, select feature 3-5 and select either 0.6 second by using the one-chirp setting or toggle through the higher settings by using the two-chirp settings.

3-5 ACTIVATION PULSE 1: This allows the system to use 1 or 2 pulses to activate the remote start sequence. The default setting is 1-pulse.

Note: This setting affects both the input wire and the remote control.

3-6 2nd IGNITION/ACCESSORY OUTPUT: This will allow the PINK/WHITE to be used as a 2nd ignition or an accessory. The default is 2nd ignition.

3-7 ACCESSORY STATE DURING WAIT-TO-START OFF/ON: This feature will allow the selection of the accessory output to be ON or OFF during wait-to-start.

3-8 2nd STATUS OUTPUT NORMAL/REAR DEFOGGER LATCHED 10-MIN/PULSE: This feature will allow selection of status output or a rear defogger mode that turns on ten seconds after the vehicle has started if the vehicle interior temperature is below 55 degrees F. The defogger mode has two selections, latched or pulsed. Latched mode will only stay on for 10 minutes.

3-9 ANTI-GRIND ON/OFF: With the anti-grind On (default) the ground-when-armed output will be active during remote start operation. If accessories such as a voice module or window module are added to the unit, it may be necessary to program this feature off.

3-10 DIESEL TIMER—WAIT-TO-START/15, 30, 45 SECONDS: Default is the "Wait-to-Start" input control wire, or programmable to ignore the input control wire by a delay of 15, 30, or 45 seconds. This feature can also be programmed with the Bitwriter® and with a delay from 1 to 90 seconds.

3-11 RUN TIME (TIMER MODE)—12, 3, 6, 9 MINUTES: Selects the time in minutes that the system will operate the engine until the system "times out". This is the maximum operation period and the system may be shut down using a shutdown at any time. Using the Bitwriter®, the run time can be programmed for any duration from 1-16 minutes.

3-12 TIMER MODE—TIMED STARTS/TEMPERATURE STARTS: The system will start every 3-hours until canceled by the brake, hood, or neutral safety shut-down wires (a maximum of 6 times). The temperature start mode will not start the vehicle unless the interior temperature of the vehicle is less than 0 degrees F. The temperature start mode will exit after 18 hours.

3-13 SHORT RUN/TURBO 1/3/5/10 MINUTES: When the  and **AUX** buttons on the transmitter are pressed simultaneously, the vehicle will start for the programmed short run time. The factory default is 1 minute.

NPC, Valet Mode, Rear defogger, Timer Mode

For information on Nuisance Prevention Circuitry (NPC), Valet Mode, Rear Defogger control and Timer Mode, refer to the Owner's Guide at [www. Directed.com](http://www.Directed.com).

Table of zones

When using the Diagnostic functions, use the Table of Zones to see which input has triggered the system. It is also helpful in deciding which input to use when connecting optional sensors and switches.

Zone No.	Trigger Type	Input Description
1	Trunk Input	BLUE (H1/7)
2	Multiplexed Shock Sensor Input	Mux BLUE wire.
3	Door Trigger	GREEN (H1/8) and VIOLET (H1/6).
4	Multiplexed Shock Sensor Input	Mux GREEN wire
5	Ignition	Yellow ribbon harness wire
6	Hood Brake Trigger	GRAY on the 6-pin shutdown harness

Shutdown diagnostics

To perform shutdown diagnostics:

1. With the ignition OFF, press and hold the Valet/Program switch.
2. Turn the ignition ON and then back OFF while holding the Valet/Program switch.
3. Release the Valet/Program switch.
4. Press and release the Valet/Program switch. The LED flashes on the control center to report the last shutdown for one minute or until the ignition is turned on, as shown in the following table:

LED Flashes	Shutdown Mode
1	Timed out
2	Over-rev shutdown
3	Low or no RPM
4	Transmitter shutdown (or optional push button)
5	(+) Brake shutdown
6	(-) Shutdown (H3/4 GRAY) or (+) Shutdown (H3/3 BROWN)
7	(-) Neutral safety shutdown (H3/1 BLACK/WHITE)
8	Wait-to-start timed out

Safety check

Before vehicle reassembly, the remote start system must be checked to ensure safe and trouble-free operation. The following test procedure must be used to verify proper installation and operation of the system. The installation must be completed before testing, including connection to the brake switch and hood switch.

1. Test the BRAKE shutdown circuit: With the vehicle in Park (P), activate the remote start system. Once the engine is running, press the brake pedal. The engine should shut down immediately. If the engine continues to run, check the brake circuit connection.
2. Test the HOOD PIN shutdown circuit: With the vehicle in Park (P), open the hood. Activate the remote start system. The vehicle should not start. If the starter engages, check your hood pin and connections.
3. Test the NEUTRAL SAFETY shutdown circuit.

<p>Important: Make sure there is adequate clearance to the front and rear of the vehicle before attempting this test.</p>
--

4. Make sure the hood is closed and no other shutdown circuits are active.
 5. Set the emergency brake.
 6. Turn the ignition key to run position but do not start the engine.
 7. Put the vehicle in Drive (D).
 8. Put your foot over the brake pedal but do not press down on it. Be ready to step on the brake to shutdown the remote start system.
 9. Activate the remote start system.
- If the starter engages, immediately step on the brake to shut down the system. If it does engage, recheck the neutral safety input connection. The vehicle may use a mechanical neutral safety switch. (See H3/1 BLACK/WHITE neutral safety switch input in Remote Start Harness Wire Connection Guide section of this guide.)
 - If the starter does not engage, the test is complete. Once the system passes the tests, the vehicle can be re-assembled and delivered. Do not use the remote start system or finalize the installation if it fails any of the safety check tests.

➤ Alarm

- **Shock sensor doesn't trigger the alarm:**

Has the NPC system been triggered? If so, you will hear 5 chirps when disarming. To check this, turn the ignition key on and off to clear the NPC's memory, and then retest the shock sensor. For a detailed description of NPC, see Nuisance Prevention® Circuitry section of the Owner's Guide.

- **Door input does not immediately trigger full alarm. Instead chirps are heard for the first 3 sec**

That's how the progressive two-stage door input works! This is a feature of this system. This is an instant trigger, remember, since even if the door is instantly closed again, the progression from chirps to constant siren will continue.

- **Closing the door triggers the system, but opening the door does not:**

Have you correctly identified the type of door switch system? This happens often when the wrong door input has been used. (See Door Lock Harness Wire Connection Guide section of this guide.)

- **System does not passively arm until it is remotely armed and then disarmed:**

Are the door inputs connected? Is the H1/6 blue wire connected to the door trigger wire in the vehicle? Either the H1/5 green or the H1/7 violet should be used instead. (See wiring diagrams.)

- **Door input does not respond with the progressive trigger, but with immediate full alarm:**

Does the Status LED indicate that the trigger was caused by the shock sensor? (See Diagnostics section of this guide.) The shock sensor, if set to extreme sensitivity, may be detecting the door unlatching before the door switch sends its signal. Reducing the sensitivity can solve this problem.

- **The Valet/Program switch doesn't work.**

Is it plugged into the correct socket? See Plug-In LED and Valet/Program Switch section of this guide.

- **Status LED doesn't work.**

You've probably guessed already, but here goes: Is it plugged in? (See Plug-In LED and Valet/Program Switch section of this guide.) Is the LED plugged into the correct socket?

- **Door locks operate backwards.**

This unit has easily-reversed lock/unlock outputs. Recheck wire connections to see if you have reversed these.

➤ Remote start

- **The remote start will not activate**

1. Check the harnesses and their connections. Make sure that the harnesses are completely plugged into the remote start module. Make sure there are good connections to the vehicle wiring.
2. Check voltage and fuses on the main 12-pin harness and on the heavy gauge remote start harness.
3. Check diagnostics. The diagnostics will tell you which shutdown is active or not connected.

- **The remote start will activate, but the starter never engages.**

1. Check for voltage on the purple starter wire two seconds after the remote start becomes active. If there is voltage present, skip to Step 4. If there is not voltage present, advance to Step 2.
2. Check the 30A fuses.
3. If the gray/black wait-to-start wire is detecting ground upon activation, the starter will not crank.
4. Make sure the purple starter wire is connected on the starter side of the optional starter kill/anti-grind relay.
5. Does the vehicle have an immobilizer? Some immobilizer systems will not allow the vehicle to crank if active.
6. Check connections. The heavy gauge remote start input wires on the heavy gauge 10-pin connector should have a solid connection. "T-taps" or "scotch locks" are not recommended for any high current heavy gauge wiring.

- **The vehicle starts, but immediately dies.**
 1. Does the vehicle have an immobilizer? The vehicle's immobilizer will cut the fuel and/or spark during unauthorized starting attempts.
 2. Is the remote start programmed for virtual tach voltage sense? If so, the crank time may not be set high enough. Voltage sense will not work on some vehicles.
 3. Check diagnostics. Sometimes a shutdown will become active during cranking or just after cranking.

- **The vehicle starts, but the starter keeps running.**
 1. Is the system programmed for engine checking off or virtual tach voltage sense? When programmed for either of these features, the engine cranks for the pre programmed crank time regardless of how long it takes for the vehicle to actually start. Adjust to a lower cranking time.
 2. Was the Tach Learn successful? The LED must light solid and bright to indicate a successful learn.
 3. Make sure that there is a tach signal at the purple/white tach input wire of the remote start. If there is not a tach signal, recheck the connection to the vehicle's tach wire and make sure the wire is not broken or shorted to ground leading to the remote start.

- **The vehicle starts, but will only run for 10 seconds.**
 1. Is the remote start programmed for voltage sense? If this does not work, a tach wire should be used.
 2. Check shutdown diagnostics.

- **The climate control system does not work while the unit is operating the vehicle.**

Either the wrong accessory wire is being energized or more than one ignition or accessory wire must be energized in order to operate the climate control system.

Wiring quick reference guide

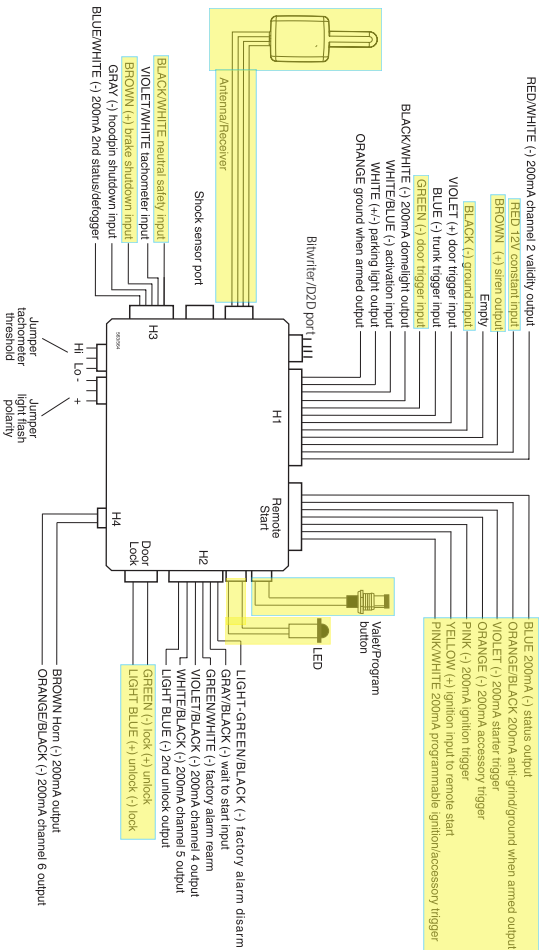

These signals are from the Relay Satellite ribbon harness and are provided to drive additional optional relays.

