

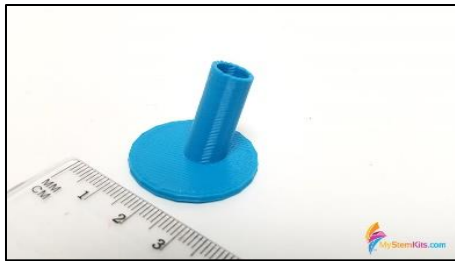

WFM-SFT-0817

Quantity: 3



Stand Foot*

WFM-CAN-0717

Quantity: 2

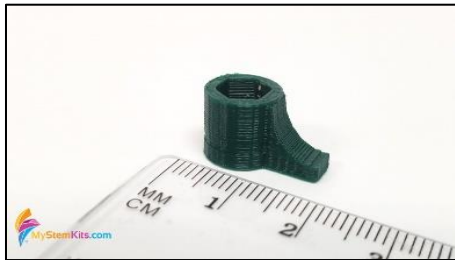

Axle Centerer

WFM-WG4-0915

Quantity: 3



Weight

WFM-STP-0817

Quantity: 1



Stand Top*

WFM-ASP-0817

Quantity: 1

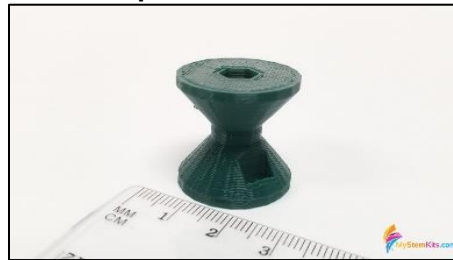

Spool

WFM-P55-0717

Quantity: 1



Sample Fan 5 Blade Pointed

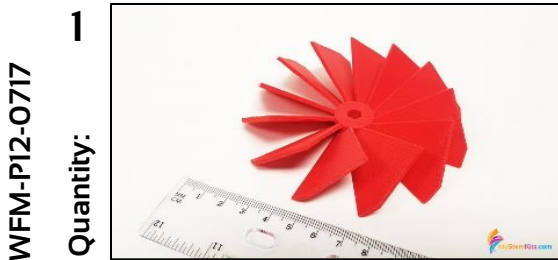

Sample Fan 12 Blade Pointed

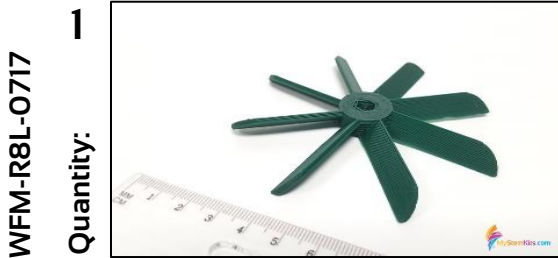

Sample Fan 8 Blade Rounded



String or Thread

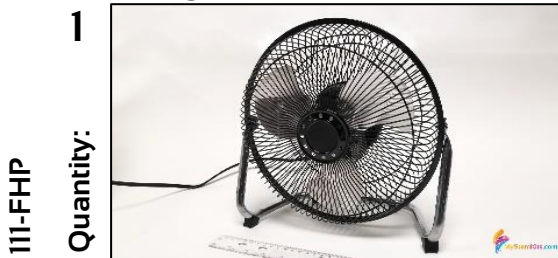

High-Powered Fan



Sample Fan 3 Blade Rounded



#2 Pencil

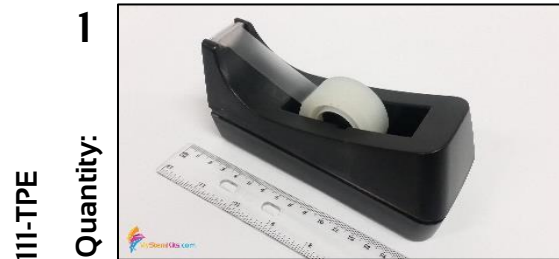

Tape

Our blades were created in Tinkercad. You can create your own alternates if you so choose. Refer to the included Design Guide for how to do so.

The parameters we used to create ours are as follows:

Blade	Style	# of Blades	Length	Angle	Point Width	Point Distance
WFM-R3S-0717	Rounded	3	16	45°	NA	NA
WFM-R8L-0717	Rounded	8	45	45°	NA	NA
WFM-P5S-0717	Pointed	5	40	45°	20	10
WFM-P12-0717	Pointed	12	45	45°	35	30

Length, Point Width and Point Distance are measured in mm. Refer to page 10 for an explanation of the parameters.

*If you already have a **Meter Stick Stand**, you can replace the **stand feet** and **stand top** with the following pieces and replace Steps 1 and 2 in the Assembly Guide with Steps A1 to A3 at the end of the Assembly Guide.



Kits which contain the **Meter Stick Stand** (pictured below) as of August 2017:

- Pulley System Kit
- Planetary Temperatures Kit
- Thin Meter Stick Ramp Kit
- Water Filtration Kit
- Wide Meter Stick Ramp Kit

Assembly instructions for the stand are provided in the aforementioned kits' model guides. Note, the Meter Stick Stand is not required to use this kit. The **meter stick axel** is provided as an alternate for convenience.



Step 1:

Insert 3 pencils into the **stand top** with erasers pointing downward,

*If using the meter stick stand alternative, replace Steps 1 and 2 with A1 to A3.



Step 2:

Insert the eraser end of each pencil into a **stand foot**.

You will need to rotate each **foot** to ensure that it lies flat on the surface.

Each **foot** should be taped down to prevent movement from the fan.



Step 3:

Slide the **spool** onto the fourth pencil with the hole on the end opposite the eraser.

Slide the **spool** all the way to the metal.



Step 4:

Slide one **centerer** about halfway down the pencil with the rounded section facing away from the spool and eraser.



Step 5:

Slide the pencil through the holes in the stand top up to the **centerer**. Slide the remaining **centerer** onto the pencil up to the **stand top** with the rounded section pointing toward the **stand top**.



Step 6:

Push the desired **blade** onto the end of the pencil.

Make sure the windmill assembly sits level. You'll have to adjust this for each **blade**. Simply slide the **centerers** back and forth until balanced. Make sure to readjust the **centerers** afterwards to make sure it spins freely but is not too loose.

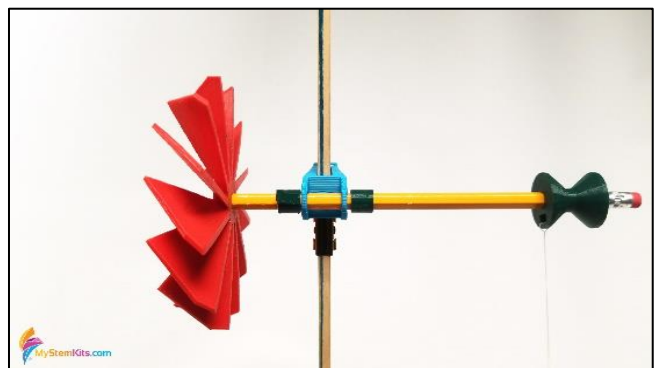

Step 7:

Tie one end of string to the hole in the side of the **spool** and the other end to the hook of a **weight**.

Weights can be hooked together to increase the load on the windmill.



Step 8:

Blow the windmill with a fan and measure the time it takes to pull up the **weight(s)**.

Make sure to control all variables between experiments:

- Distance between windmill **blade** & fan
- Speed of fan
- Length of string
- Starting technique
- String location (make sure it spools onto the spool, not the pencil)
- Etc.



Step 9:

To change **blades**, pull the previous **blade** off the pencil and push on the new **blade**.

Be sure to re-balance your pencil before conducting the test on the new **blade**. Ensure that it sits level and spins freely.

Refer to the Design Guide for how to create custom **blade** designs.



***If using the meter stick stand, replace Steps 1 and 2 with A1 – A3, then return to step 3.**

Step A1:

Assemble the meter stick stand (see page 3).

Place the binder clip on the meter stick just below the height you want the windmill to be at.

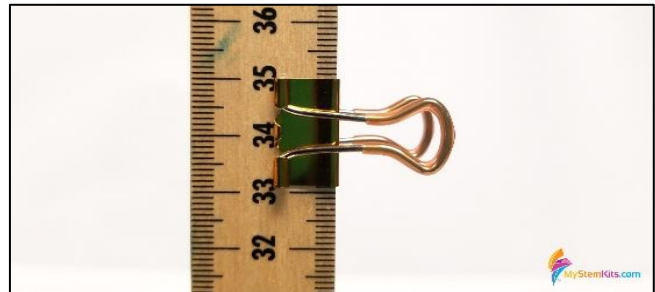

Step A2:

Place the **meter stick axle** on the meter stick, resting on the binder clip.

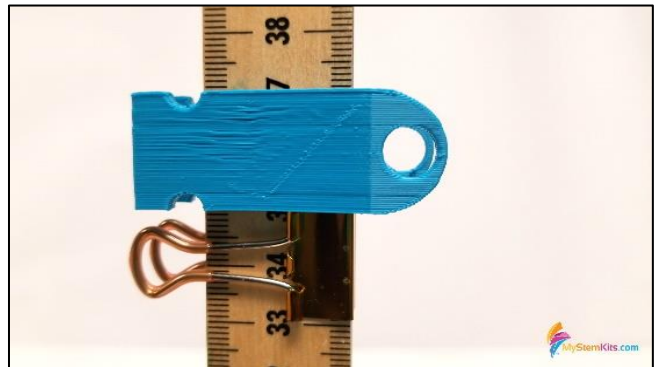

Step A3:

Wrap the rubber band around the **meter stick axle** repeatedly until it is securely in place.

Tape the meter stick stand in place, so it doesn't move when the fan is turned on.

Return to step 3 of the Assembly Guide, using the **meter stick axle** instead of the **stand top** in future steps.

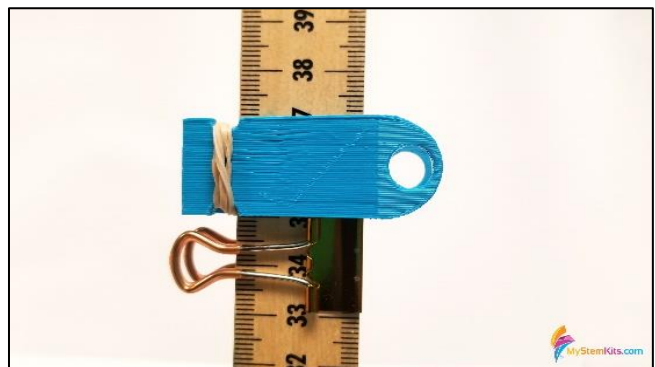

Step 1:

Open a new workspace and add a ruler to help position parts.

Position the ruler on the bottom left corner of the workspace.

Change the ruler to midpoint mode by clicking the icon under the x which appears as a circle with 3 lines inside it.

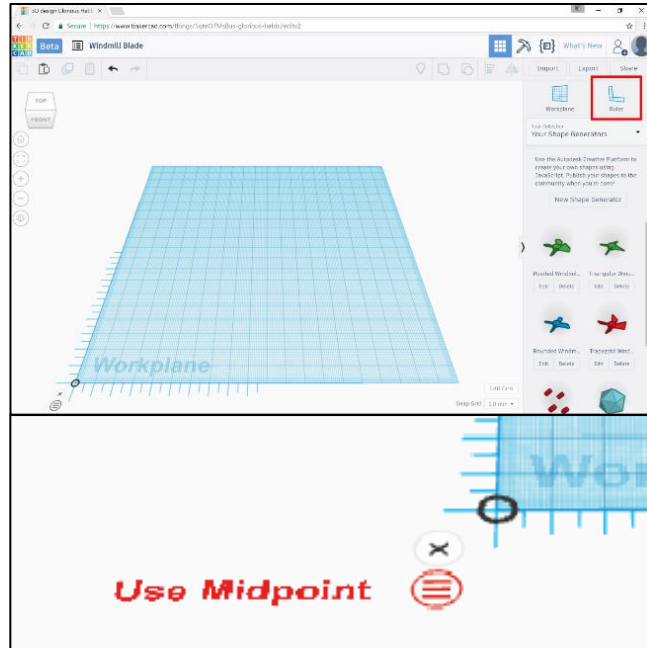

Step 2:

Drag in the desired blade type from the community shape generators menu in the sidebar.

The available blade types are rounded, pointed, and trapezoidal.

Refer to page 2 for the settings our sample blades used.

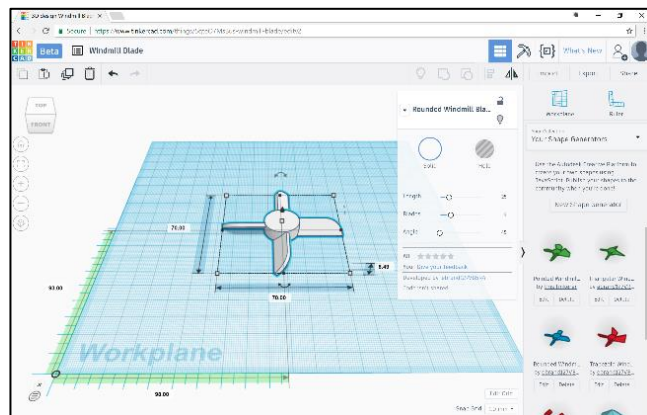

Step 3:

Position the midpoint of the blade on the ruler by changing the distances from the ruler to 0.

This will make it easier in later steps to position more parts.

Leave the upward distance where it is.

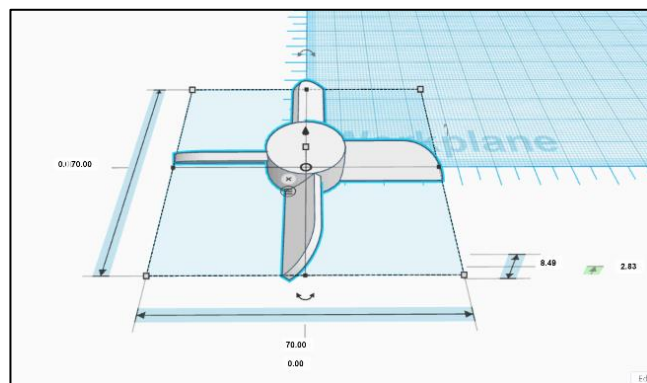

Step 4:

Modify the blade using the sliders or by typing in numbers and pressing enter.

Refer to page 10 for the different parameters of each blade type.

Angle can be changed but we suggest leaving it at 45 degrees.

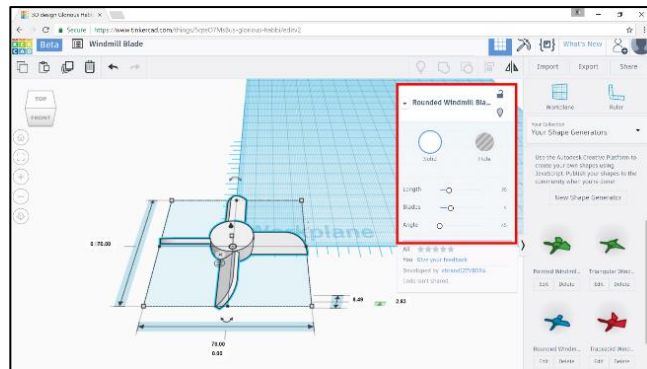

Step 5:

Drag in a **polygon** from the **basic shapes** menu in the sidebar. Make sure the shape is a regular hexagon with 6 sides.

This will be used to make the hole for the blade to fit onto the pencil.

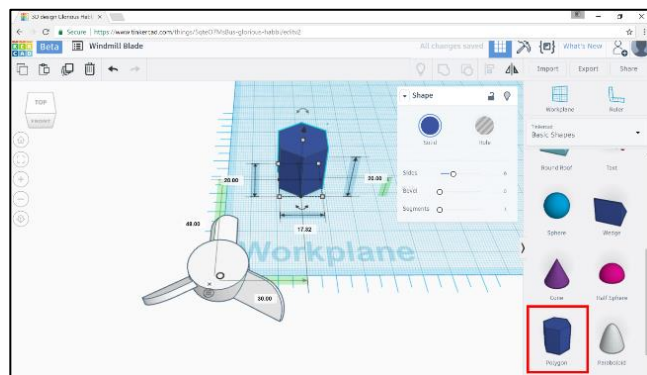

Step 6:

Resize the hexagon to 8.25 in the longer direction (point to point) and 7.145 in the shorter direction (flat to flat).

Change to hole instead of solid and center it the same as the blade by changing the distances from the ruler to 0.

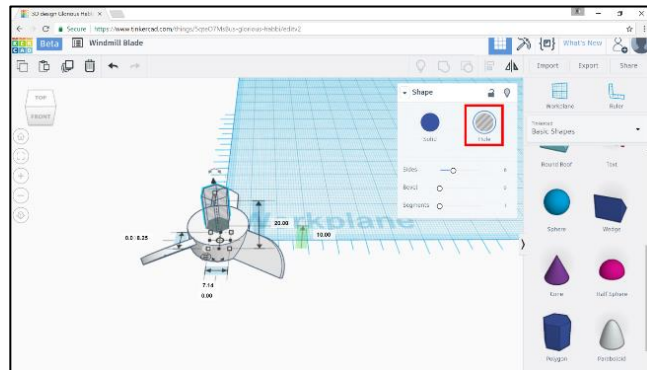

Step 7:

Drag in a **box hole** from the **basic shapes** sidebar menu.

This will be used to make the bottom of the blade flat to print easily.

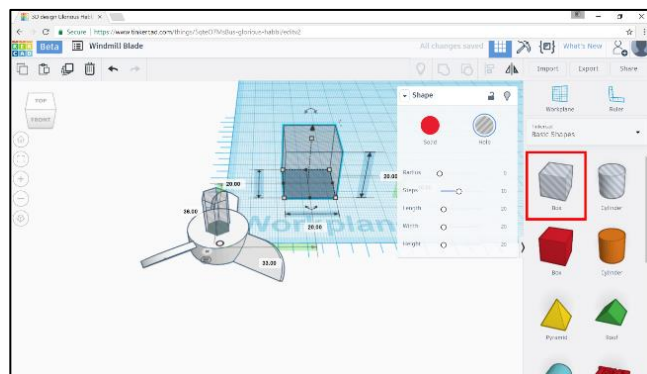

Step 8:

Change the height of the box to 2 and the upward distance to -1. This will make sure the box removes the material below the workspace and nothing more.

Position the box in the same way as the blade and hexagon, then expand it until it is larger than the blade.

Expand the box typing numbers, not by dragging so that it stays in position.

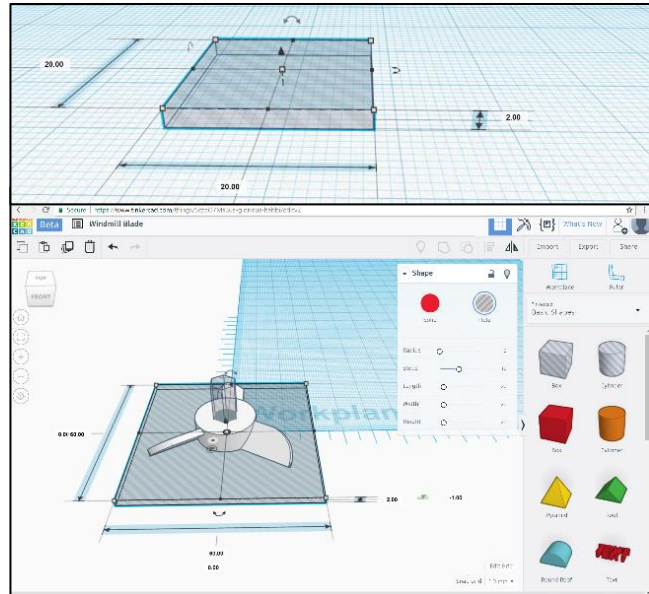

Step 9:

Select all the parts and combine them by clicking the group button.

This will make them into one part and the hole parts will remove material from the blade to create a hole and make the bottom flat.

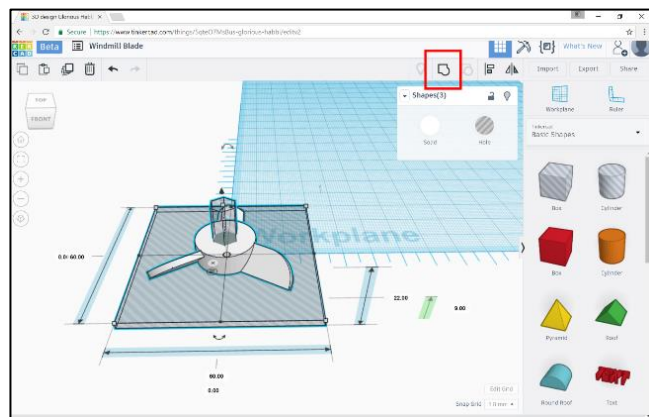

Step 10:

The blade is now ready and can be exported as an STL to print.

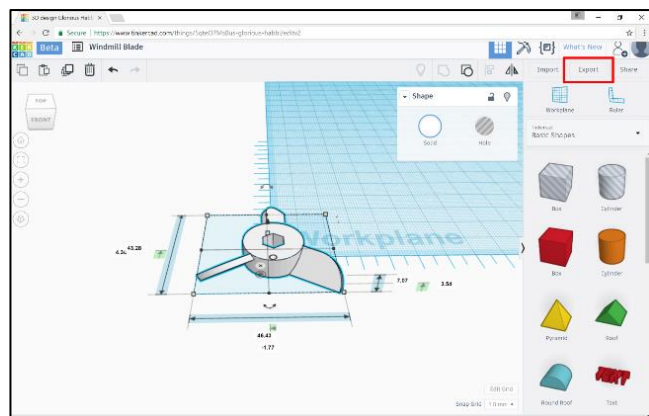
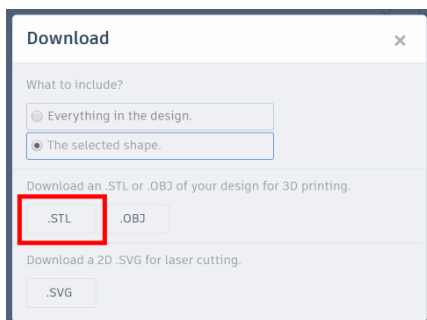

To make changes to the **blade**, ungroup the parts to change each individually.

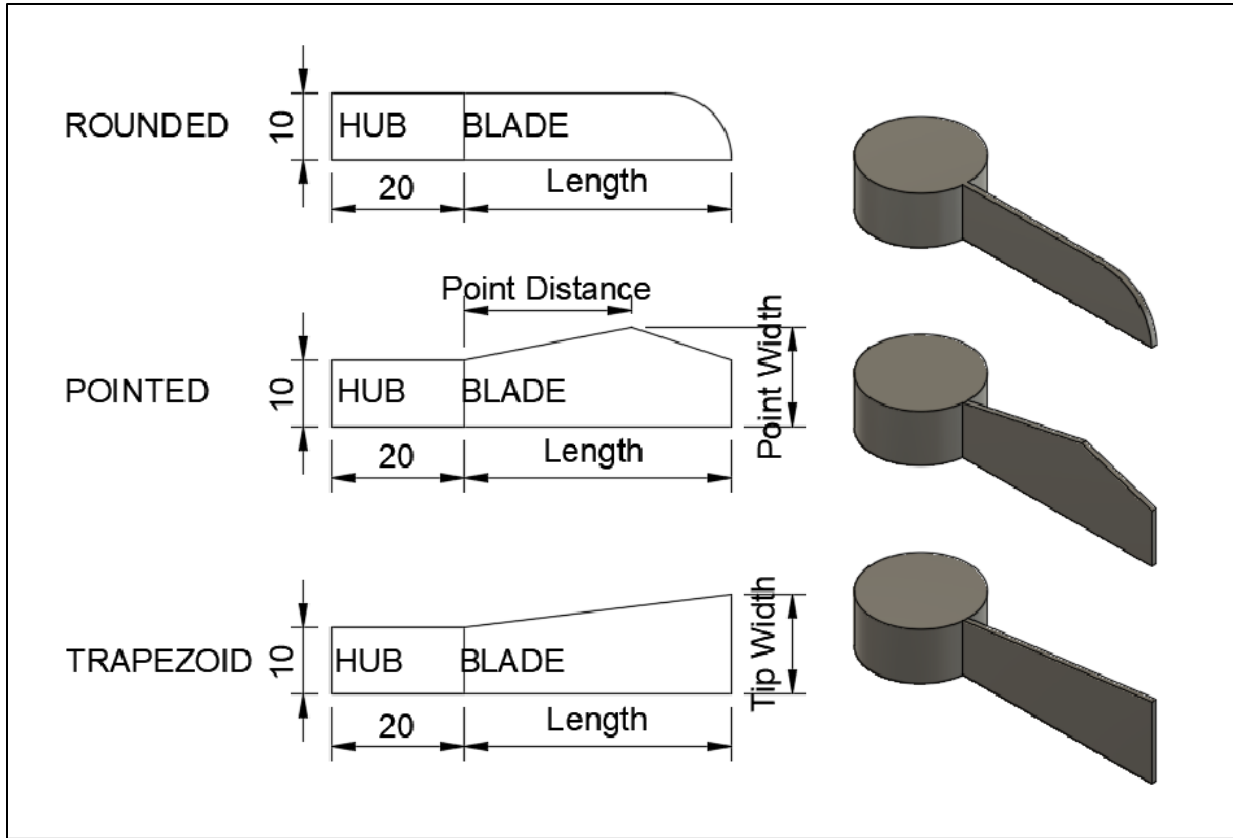

Side views of single blade at 90 degrees (upright) for each blade type (above)
Sample alternate blade designs (below)

