

PARTS LIST			
ITEM	QTY	PART NUMBER	DESCRIPTION
1	1	001-001_FixedJaw	
2	1	001-002_MovableJaw	
3	1	001-003_BackerBlock	
4	2	001-004_GuideRod	
5	2	8-32 Button Head Screw	8-32 x 1 UNC Button Head Screw
6	1	10-24 Socket Cap Screw	Assorted Lengths

DRAWN		TITLE 000-001 Full Assembly		
CHECKED				
QA				
MFG				
APPROVED				
		SIZE	DWG NO	REV
		B	000-001_FullAssemblyDrawing	
		SCALE	SHEET 1 OF 1	
		1 : 1		

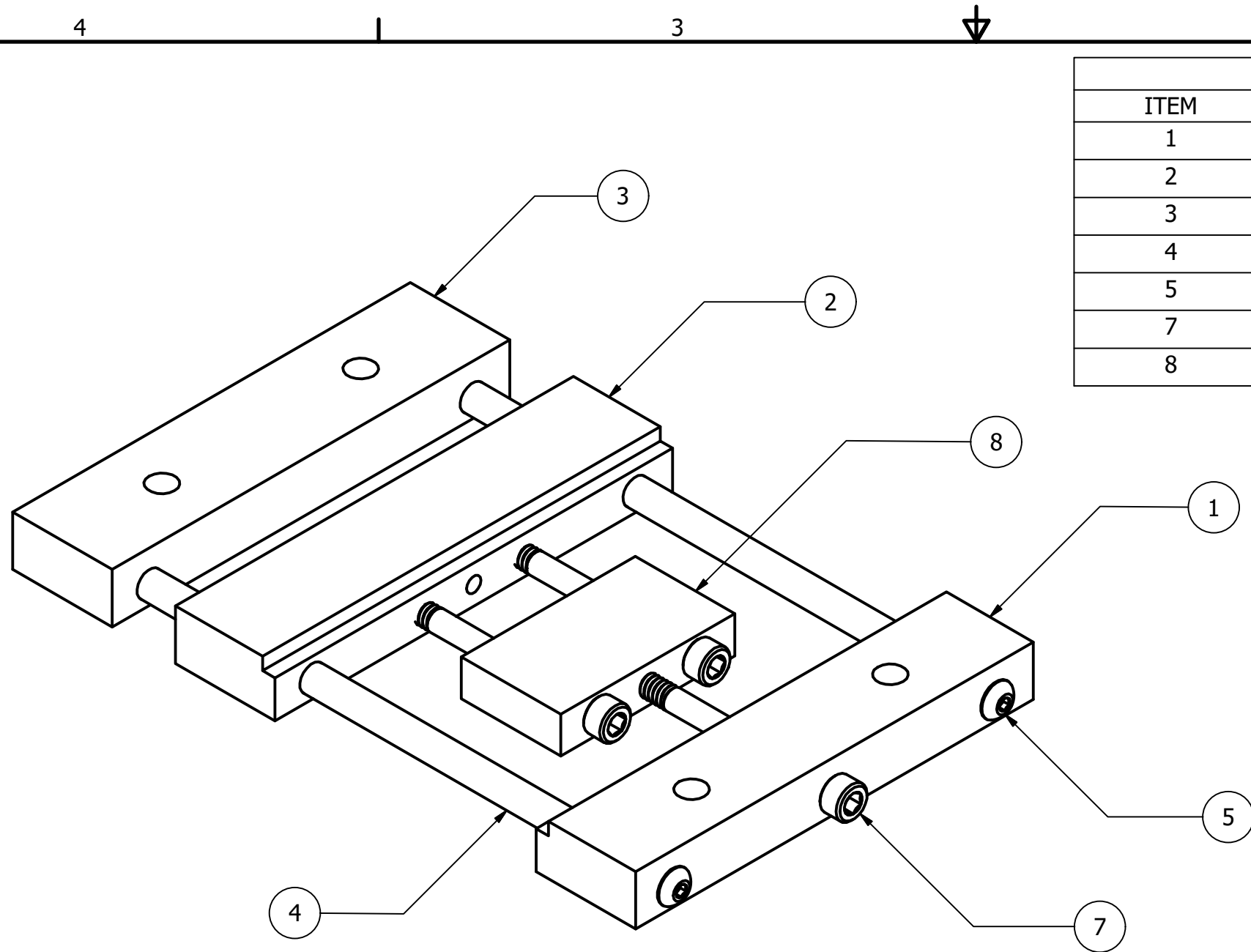

PARTS LIST			
ITEM	QTY	PART NUMBER	DESCRIPTION
1	1	001-001_FixedJaw	
2	1	001-002_MovableJaw	
3	1	001-003_BackerBlock	
4	2	001-004_GuideRod	
5	2	8-32 Button Head Screw	8-32 x 1 UNC Button Head Screw
7	3	10-24 Socket Cap Screw	Assorted Lengths
8	1	001-005_ExtenderBlock	

DRAWN		TITLE 000-001 Full Assembly Extended		
CHECKED				
QA				
MFG				
APPROVED				
		SIZE	DWG NO	REV
		B	000-001_FullAssemblyExtended	
		SCALE	SHEET 1 OF 1	
		1 : 1		

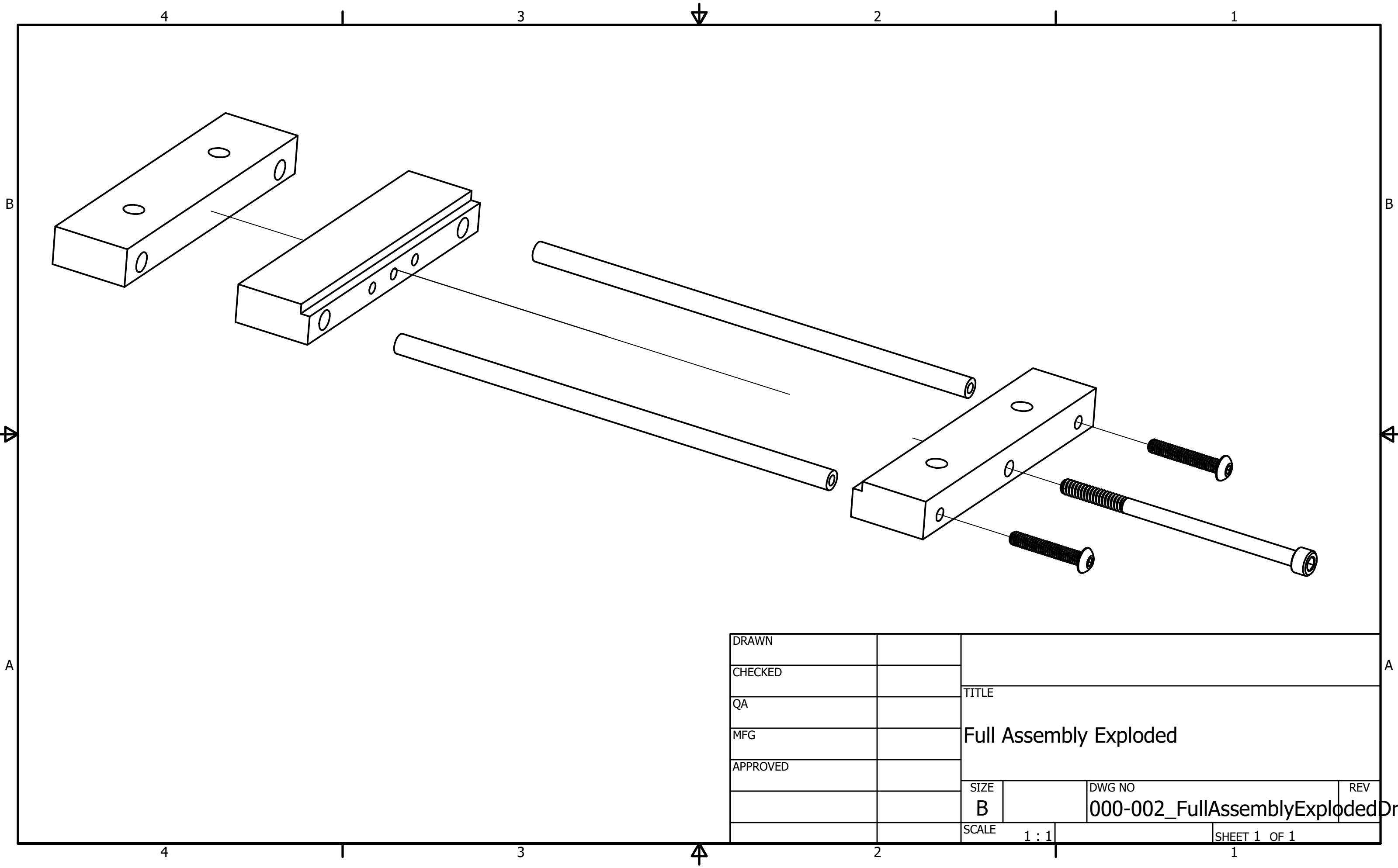

DRAWN		TITLE		
CHECKED				
QA		Full Assembly Exploded		
MFG				
APPROVED				
		SIZE	DWG NO	REV
		B	000-002_FullAssemblyExploded	Draw
		SCALE	1 : 1	SHEET 1 OF 1

4 3 2 1

B

B

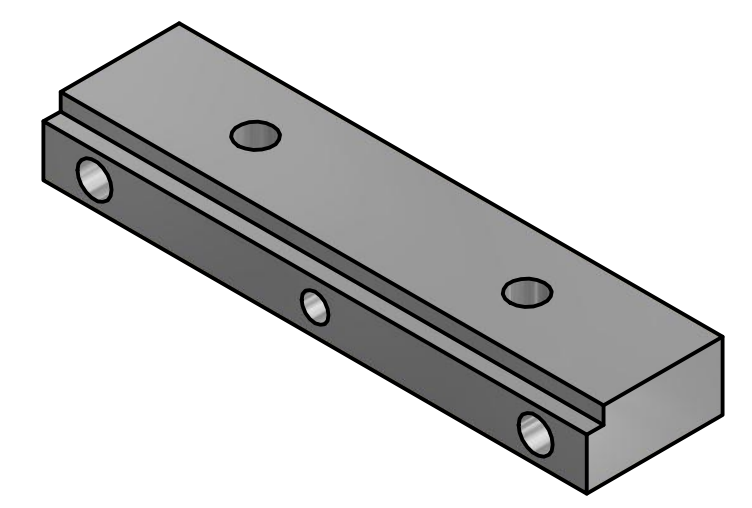
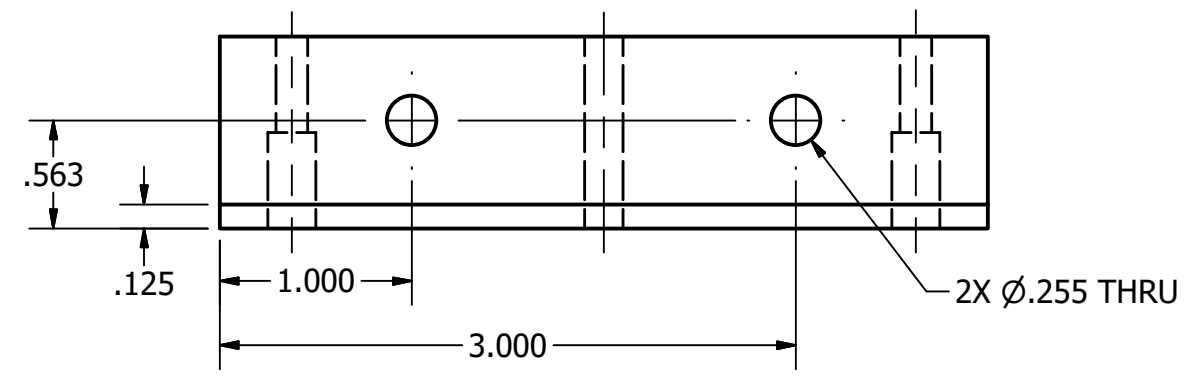

A

A

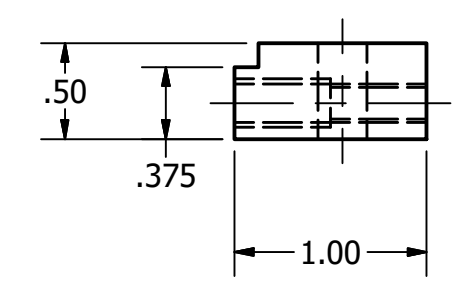
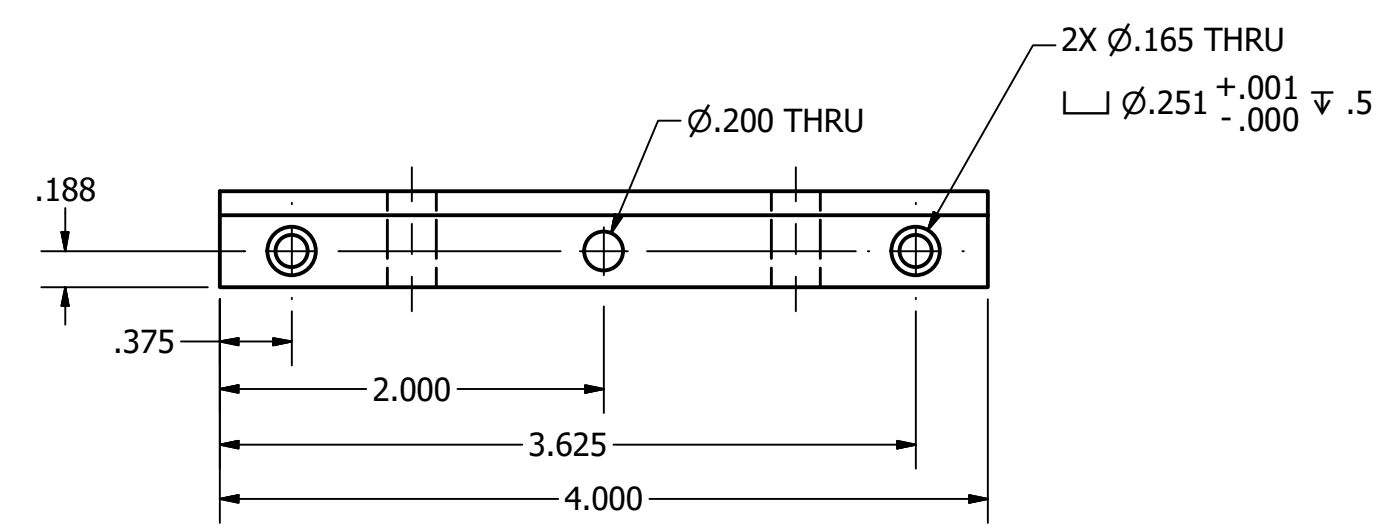

Note: All Dimensions In Inches Unless Otherwise Stated
Break All Sharp Edges

Material: Aluminum, 6061-T6
Quantity: 1

All Tolerances Unless Otherwise Stated

X.X ±0.01
X.XX ±0.005
X.XXX ±0.003

DRAWN		TITLE 001-001 Fixed Jaw		
CHECKED				
QA				
MFG				
APPROVED		SIZE	DWG NO	REV
		B	001-001_FixedJawDrawing	
		SCALE	SHEET 1 OF 1	
		1 : 1		

4 3 2 1

4 3 2 1

B

B

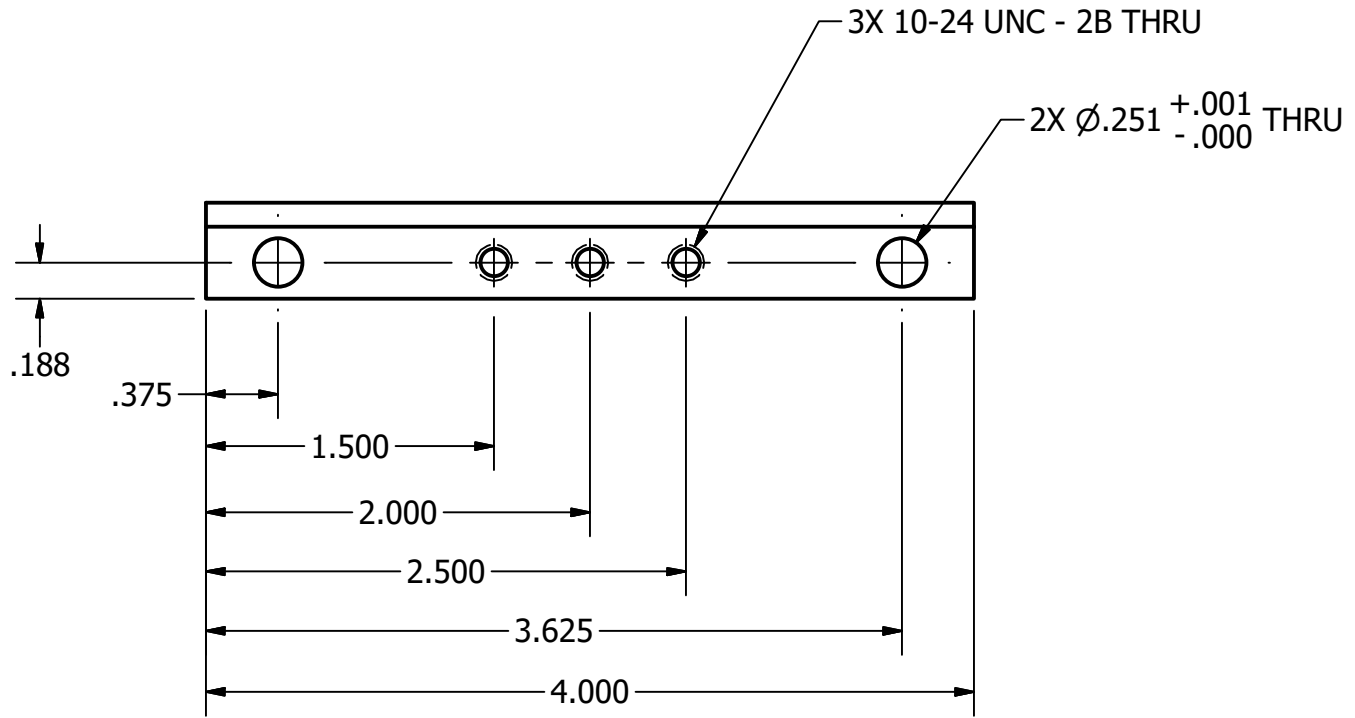
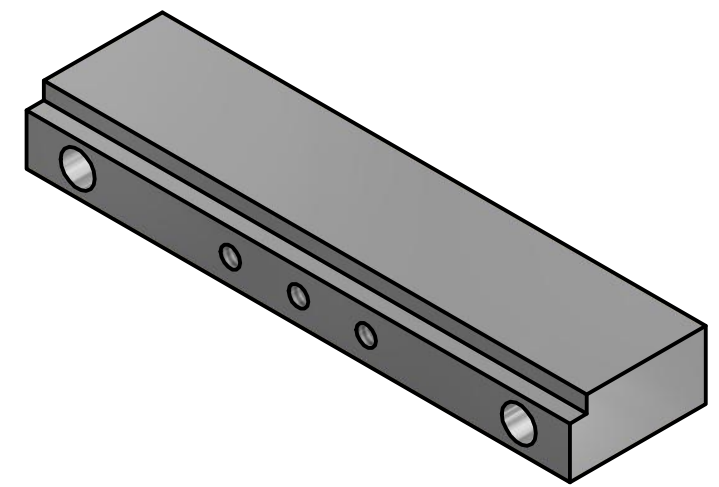
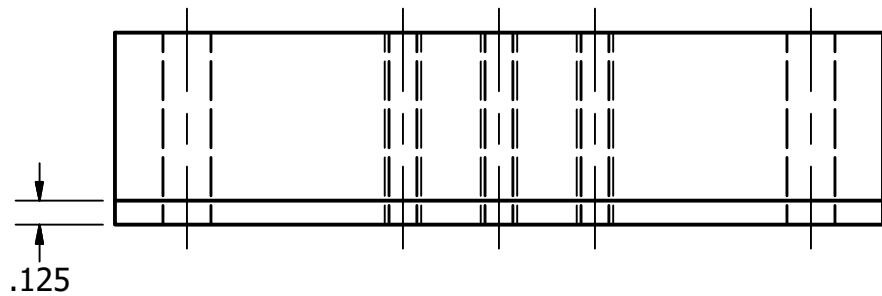

3X 10-24 UNC - 2B THRU

2X \varnothing .251 $\begin{matrix} +.001 \\ -.000 \end{matrix}$ THRU

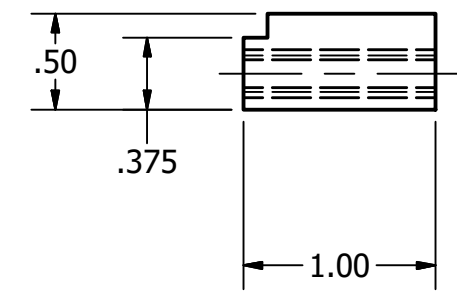

A

A

Note: All Dimensions In Inches Unless Otherwise Stated

Material: Aluminum, 6061-T6

Break All Sharp Edges

Quantity: 1

All Tolerances Unless Otherwise Stated

X.X ±0.01
 X.XX ±0.005
 X.XXX ±0.003

DRAWN		TITLE 001-002 Movable Jaw		
CHECKED				
QA				
MFG				
APPROVED		SIZE	DWG NO	REV
		B	001-002_MovableJawDrawing	
		SCALE	SHEET 1 OF 1	
		1 : 1		

4 3 2 1

4

3

2

1

B

B

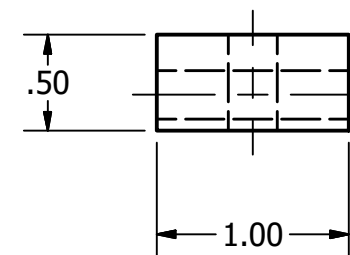
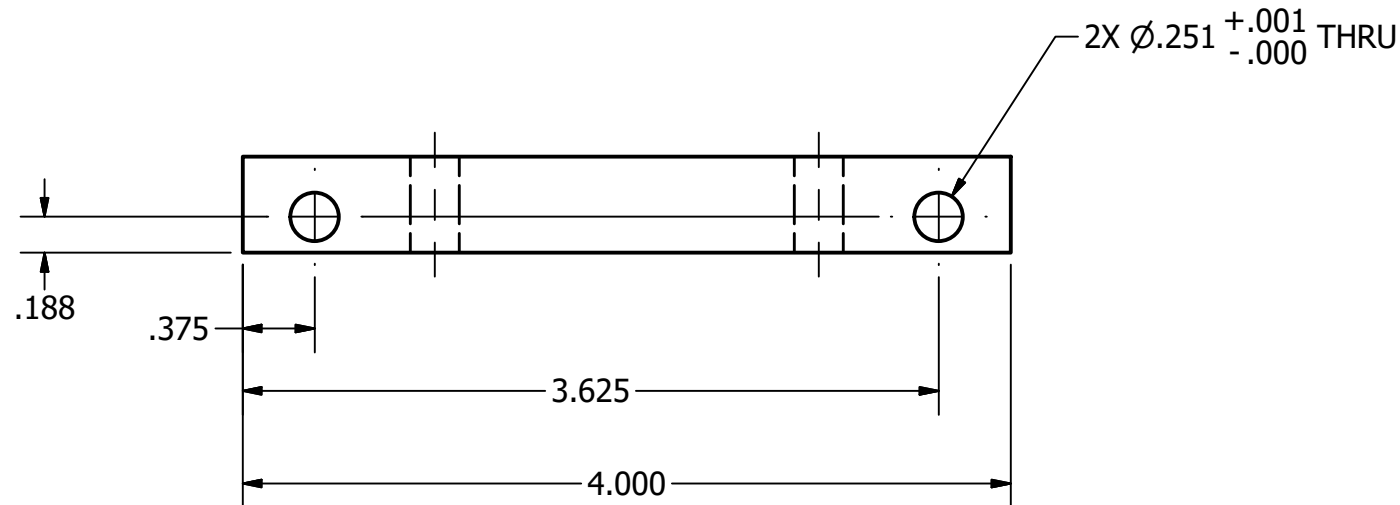
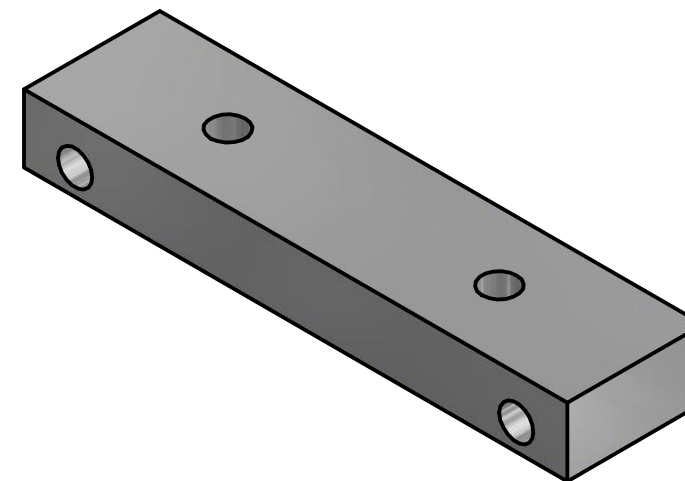
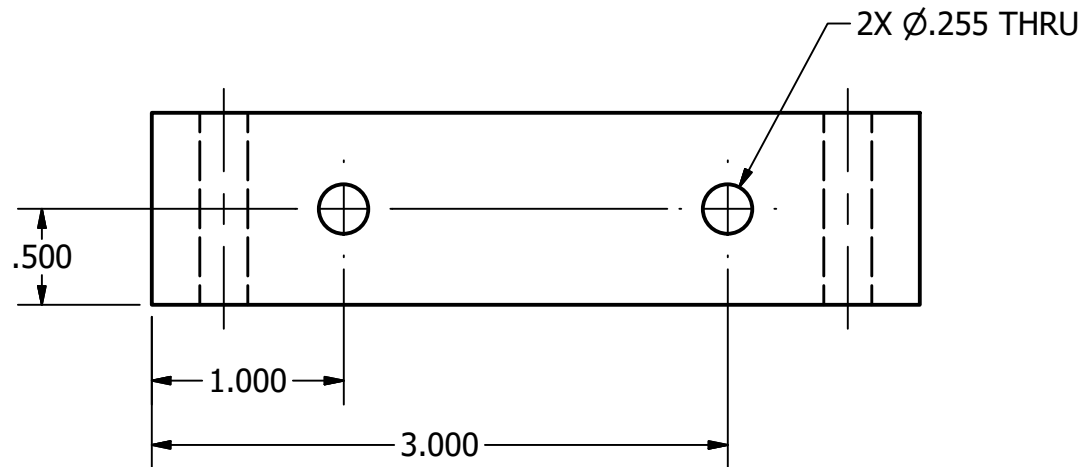

Note: All Dimensions In Inches
Unless Otherwise Stated

Material: Aluminum, 6061-T6

Quantity: 1

Break All Sharp Edges

All Tolerances
Unless Otherwise Stated

X.X ±0.01
X.XX ±0.005
X.XXX ±0.003

DRAWN		TITLE 001-003 Backer Block		
CHECKED				
QA				
MFG				
APPROVED				
		SIZE B	DWG NO 001-003_BackerBlockDrawing	REV
		SCALE 1 : 1	SHEET 1 OF 1	

4

3

2

1

A

A



4 3 2 1

B

B

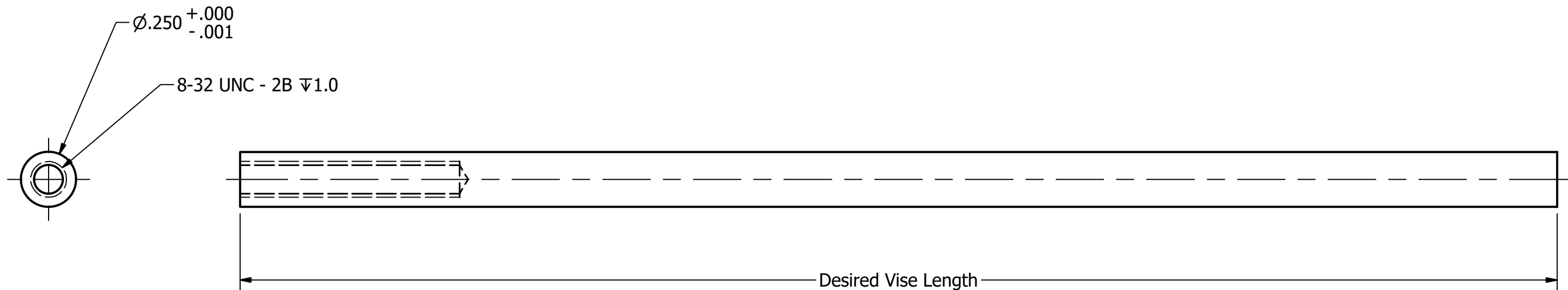

A

A

Note: All Dimensions In Inches Unless Otherwise Stated

Material: Tool Steel Drill Rod, Annealed

Break All Sharp Edges

Quantity: 1

All Tolerances Unless Otherwise Stated

X.X ±0.01
 X.XX ±0.005
 X.XXX ±0.003

DRAWN		TITLE 001-004 Guide Rod		
CHECKED				
QA				
MFG				
APPROVED				
		SIZE B	DWG NO 001-004_GuideRodDrawing	REV
		SCALE 2 : 1	SHEET 1 OF 1	

4 3 2 1

A

A

4 3 2 1

B

B

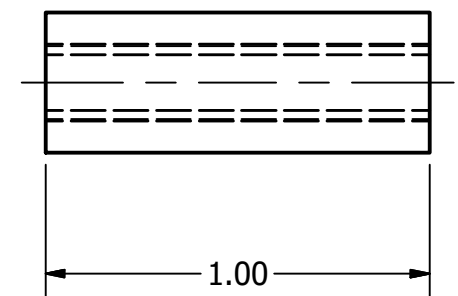
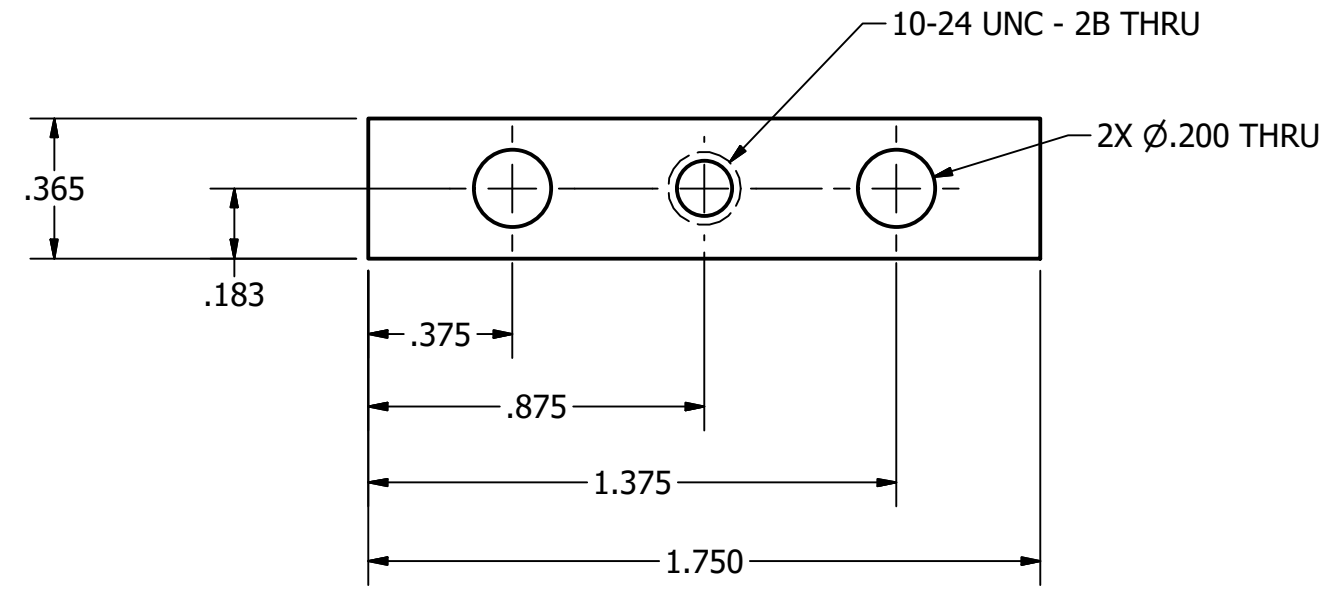
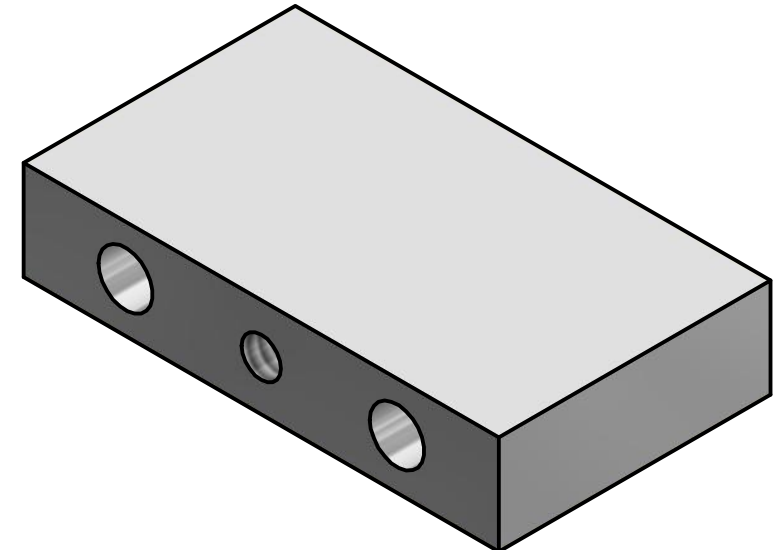
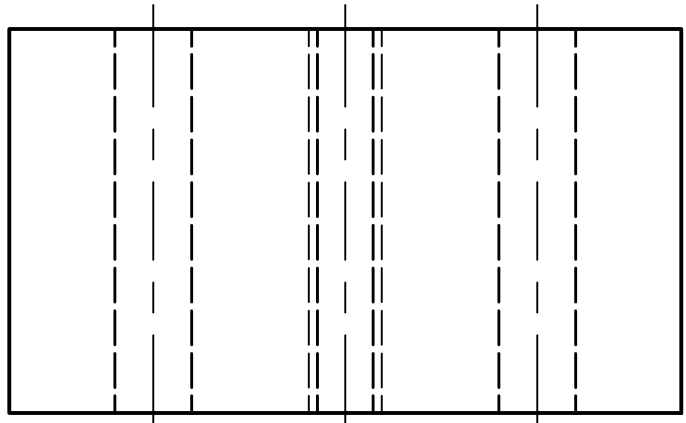

A

A

Note: All Dimensions In Inches Unless Otherwise Stated

Material: Aluminum, 6061-T6

Quantity: 1

Break All Sharp Edges

All Tolerances Unless Otherwise Stated

X.X ±0.01
 X.XX ±0.005
 X.XXX ±0.003

DRAWN		TITLE 001-005 Extender Block		
CHECKED				
QA				
MFG				
APPROVED				
		SIZE B	DWG NO 001-005_ExtenderBlockDrawing	REV
		SCALE 2 : 1	SHEET 1 OF 1	

A

A

4 3 2 1