

Step 3

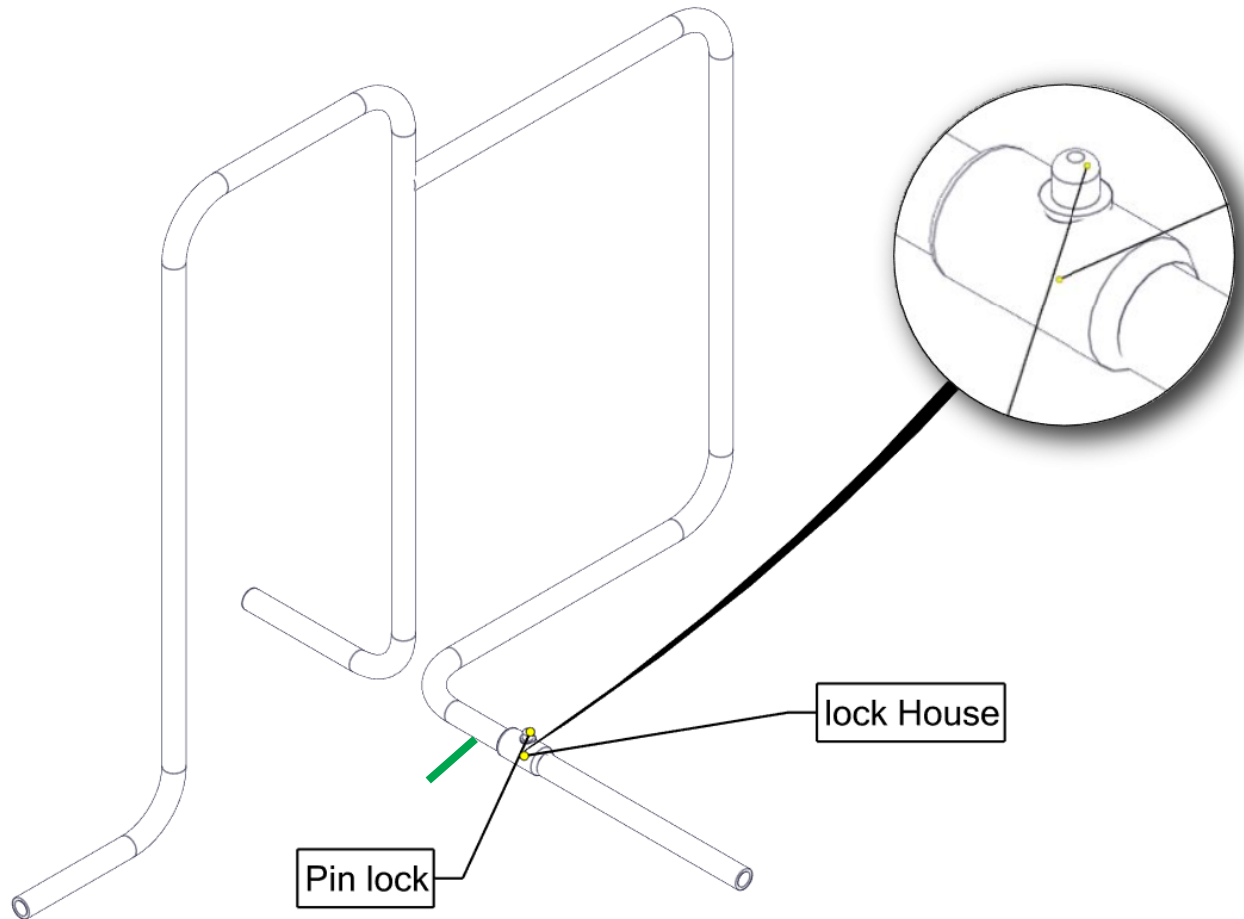

Take a 25 mm diameter pipe and cut a 65 mm long piece from it. Drill a 10 mm diameter hole 23 mm from the marked end.

Then **weld** the 25 mm diameter pipe so that the 22 mm pipe overlaps the inside by a depth of 3 cm. Check that the locking pin passes through both tubes and that the lock is good.