

Main board
<https://makingdevices.com/>
Making Devices

Sheet:
 File: ThermoDeviceLogger.sch

Title: TC Logger Device

Size: A4 Date: 2023-03-21

KiCad E.D.A. kicad 7.0.1

Rev: V1.2b

Id: 1/2

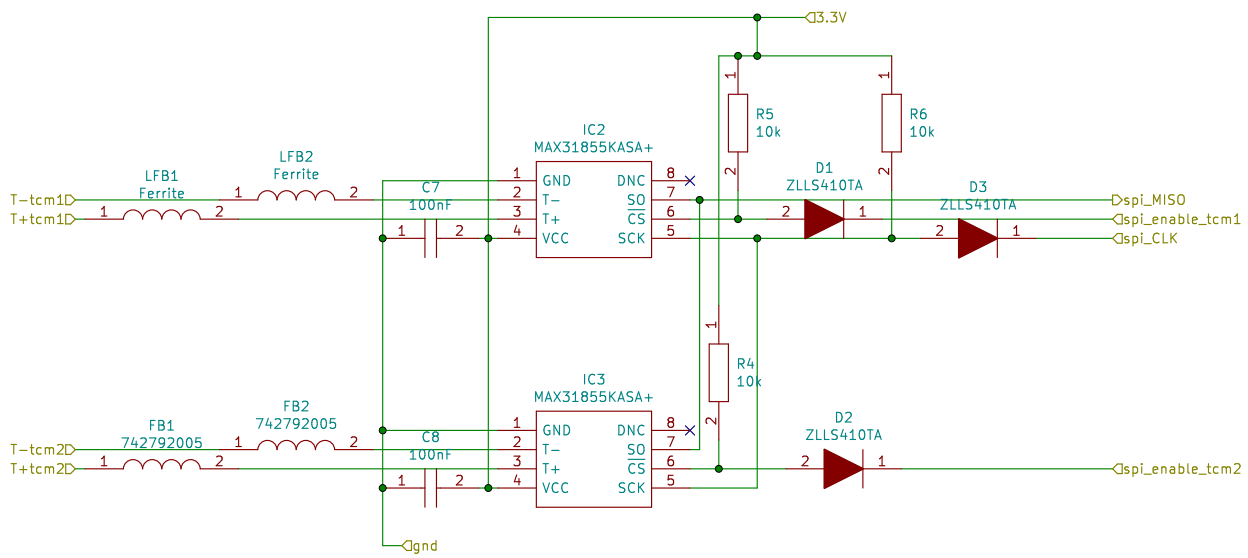

Thermocouple Type-K Reading
<https://makingdevices.com/>

Making Devices

Sheet:
 File: ThermoCouple.sch

Title: Thermo Device Logger

Size: A4 Date: 2021-05-27
 KiCad E.D.A. kicad 7.0.1

Rev: V0.1
 Id: 2/2