

# RearSusLayout1

TrackWidth 22,3cm

## Camber and WheelTravel

Travel measured from center of tirepatch.

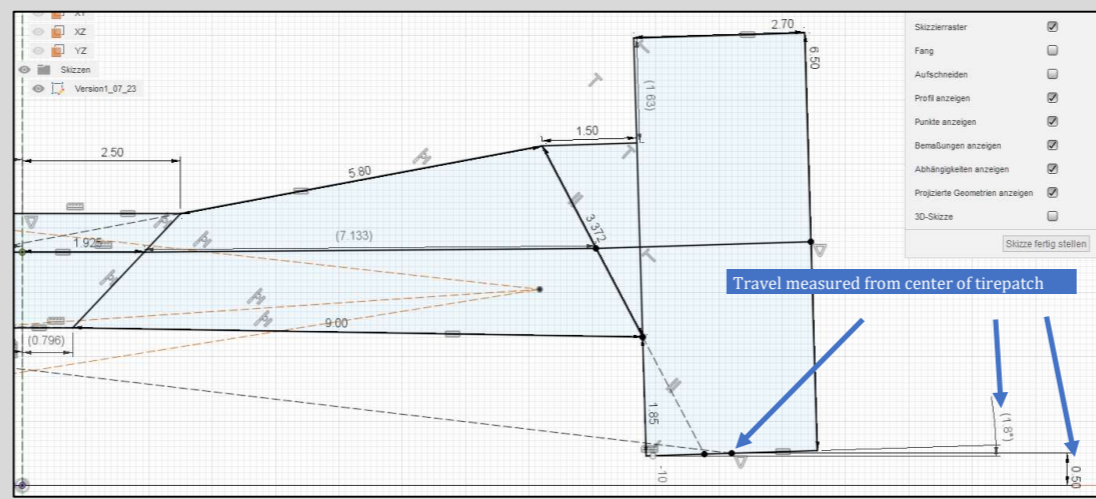
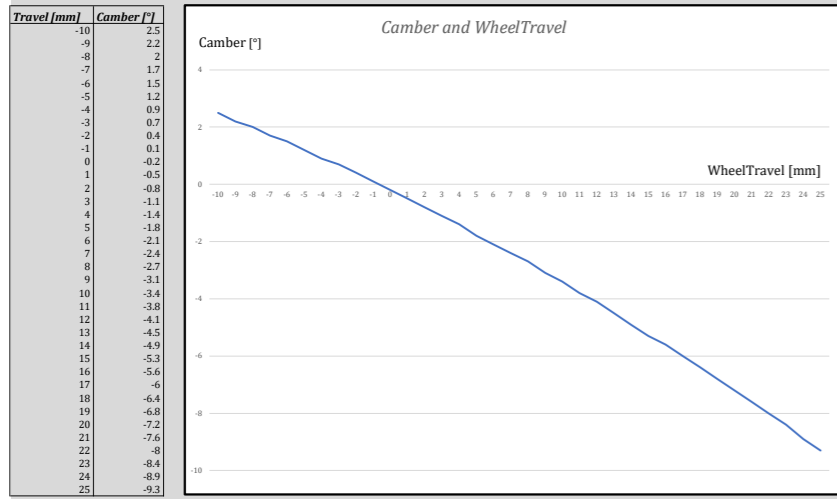

## RollCenter

RollCenter with equal L/R-Travel

Travel [mm]	RollCenterHeigh above Ground [mm]
-10	26.7
-9	25.8
-8	24.9
-7	24
-6	23.1
-5	22.2
-4	21.2
-3	20.3
-2	19.4
-1	18.5
0	17.6
1	16.7
2	15.8
3	14.9
4	14
5	13.1
6	12.2
7	11.3
8	10.4
9	9.5
10	8.5
11	7.6
12	6.7
13	5.8
14	4.9
15	4
16	3.1
17	2.2
18	1.3
19	0.4
20	-0.5
21	-1.4
22	-2.3
23	-3.2
24	-4.1
25	-5

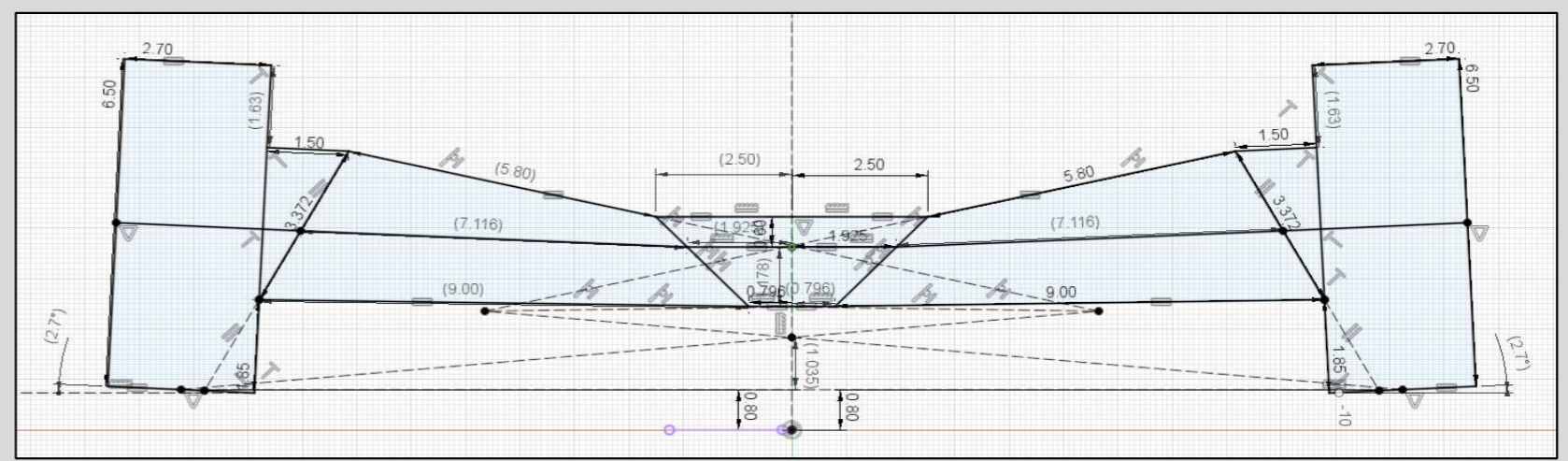
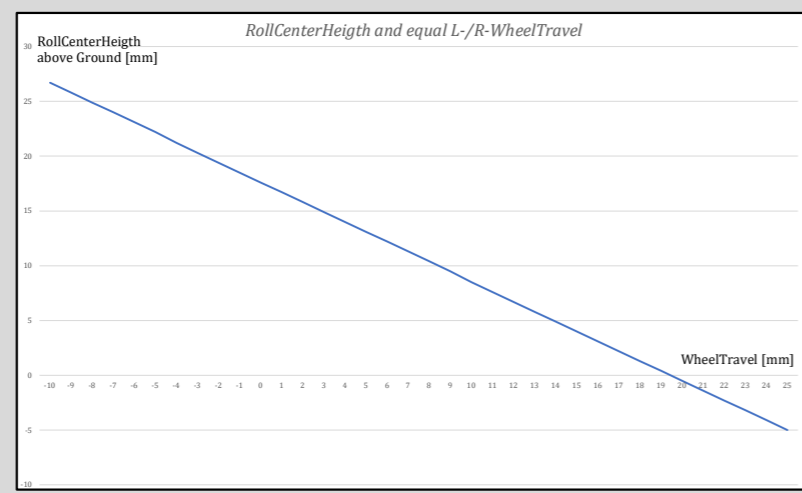

RollCenter with opposite, "equal" L/R-Travel

Travel [mm]	RollCenterHeigh above Ground [mm]	RollCenterTravel L/R [mm]
1	17.6	0.7
2	17.6	1.5
3	17.6	2.2
4	17.6	3
5	17.6	3.7
6	17.6	4.4
7	17.6	5.2
8	17.7	5.9
9	17.7	6.6
10	17.7	7.4

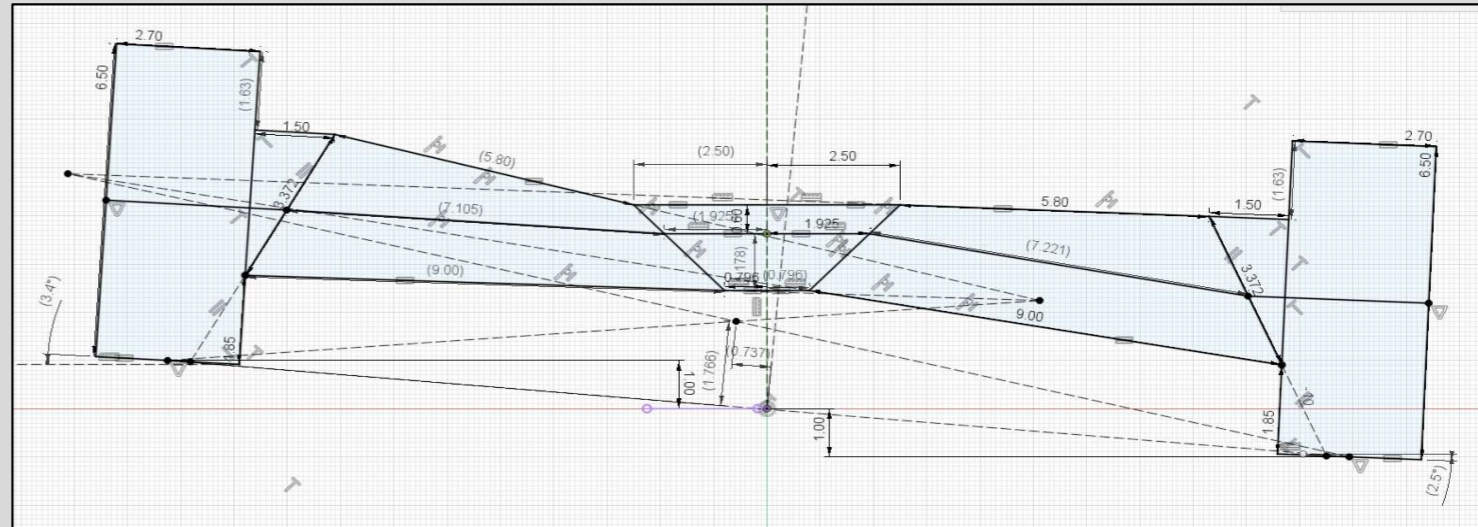
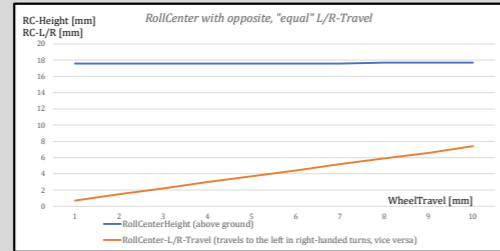

RollCenter with LTravel = -2\*RTravel

Travel [mm]	RollCenterHeigh above Ground [mm]	RollCenterTravel L/R [mm]
0	17.6	0
2	17.2	1.1
4	16.7	2.3
6	16.3	3.6
8	15.8	4.9
10	15.4	6.3
12	14.9	7.7
14	14.5	9.2
16	14	10.8
18	13.6	12.5
20	13.1	14.3

