

Practical Commutation Circuits

In this tutorial, we will learn about SCR Turn OFF Methods By Practical Circuits. There are several ways to properly implement the SCR Turn OFF methods like Natural, Forced. In Forced Commutation, there are again several sub-categories like Class A, B, C, D, E. We will learn about all these different methods to properly turn OFF an SCR, different classes of Commutation and also the Dynamic Turn OFF Characteristics of SCR.

Forced Commutation

In case of DC circuits, there is no natural current zero to turn OFF the SCR. In such circuits, forward current must be forced to zero with an external circuit (known as Commutating Circuit) to commutate the SCR. Hence the name, Forced Commutation.

This commutating circuit consist of components like inductors and capacitors and they are called Commutating Components. These commutating components cause to apply a reverse voltage across the SCR that immediately bring the current in the SCR to zero.

Depending on the process for achieving zero current in the SCR and the arrangement of the commutating components, Forced Commutation is classified into different types. They are:

- Class A – Self Commutation by Resonating the Load
- Class B – Self Commutation by Resonating the Load
- Class C – Complementary Commutation
- Class D – Auxiliary Commutation
- Class E – Pulse Commutation

such as class A, B, C, D, and E. This commutation is mainly used in chopper and inverter circuits.

Class A Commutation

This is also known as Self Commutation by Resonating the Load or simply the Resonant Commutation. In this commutation, the source of commutation voltage is in the load. The commutating components are L and C and the Capacitor can be connected either in parallel or in series with the load resistance R_L as shown below.

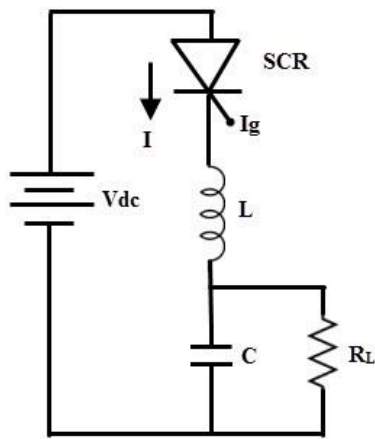

Load in parallel with capacitor

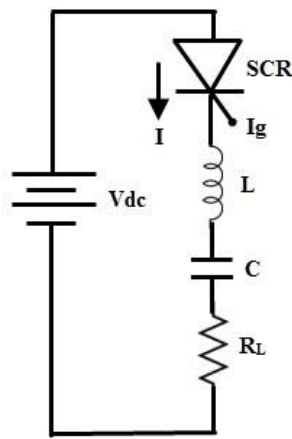

Load in series with capacitor

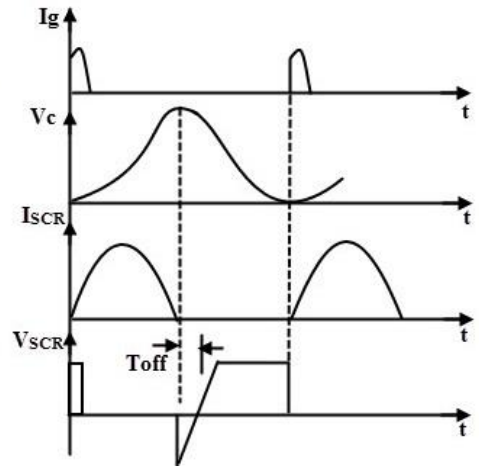

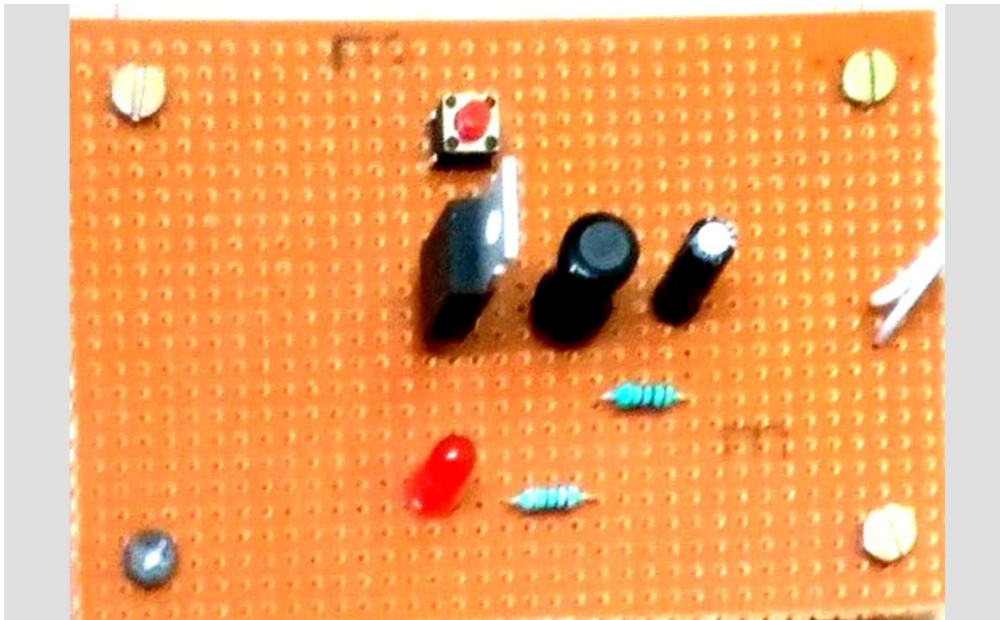
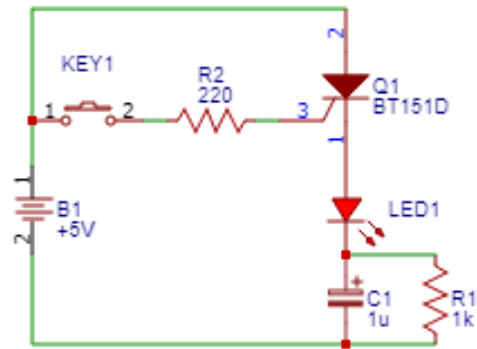

Practical circuit of Series Class A Commutation Circuit

Circuit diagram of Class A Commutation

Class B Commutation

This is also a self commutation circuit in which commutation of SCR is achieved by a resonating LC Circuit. But the main difference between Class A and Class B Commutation is that the LC resonant circuit is connected across the SCR but not in series with the load as in case of Class A Commutation. As a result, the commutating circuit and the L and C components in it doesn't carry the load current.

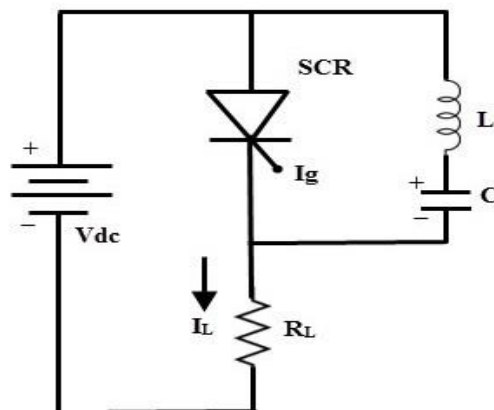

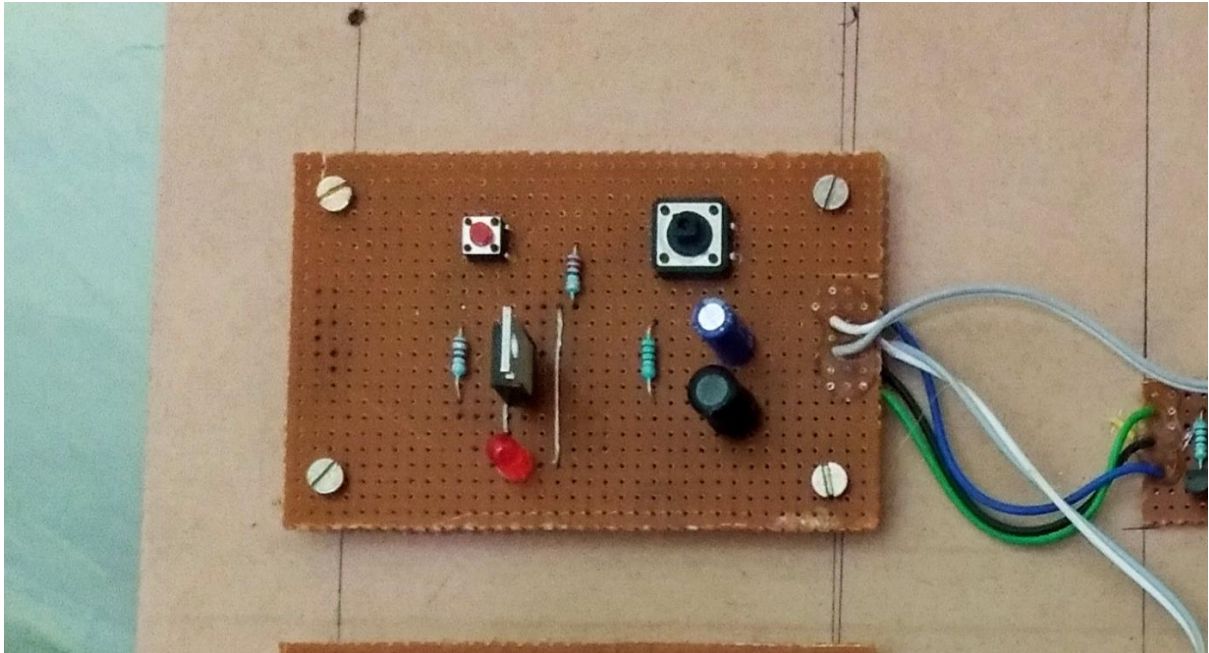

Practical Circuit of Class B Commutation

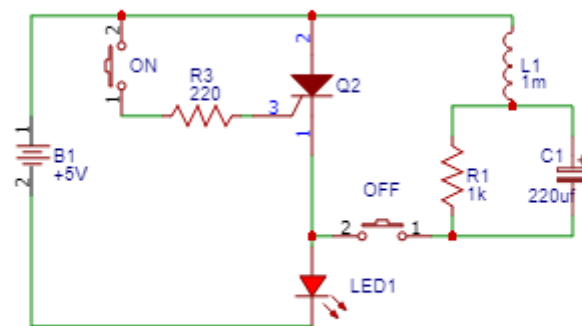

Circuit diagram of Class B Commutation

Class C Commutation

In this commutation method, the main SCR (which is to be commutated) is connected in series with the load and an additional or complementary SCR is connected in parallel with the main SCR. Hence, this method is also called as Complementary Commutation.

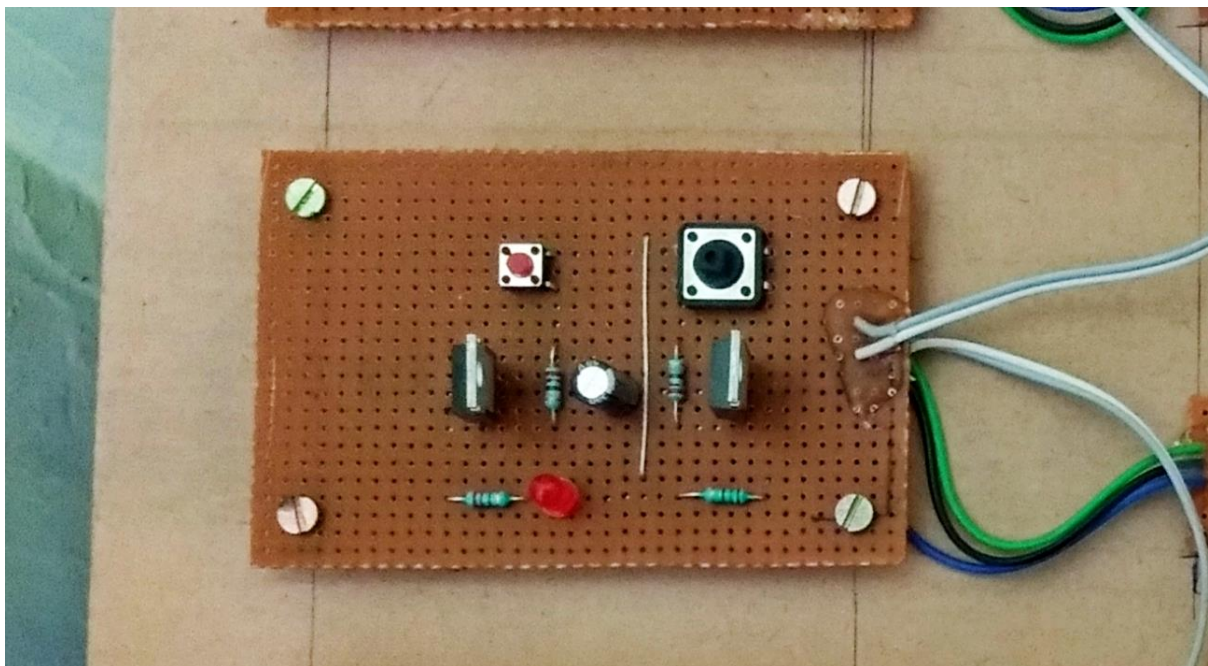
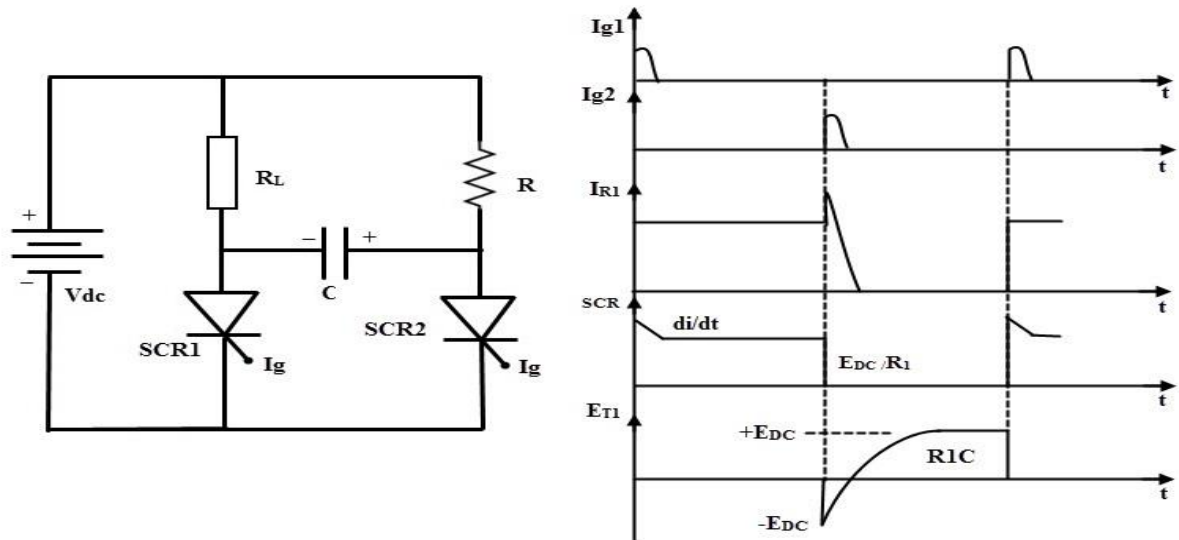

Practical Circuit of Class C Commutation

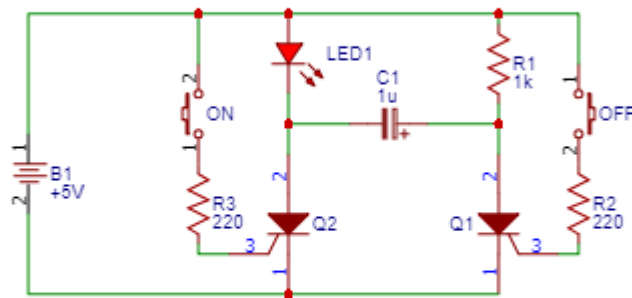

Circuit diagram of Class C Commutation

Class D Commutation

This is also called as auxiliary commutation because it uses an auxiliary SCR to switch the charged capacitor. In this, the main SCR is commutated by the auxiliary SCR. The main SCR with load resistance forms the power circuit while the diode D, inductor L and SCR2 forms the commutation circuit.

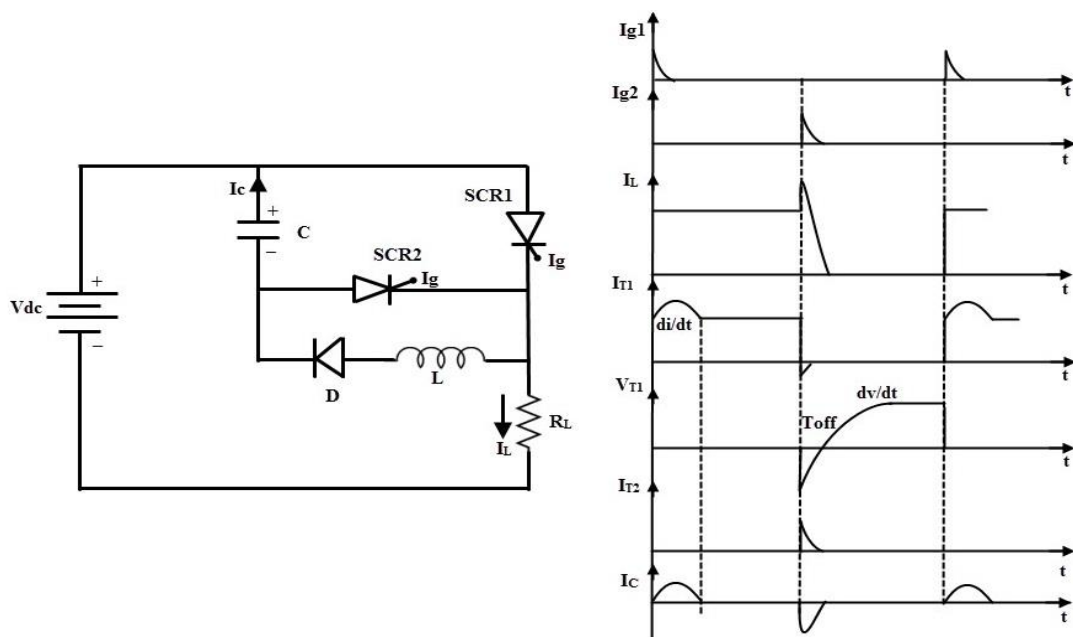

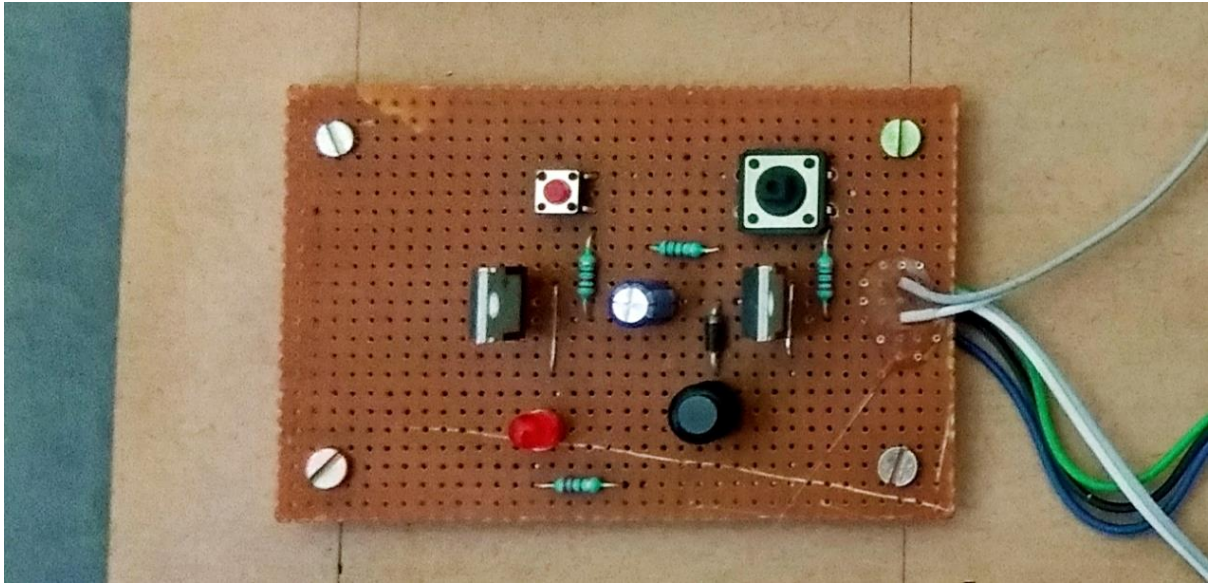

Practical Circuit of Class D Commutation

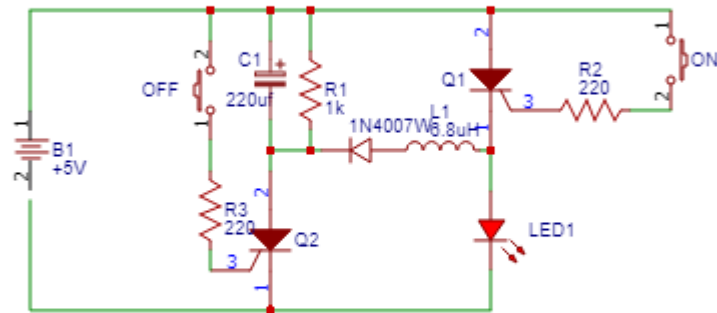

Circuit diagram of Class D Commutation

Class E Commutation

This type of Commutation is also known as External Pulse Commutation. In this, an external pulse source is used to produce the reverse voltage across the SCR. The circuit below shows the Class E commutation circuit, which uses a pulse transformer to produce the commutating pulse. The transformer is designed with tight coupling between the primary and secondary and also there is a small air gap in the transformer so that it doesn't get saturated when the pulse is applied.

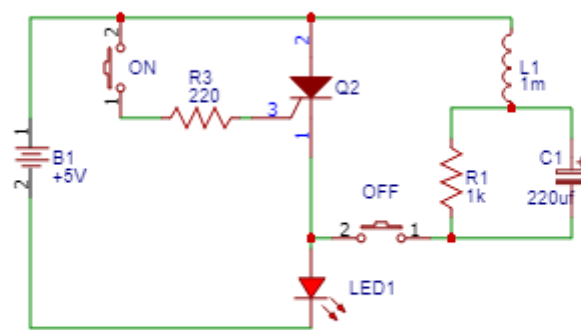
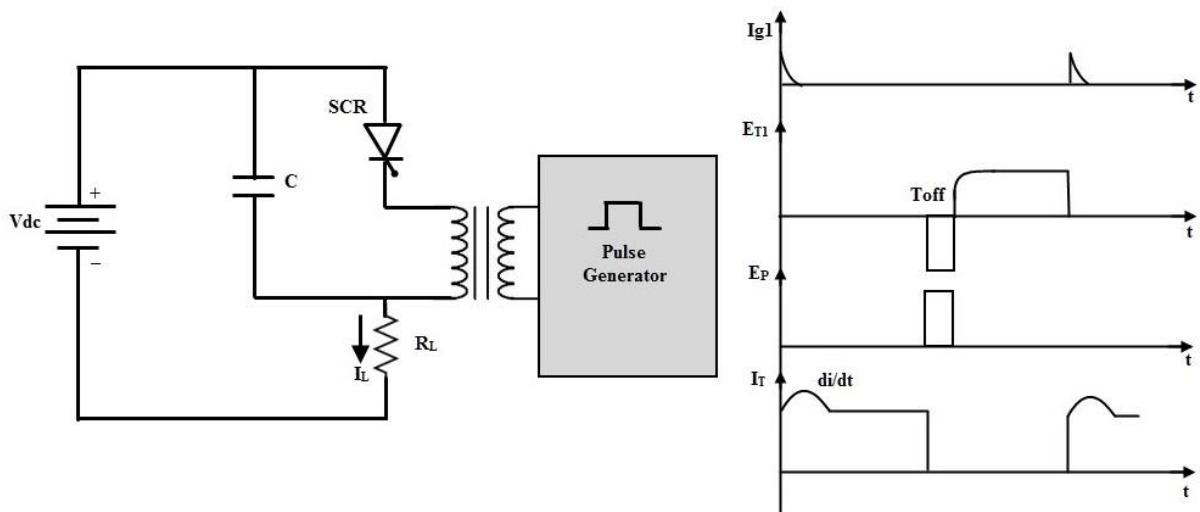

Circuit diagram of Class E Commutation

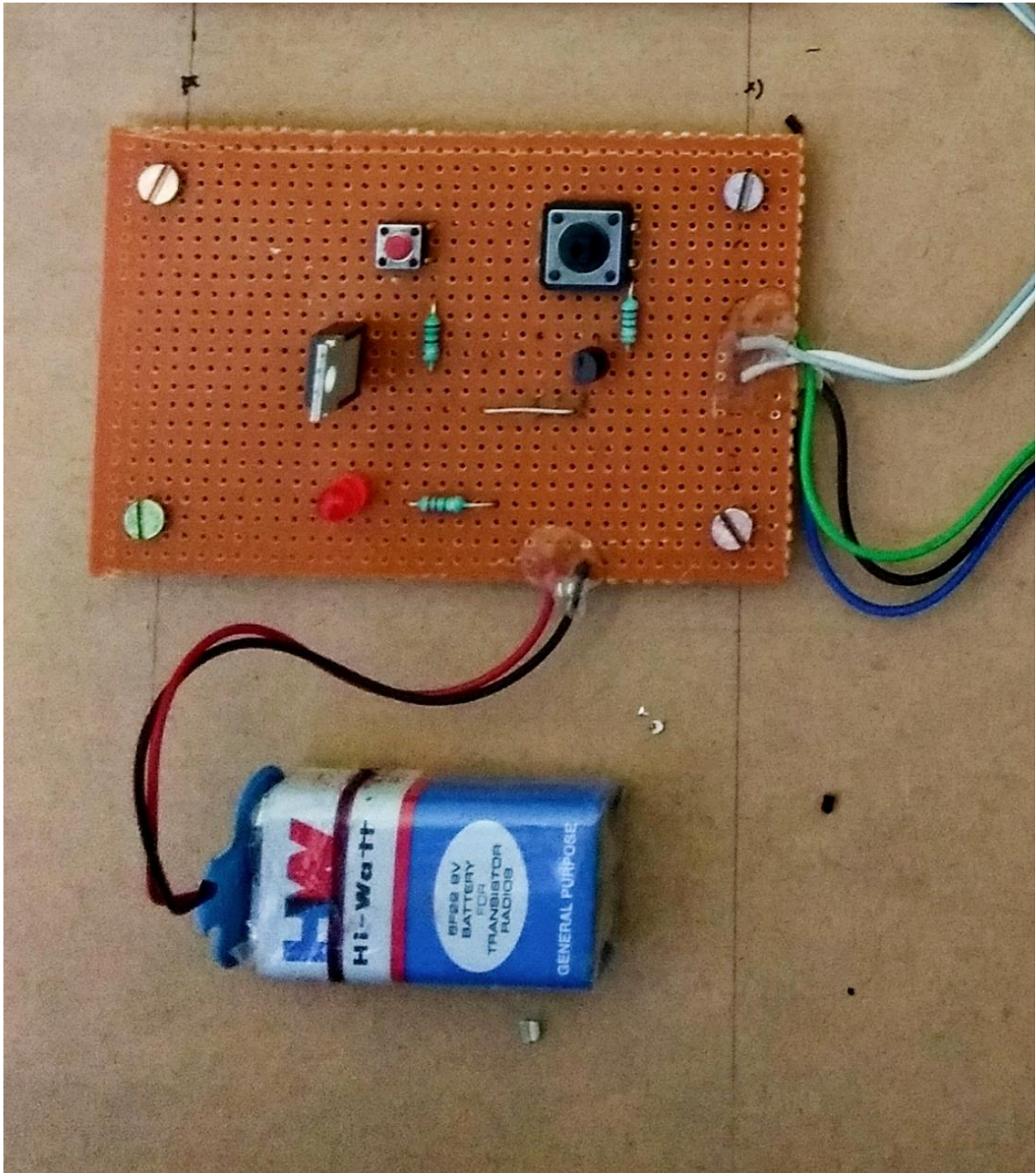

Practical Circuit of Class E Commutation

Create BY AK

