

# Assembly View

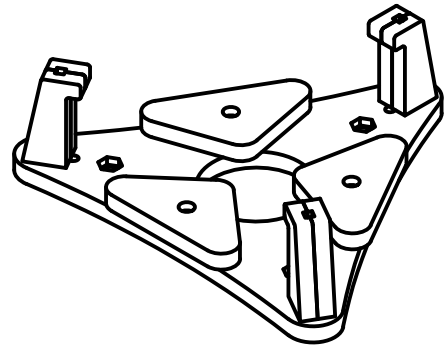

Mirror support points calculated using GUI PLOP.

Collimation screw holes sized for  $\frac{3}{8}$ " bolts

Mirror supports pivot on press-fit spherical bearings, secured with  $\frac{1}{4}$ " allen head cap screws.

Mirror edge supports are done in two pieces, glued together, and secured with  $\frac{1}{4}$ " allen head cap screws, washers, and ny-loc nuts.

Center hole for air flow if using mirror cooling fan.

