

SCALE 1:10

9	BEARING 51120-2RS	01		51120-2RS	-	- g
8	M3x10 BOLT	14		DIN912	-	- g
7	QUICK_CHANGE	01	OSH.00_07.00_0		-	43 g
6	J5	01	OSH.00_06.00_0		-	512 g
5	J4	01	OSH.00_05.00_0		-	76 g
4	J3	01	OSH.00_04.00_0		-	1163 g
3	J2	01	OSH.00_03.00_0		-	1124 g
2	J1	01	OSH.00_02.00_0		-	1785 g
1	J0	01	OSH.00_01.00_0		-	923 g
Marca	Descripció	Quant.	Nº Plànol / Codi	Norma / Referència	Material	Pes
Cognom, Nom			Data		ELISAVA Escola Superior de Disseny i Enginyeria de Barcelona GRAU EN ENGINYERIA EN DISSENY INDUSTRIAL	
Autor	Latorre, Alex / Pèlach, Mar		05/05/2022			
Tutor	Chacón, Jonathan / Mestres, Francesc		05/05/2022		Nº Plànol: OSH.00_00.00_0	
Nom Projecte: MOTUS		Material: -				
Escala 1:5 Pes 6000 g		Descripció: MOTUS		Tractament / Acabat: -		

A-A (1:2)

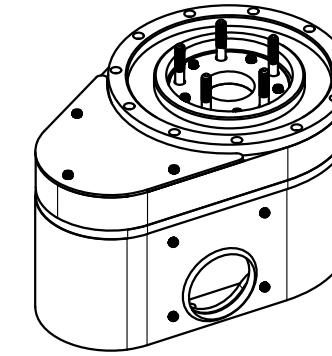
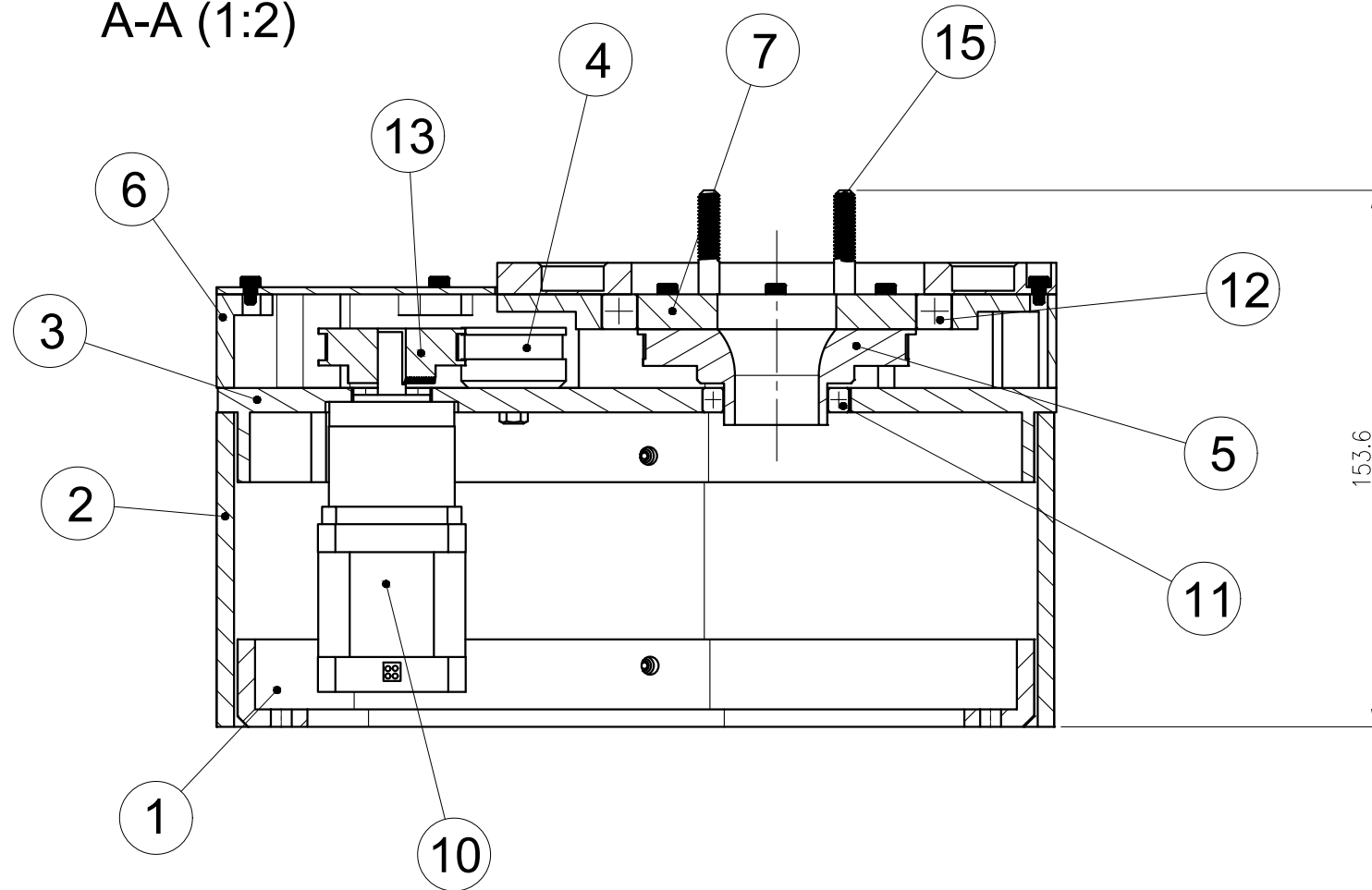

SCALE 1:5

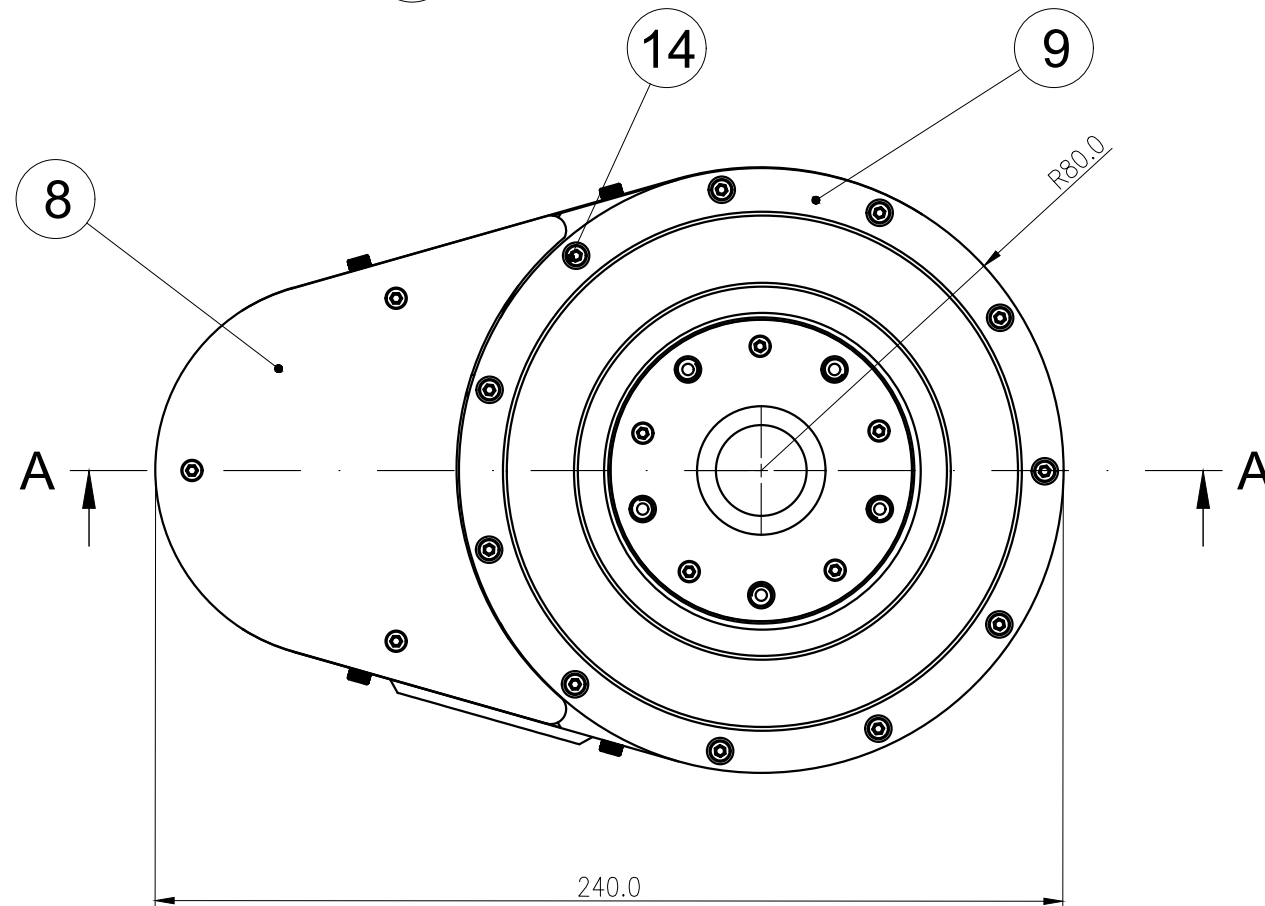

15	M6x35 BOLT	05		DIN7991		- g
14	M3x10 BOLT	36		DIN912		- g
13	60T GT2 PULLEY	01		B086QHF7Y2		- g
12	BEARING 6816-2RS	01		6816-2RS		- g
11	BEARING 6810ZZ-Z2	01		6810ZZ-Z2		- g
10	STEPPER MOTOR 17HS19-1684S-PG19	01		17HS19-1684S-PG19		420 g
9	J0_TOP	01	OSH.01_00.08_0		PLA	43 g
8	J0_MOTORLID	01	OSH.01_00.07_0		PLA	19 g
7	J0_PULLEYTOP	01	OSH.01_00.06_0		PLA	12 g
6	J0_BASE	01	OSH.01_00.05_0		PLA	81 g
5	J0_120T GT2 PULLEY	01	OSH.01_00.04_0		80-20 PLA/CF	20 g
4	TENSOR_ASSEMBLY	01	OSH.01_01.00_0		PLA	7 g
3	J0_BOTTOM	01	OSH.01_00.03_0		PLA	106 g
2	J0_BOTTOMCOVER	01	OSH.01_00.02_0		PLA	86 g
1	J0_INSERT	01	OSH.01_00.01_0		PLA	57 g
Marca	Descripció	Quant.	Nº Plànol / Codi	Norma / Referència	Material	Pes

Cognom, Nom		Data	ELISAVA Escola Superior de Disseny i Enginyeria de Barcelona
Autor	Latorre, Alex	05/05/2022	
Tutor		Chacón, Jonathan / Mestres, Francesc	GRAU EN ENGINYERIA EN DISSENY INDUSTRIAL
Nom Projecte:		MOTUS	Nº Plànol: OSH.01_00.00_0
Descripció:		J0	Material: -
Escala 1:2			Tractament / Acabat: -
Pes 923 g			

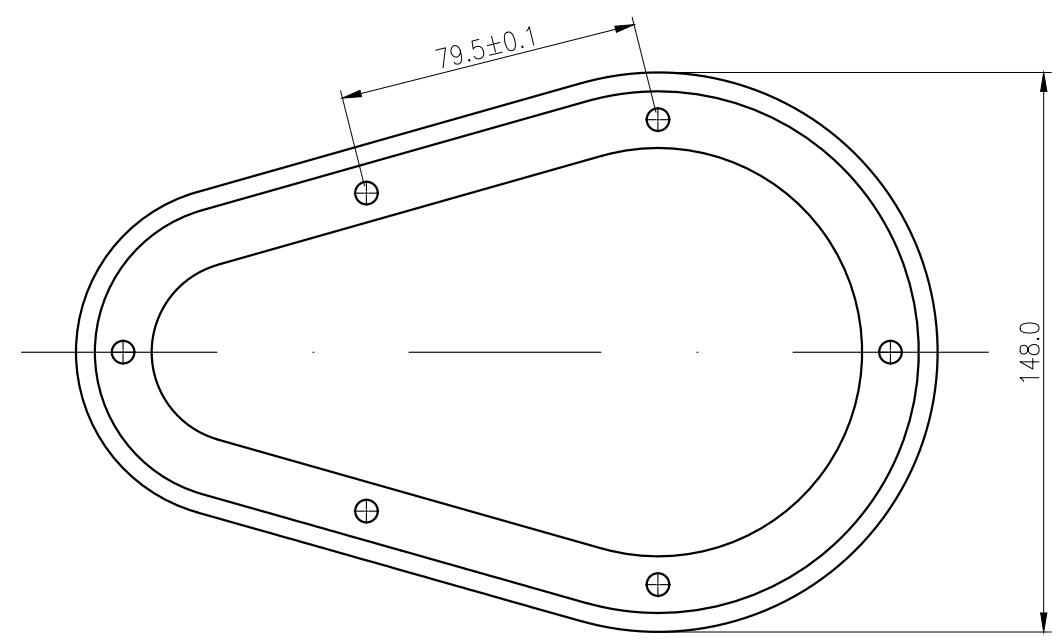
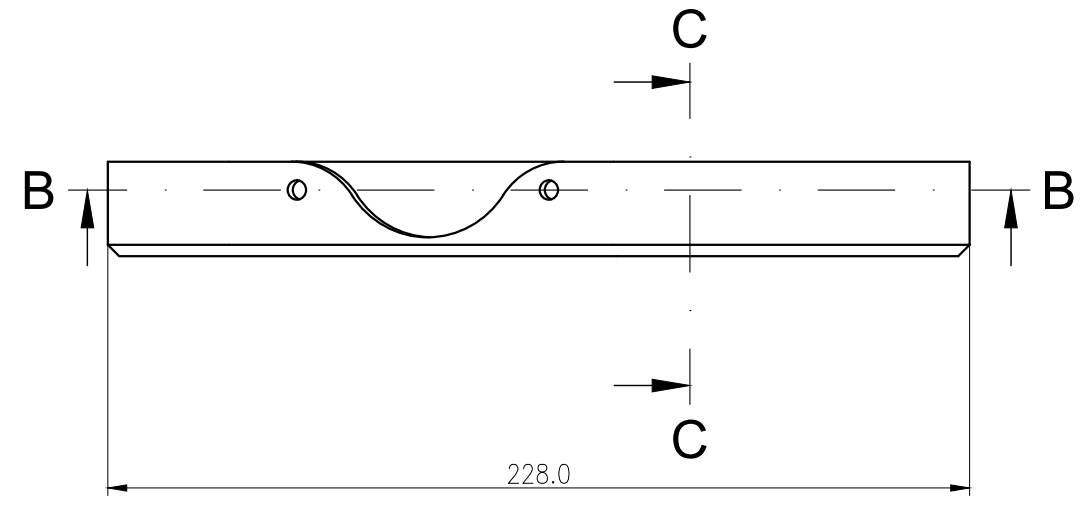
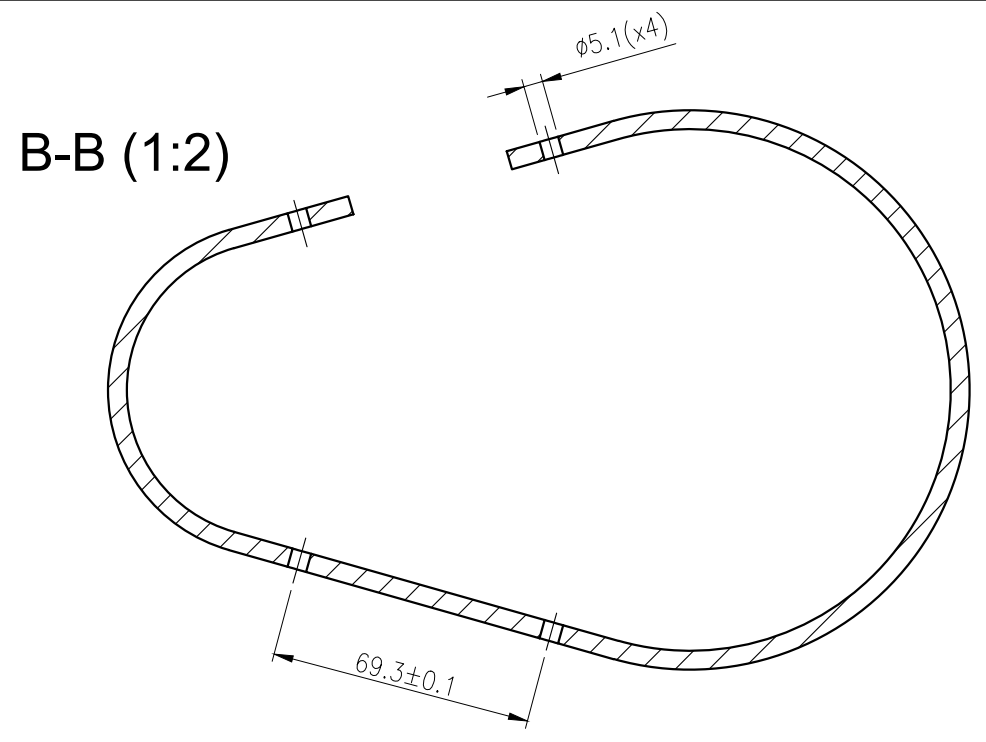

PRINT ORIENTATION

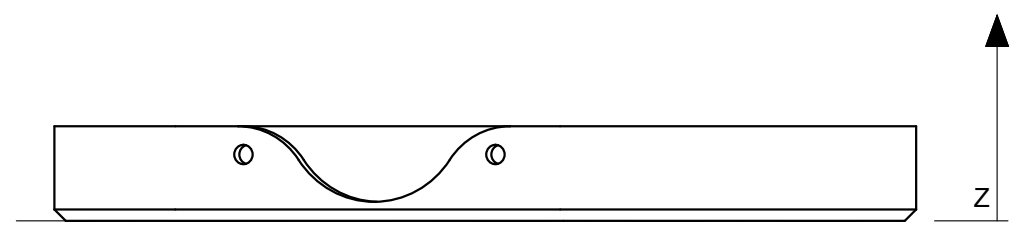

C-C (1:2)

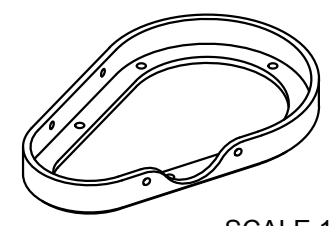
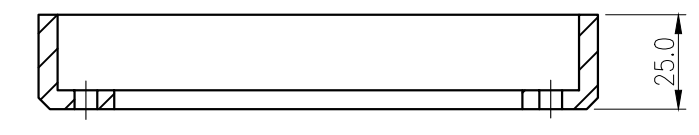

SCALE 1:5

Printing Parameters	
Material	PLA
Extruder Diameter	0.4 mm
Layer Height	0.2 mm
Shell Thickness	1 mm
Infill	20%
Extruder Temperature	220 °C
Bed Temperature	60 °C
Supports	N

Cognom, Nom			Data		
Autor	Latorre, Alex		05/05/2022		
Tutor	Chacón, Jonathan / Mestres, Francesc		05/05/2022		
Escala 1:2 Pes 57 g	Nom Projecte:	MOTUS		Nº Plànol:	OSH.01_00.01_0
	Descripció:	J0_INSERT		Material:	PLA
				Tractament / Acabat:	-

ELISAVA Escola Superior de Disseny i Enginyeria de Barcelona

GRAU EN ENGINYERIA EN DISSENY INDUSTRIAL

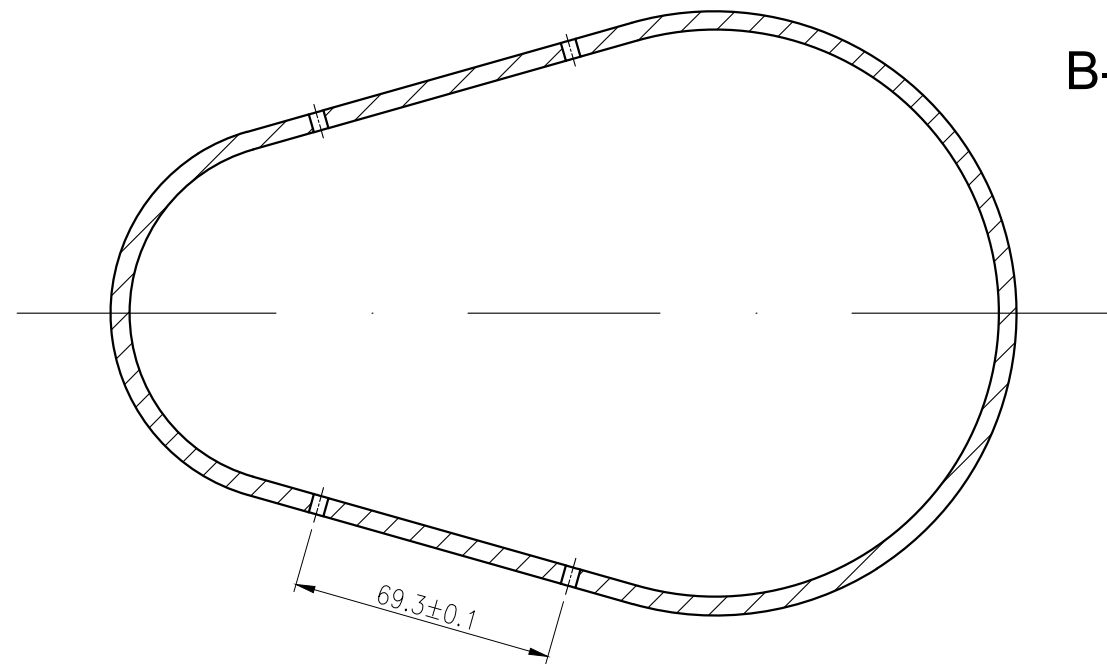

B-B (1:2)

PRINT ORIENTATION

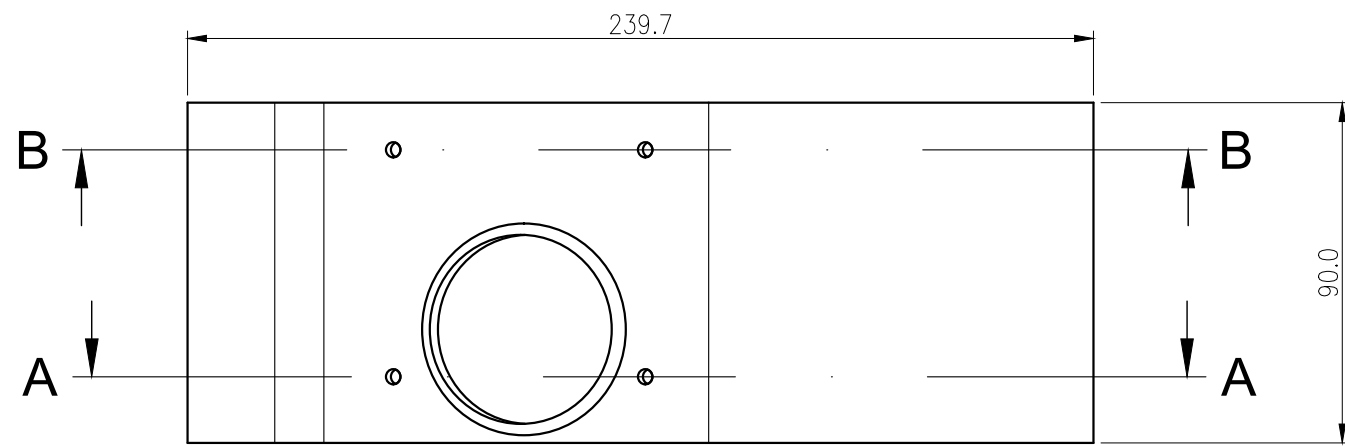
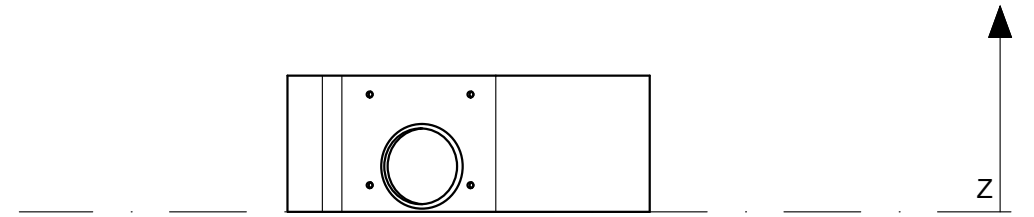

A-A (1:2)

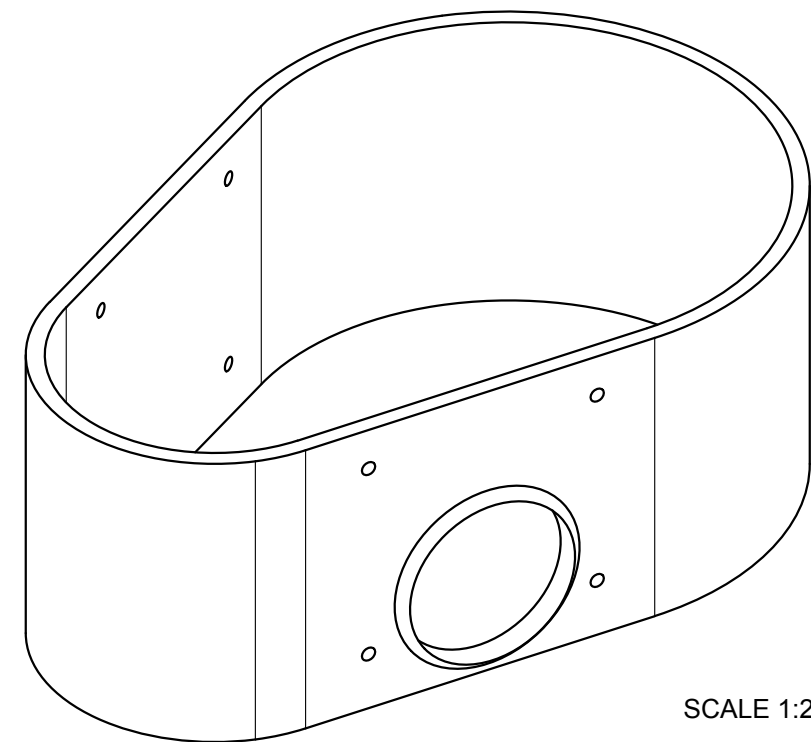

SCALE 1:2

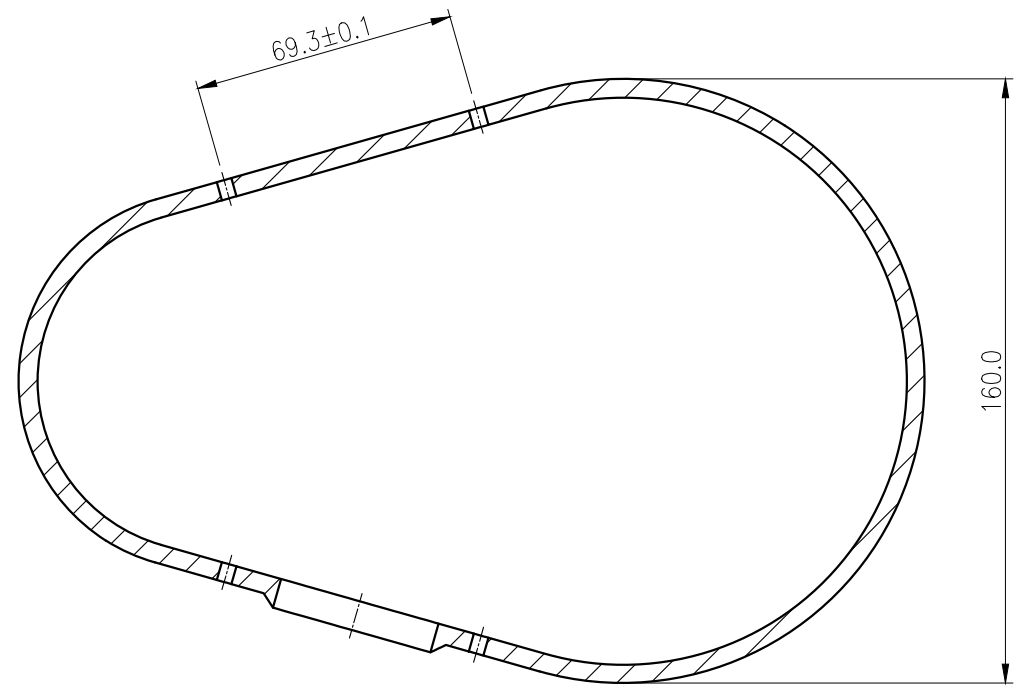

Printing Parameters	
Material	PLA
Extruder Diameter	0.4 mm
Layer Height	0.2 mm
Shell Thickness	1 mm
Infill	20%
Extruder Temperature	220 °C
Bed Temperature	60 °C
Supports	N

	Cognom, Nom	Data	ELISAVA Escola Superior de Disseny i Enginyeria de Barcelona GRAU EN ENGINYERIA EN DISSENY INDUSTRIAL
Autor	Latorre, Alex	05/05/2022	
Tutor	Chacón, Jonathan / Mestres, Francesc	05/05/2022	Nº Plànol: OSH.01_00.02_0
	Nom Projecte:	MOTUS	
Escala 1:2 Pes 86 g	Descripció:	J0_BOTTOMCOVER	
	Material:	PLA	
	Tractament / Acabat:	-	

C-C (1:2)

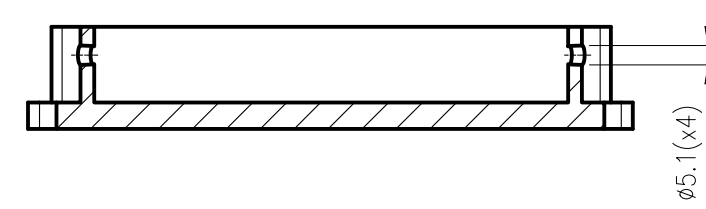

B-B (1:2)

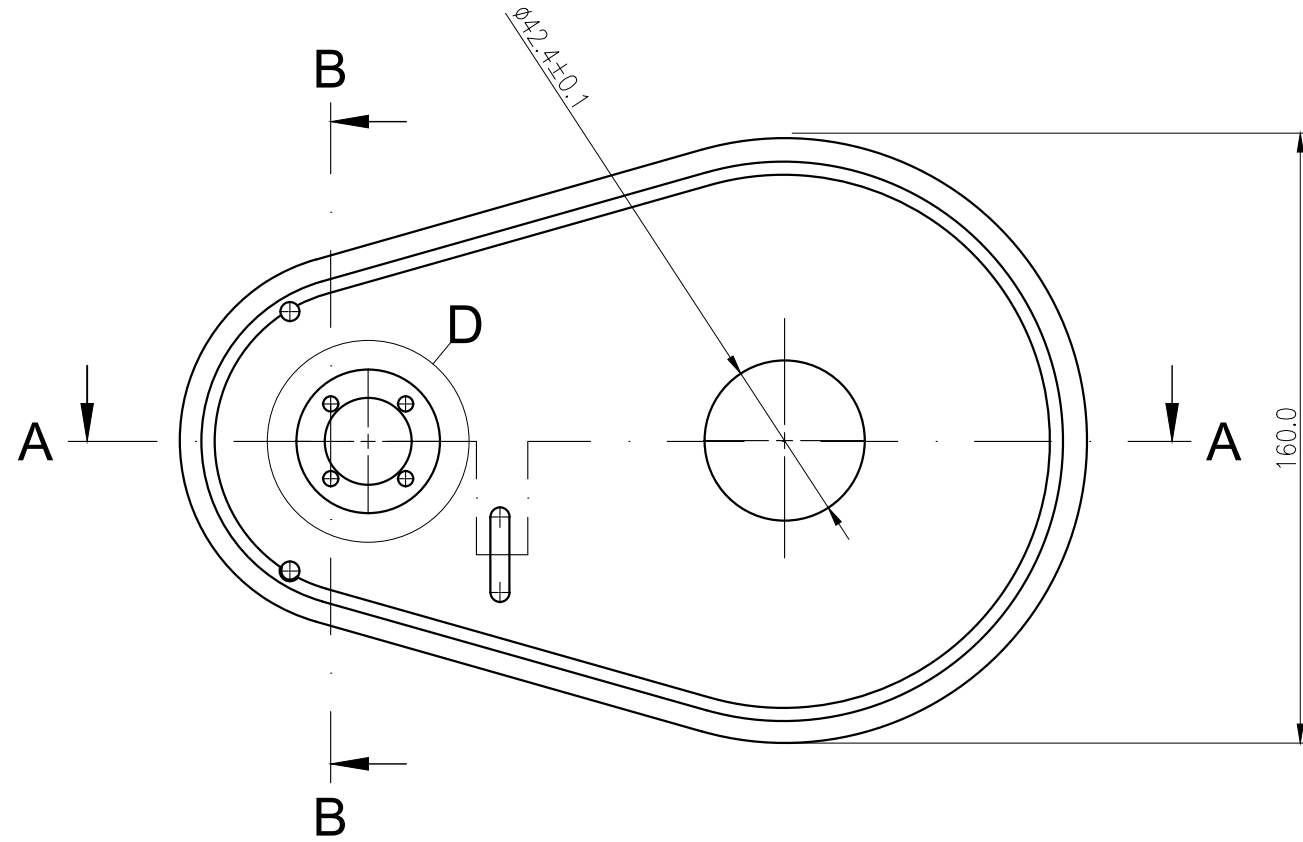
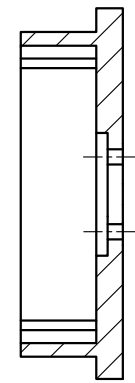

A-A (1:2)

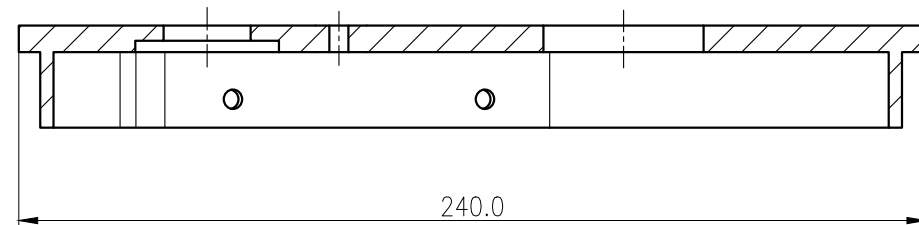

D (1:2)

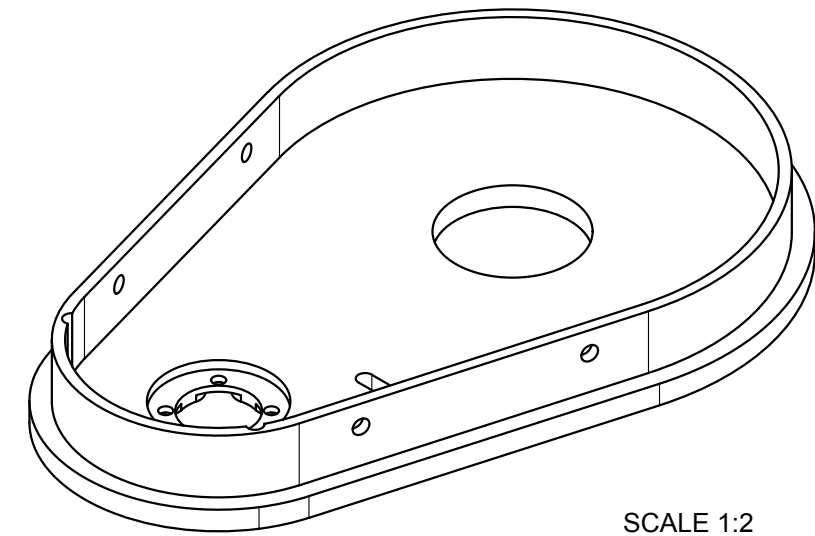
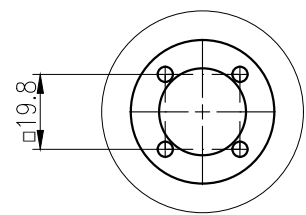

SCALE 1:2

Printing Parameters	
Material	PLA
Extruder Diameter	0.4 mm
Layer Height	0.2 mm
Shell Thickness	1 mm
Infill	20%
Extruder Temperature	220 °C
Bed Temperature	60 °C
Supports	N

PRINT ORIENTATION

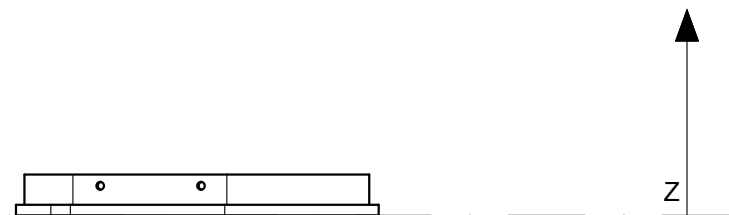

	Cognom, Nom	Data	ELISAVA Escola Superior de Disseny i Enginyeria de Barcelona
Autor	Latorre, Alex	05/05/2022	
Tutor	Chacón, Jonathan / Mestres, Francesc	05/05/2022	GRAU EN ENGINYERIA EN DISSENY INDUSTRIAL
	Nom Projecte:	MOTUS	Nº Plànol: OSH.01_00.03_0
	Descripció:	J0_BOTTOM	Material: PLA
Escala 1:2			Tractament / Acabat: -
Pes 106 g			

A-A (1:1)

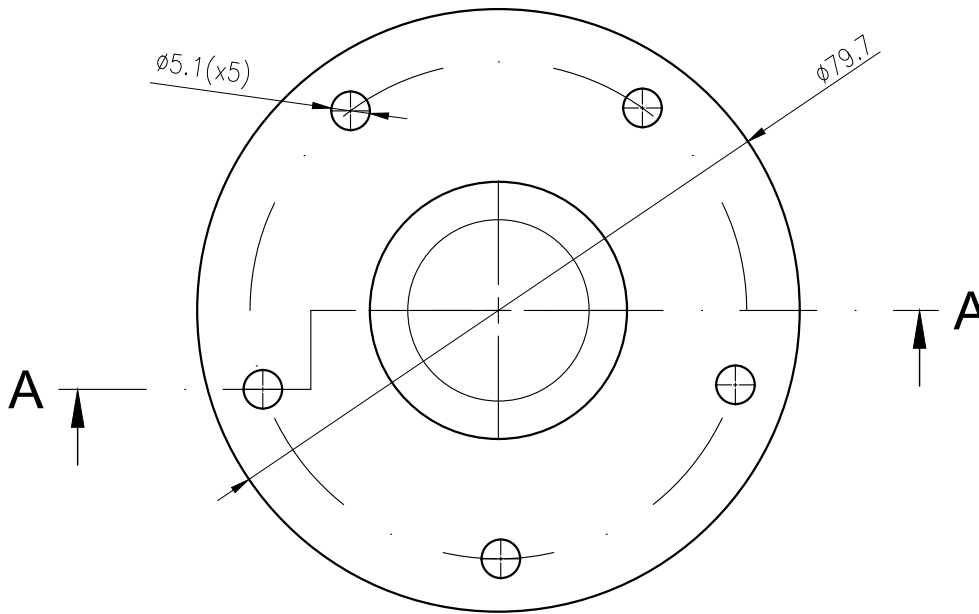
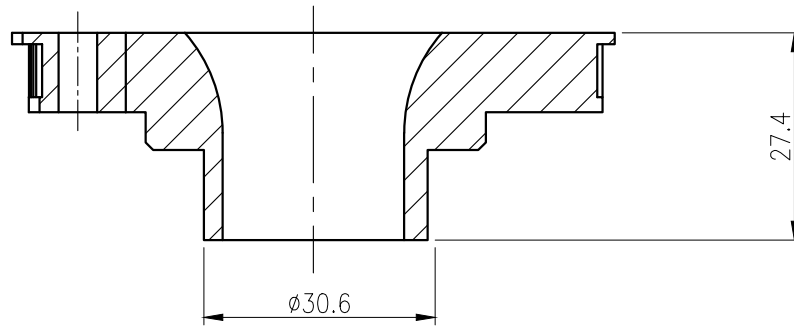

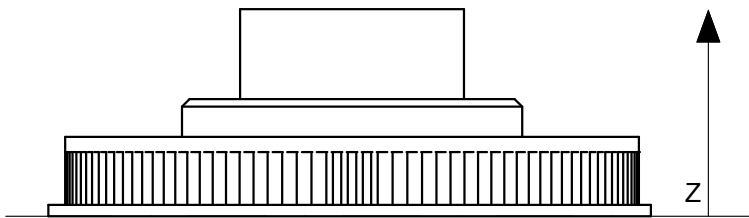

PRINT ORIENTATION



Printing Parameters

Material	80-20 PLA/CF
Extruder Diameter	0.4 mm
Layer Height	0.1 mm
Shell Thickness	1 mm
Infill	20%
Extruder Temperature	230 °C
Bed Temperature	70 °C
Supports	N

	Cognom, Nom	Data	ELISAVA Escola Superior de Disseny i Enginyeria de Barcelona GRAU EN ENGINYERIA EN DISSENY INDUSTRIAL
Autor	Latorre, Alex	05/05/2022	
Tutor	Chacón, Jonathan / Mestres, Francesc	05/05/2022	
 	Nom Projecte:	MOTUS	
Escala 1:1	Descripció:	J0_120T GT2 PULLEY	
Pes 20 g		Nº Plànol:	OSH.01_00.04_0
		Material:	80-20 PLA/CF
		Tractament / Acabat:	-

PRINT ORIENTATION

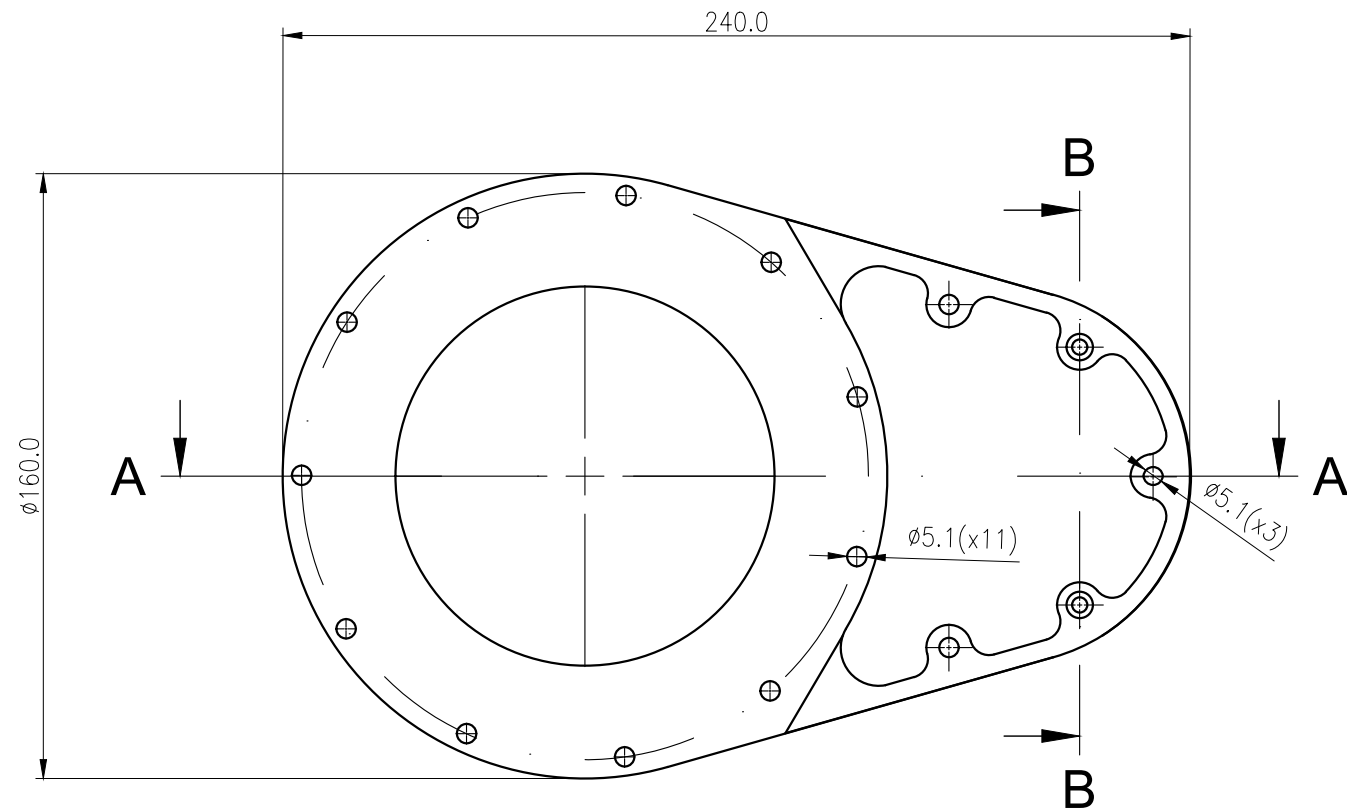

B-B (1:2)

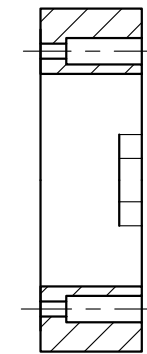

A-A (1:2)

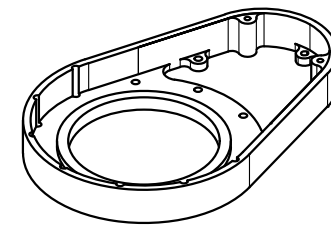
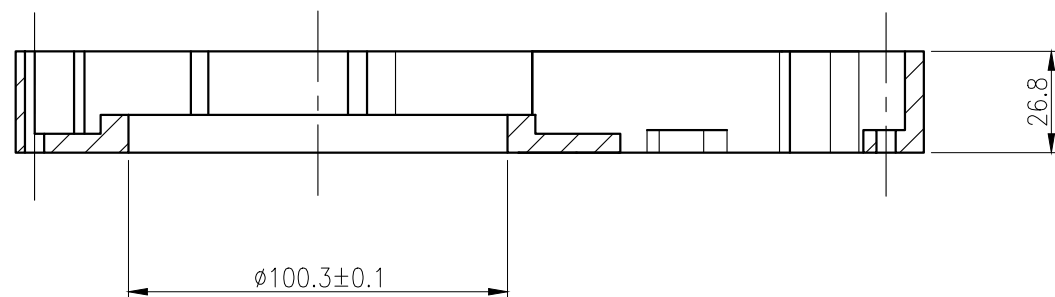

SCALE 1:5

Printing Parameters

Material	PLA
Extruder Diameter	0.4 mm
Layer Height	0.2 mm
Shell Thickness	1 mm
Infill	20%
Extruder Temperature	220 °C
Bed Temperature	60 °C
Supports	N

Cognom, Nom	Latorre, Alex		Data	05/05/2022
Autor	Chacón, Jonathan / Mestres, Francesc		Data	05/05/2022
Tutor	Nom Projecte:		MOTUS	Nº Plànol:
	Descripció:		J0_BASE	OSH.01_00.05_0
Material:	PLA			
Tractament / Acabat:	-			
Escala	1:2			
Pes	81 g			

ELISAVA Escola Superior de Disseny i Enginyeria de Barcelona

GRAU EN ENGINYERIA EN DISSENY INDUSTRIAL

A-A (1:1)

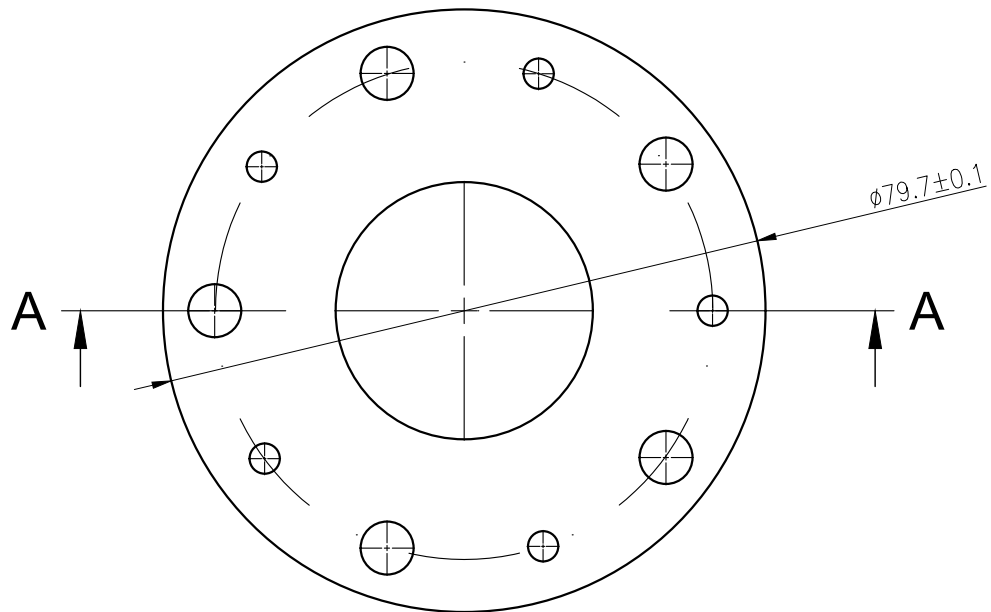
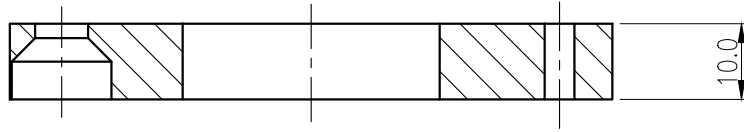

PRINT ORIENTATION



Printing Parameters

Material	PLA
Extruder Diameter	0.4 mm
Layer Height	0.2 mm
Shell Thickness	1 mm
Infill	20%
Extruder Temperature	220 °C
Bed Temperature	60 °C
Supports	N

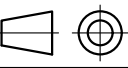
	Cognom, Nom	Data	ELISAVA Escola Superior de Disseny i Enginyeria de Barcelona GRAU EN ENGINYERIA EN DISSENY INDUSTRIAL
Autor	Latorre, Alex	05/05/2022	
Tutor	Chacón, Jonathan / Mestres, Francesc	05/05/2022	
	Nom Projecte:	MOTUS	Nº Plànol: OSH.01_00.06_0
Escala 1:1	Descripció:	J0_PULLEYTOP	Material: PLA
Pes 12 g			Tractament / Acabat: -

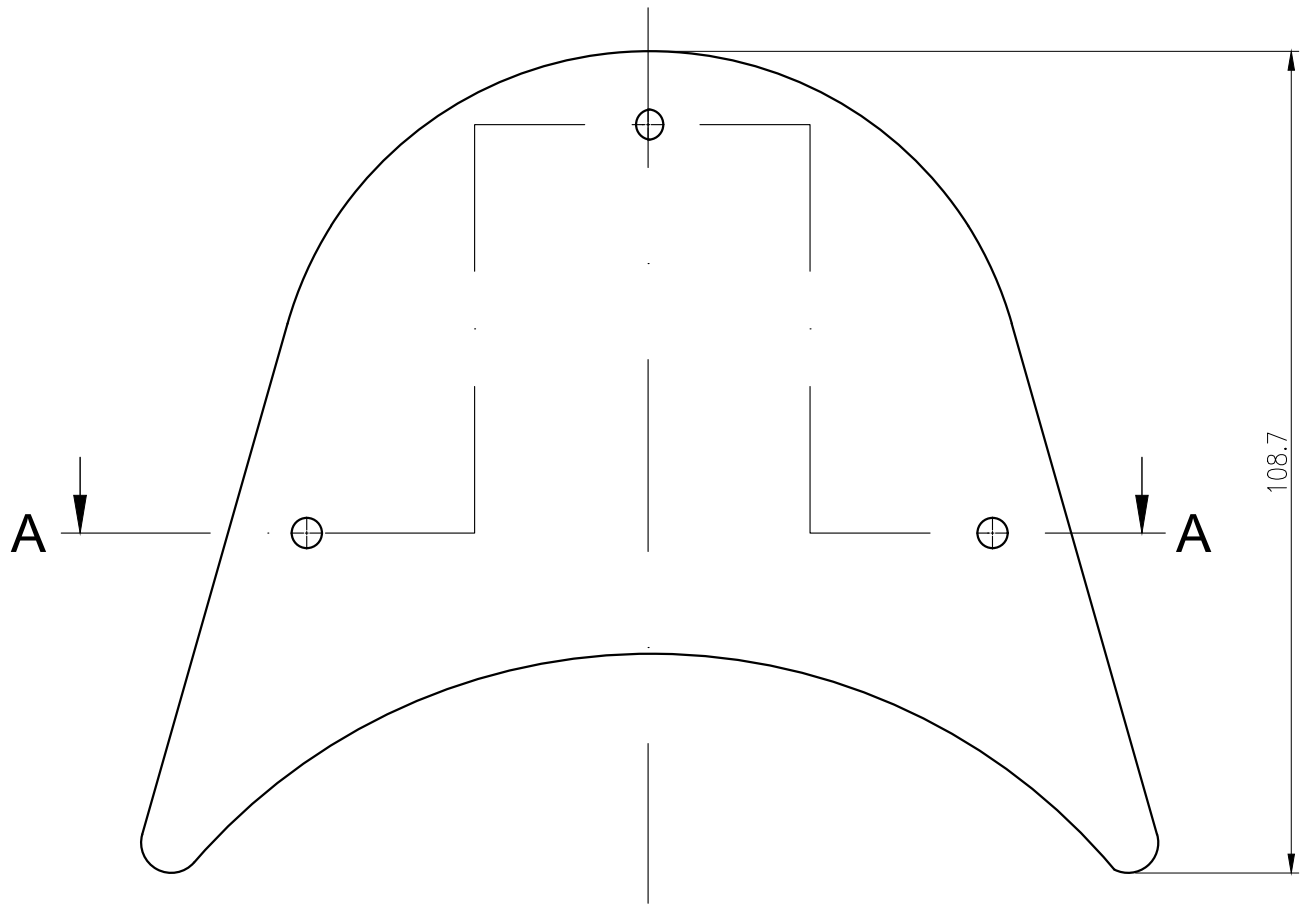

A-A (1:1)

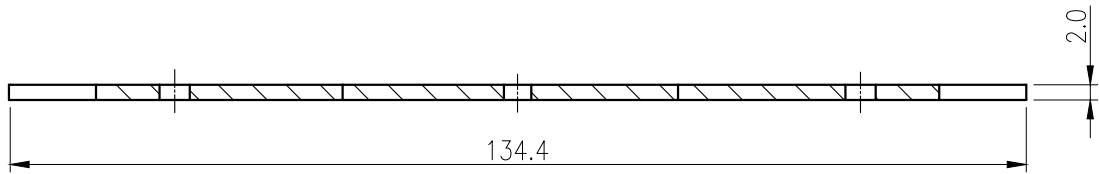

PRINT ORIENTATION

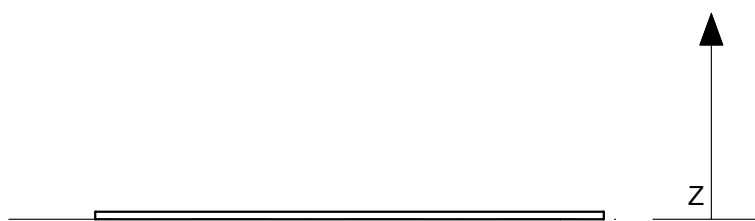

Printing Parameters

Material	PLA
Extruder Diameter	0.4 mm
Layer Height	0.2 mm
Shell Thickness	1 mm
Infill	20%
Extruder Temperature	220 °C
Bed Temperature	60 °C
Supports	N

	Cognom, Nom	Data
Autor	Latorre, Alex	05/05/2022
Tutor	Chacón, Jonathan / Mestres, Francesc	05/05/2022
	Nom Projecte:	MOTUS
Escala 1:1	Descripció:	J0_MOTORLID
Pes 19 g		

ELISAVA Escola Superior de Disseny i Enginyeria de Barcelona	
GRAU EN ENGINYERIA EN DISSENY INDUSTRIAL	
Nº Plànol:	OSH.01_00.07_0
Material:	PLA
Tractament / Acabat:	-

A-A (1:2)

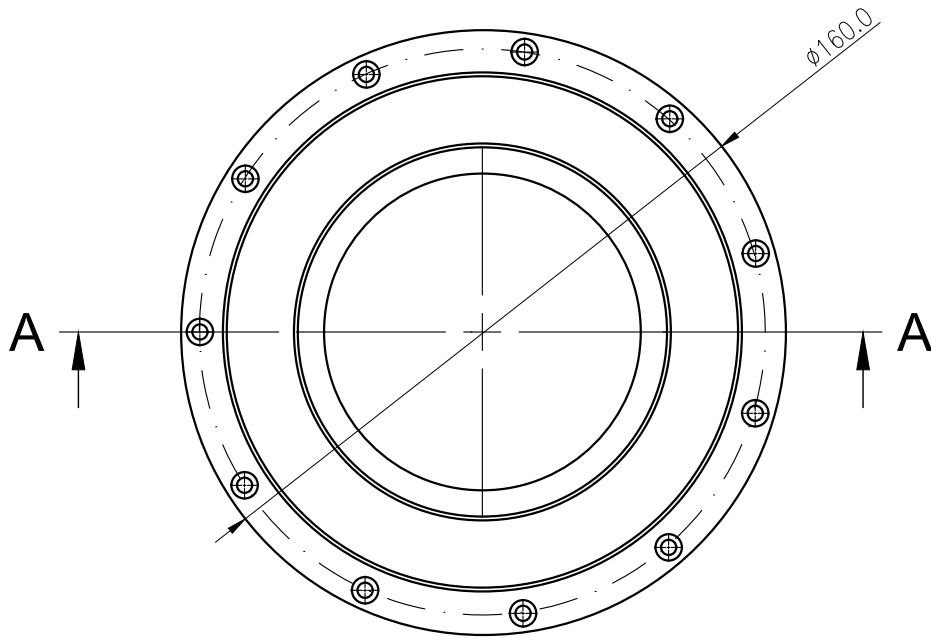
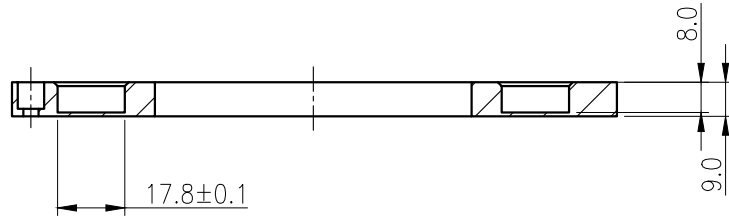

PRINT ORIENTATION

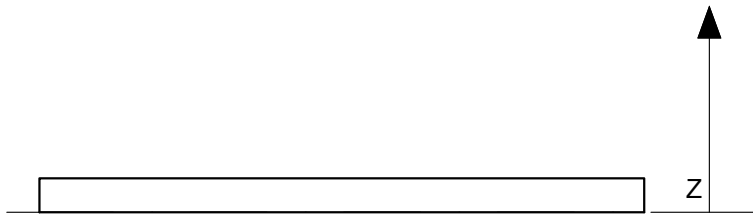

Printing Parameters

Material	PLA
Extruder Diameter	0.4 mm
Layer Height	0.2 mm
Shell Thickness	1 mm
Infill	20%
Extruder Temperature	220 °C
Bed Temperature	60 °C
Supports	N

	Cognom, Nom	Data	ELISAVA Escola Superior de Disseny i Enginyeria de Barcelona GRAU EN ENGINYERIA EN DISSENY INDUSTRIAL
Autor	Latorre, Alex	05/05/2022	
Tutor	Chacón, Jonathan / Mestres, Francesc	05/05/2022	
	Nom Projecte:	MOTUS	Nº Plànol: OSH.01_00.08_0
Escala 1:2	Descripció:	J0_TOP	Material: PLA
Pes 43 g			Tractament / Acabat: -

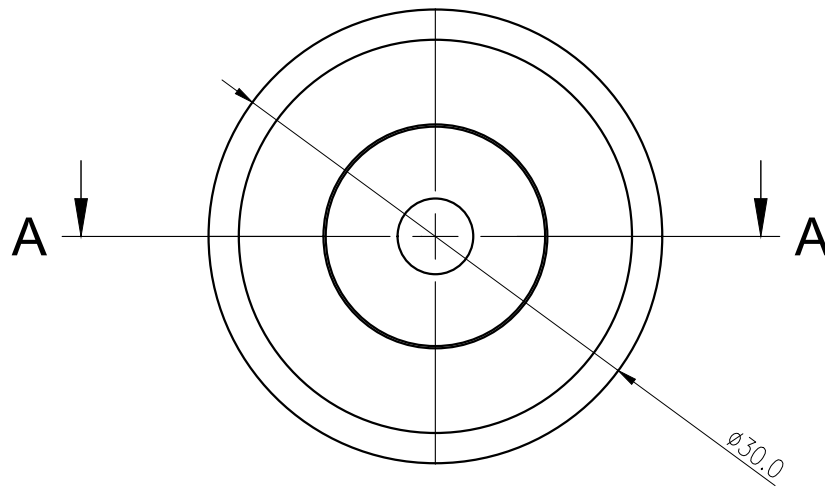

A-A (2:1)

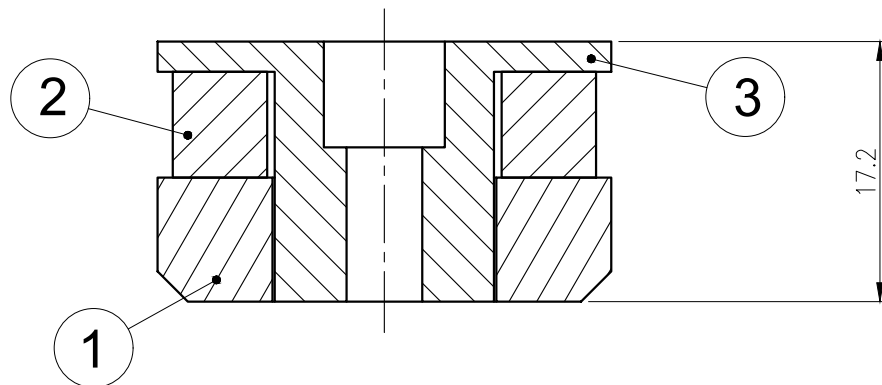

3	TENSOR_TOP	1	OSH.01_01.03_0		PLA	3 g
2	TENSOR_CENTER	1	OSH.01_01.02_0		PLA	2 g
1	TENSOR_BOTTOM	1	OSH.01_01.01_0		PLA	2 g
Marca	Descripció	Quant.	Nº Plànol / Codi	Norma / Referència	Material	Pes
	Cognom, Nom		Data	ELISAVA Escola Superior de Disseny i Enginyeria de Barcelona		
Autor				GRAU EN ENGINYERIA EN DISSENY INDUSTRIAL		
Tutor				Nº Plànol:	OSH.01_01.00_0	
	Nom Projecte:	MOTUS		Material:	PLA	
Escala 2:1	Descripció:	TENSOR_ASSEMBLY		Tractament / Acabat:	-	
Pes 7 g						

A-A (2:1)

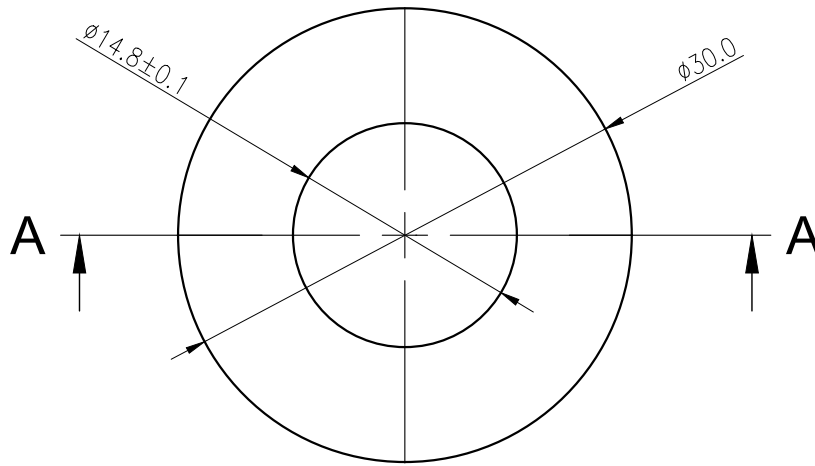
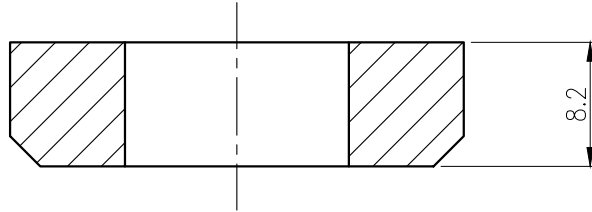

PRINT ORIENTATION

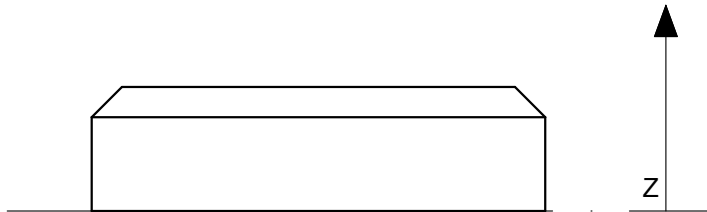

Printing Parameters	
Material	PLA
Extruder Diameter	0.4 mm
Layer Height	0.2 mm
Shell Thickness	1 mm
Infill	20%
Extruder Temperature	220 °C
Bed Temperature	60 °C
Supports	N

	Cognom, Nom	Data
Autor	Latorre, Alex	05/05/2022
Tutor	Chacón, Jonathan / Mestres, Francesc	05/05/2022
	Nom Projecte:	MOTUS
Escala 2:1	Descripció:	TENSOR_BOTTOM
Pes 2 g		

ELISAVA Escola Superior de Disseny i Enginyeria de Barcelona	
GRAU EN ENGINYERIA EN DISSENY INDUSTRIAL	
Nº Plànol:	OSH.01_01.01_0
Material:	PLA
Tractament / Acabat:	-

A-A (2:1)

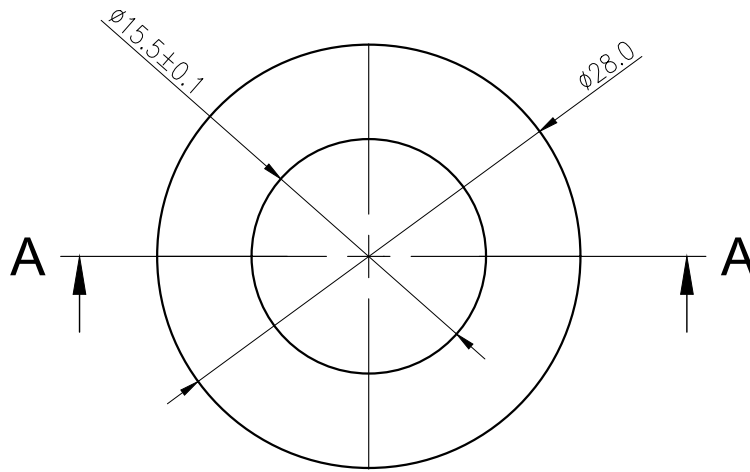
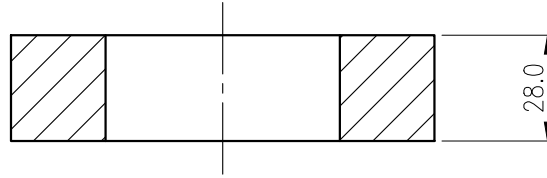

PRINT ORIENTATION



Printing Parameters

Material	PLA
Extruder Diameter	0.4 mm
Layer Height	0.2 mm
Shell Thickness	1 mm
Infill	20%
Extruder Temperature	220 °C
Bed Temperature	60 °C
Supports	N

	Cognom, Nom	Data	ELISAVA Escola Superior de Disseny i Enginyeria de Barcelona GRAU EN ENGINYERIA EN DISSENY INDUSTRIAL
Autor	Latorre, Alex	05/05/2022	
Tutor	Chacón, Jonathan / Mestres, Francesc	05/05/2022	
	Nom Projecte:	MOTUS	
Escala 2:1	Descripció:	SENSOR_CENTER	
Pes 2 g		Nº Plànol:	OSH.01_01.02_0
		Material:	PLA
		Tractament / Acabat:	-

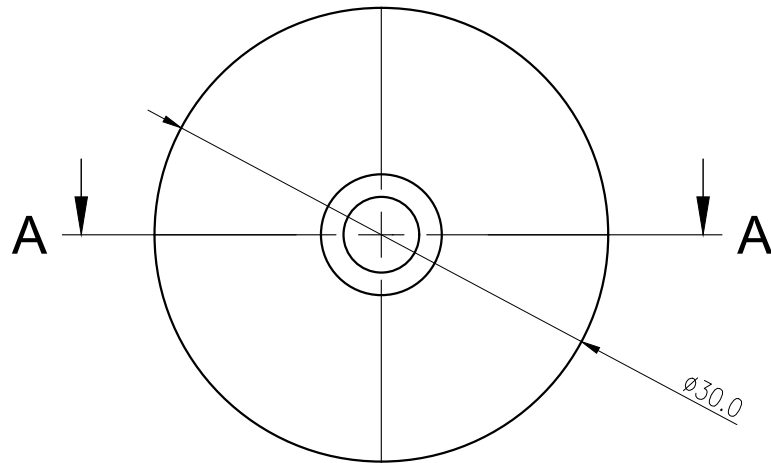

A-A (2:1)

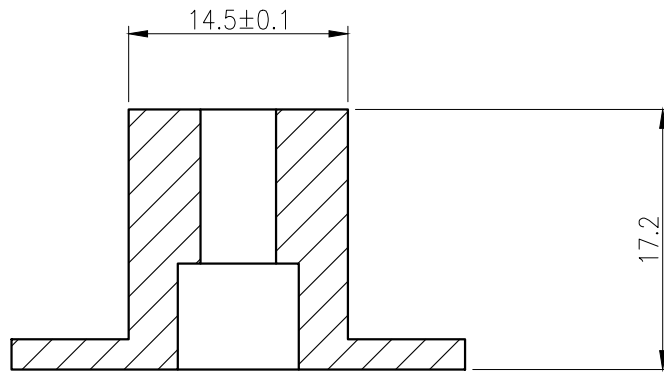

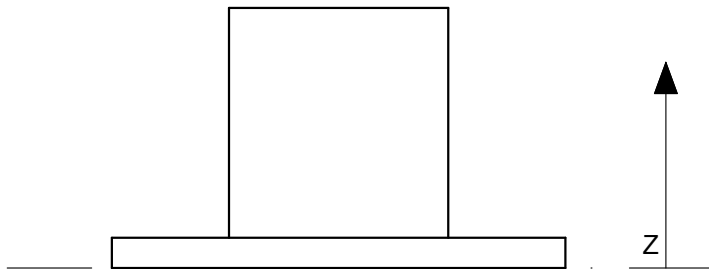

PRINT ORIENTATION



Printing Parameters

Material	PLA
Extruder Diameter	0.4 mm
Layer Height	0.2 mm
Shell Thickness	1 mm
Infill	20%
Extruder Temperature	220 °C
Bed Temperature	60 °C
Supports	Y

	Cognom, Nom	Data	ELISAVA Escola Superior de Disseny i Enginyeria de Barcelona GRAU EN ENGINYERIA EN DISSENY INDUSTRIAL
Autor	Latorre, Alex	05/05/2022	
Tutor	Chacón, Jonathan / Mestres, Francesc	05/05/2022	
 	Nom Projecte:	MOTUS	
Escala 2:1	Descripció:	SENSOR_TOP	
Pes 3 g		Nº Plànol:	OSH.01_01.03_0
		Material:	PLA
		Tractament / Acabat:	-

A-A (1:2)

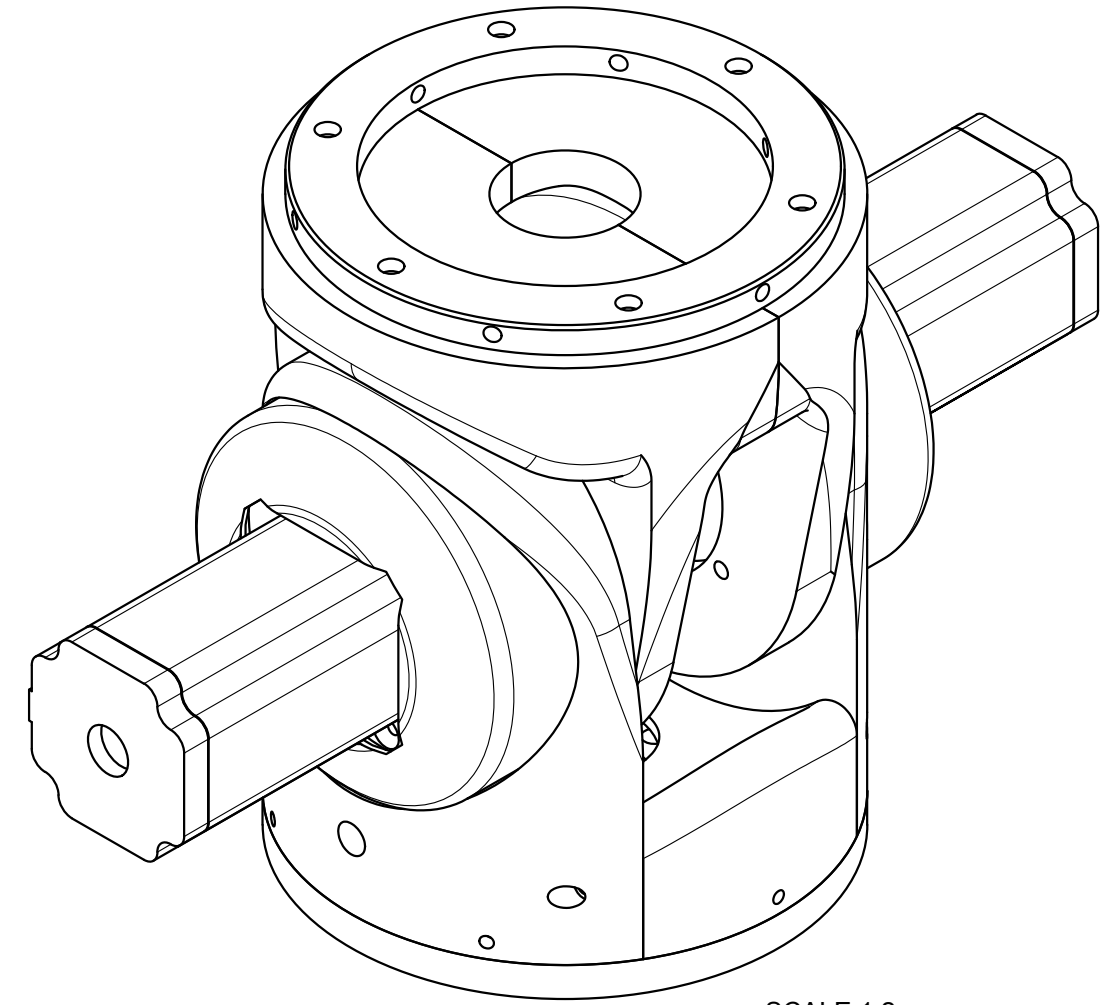
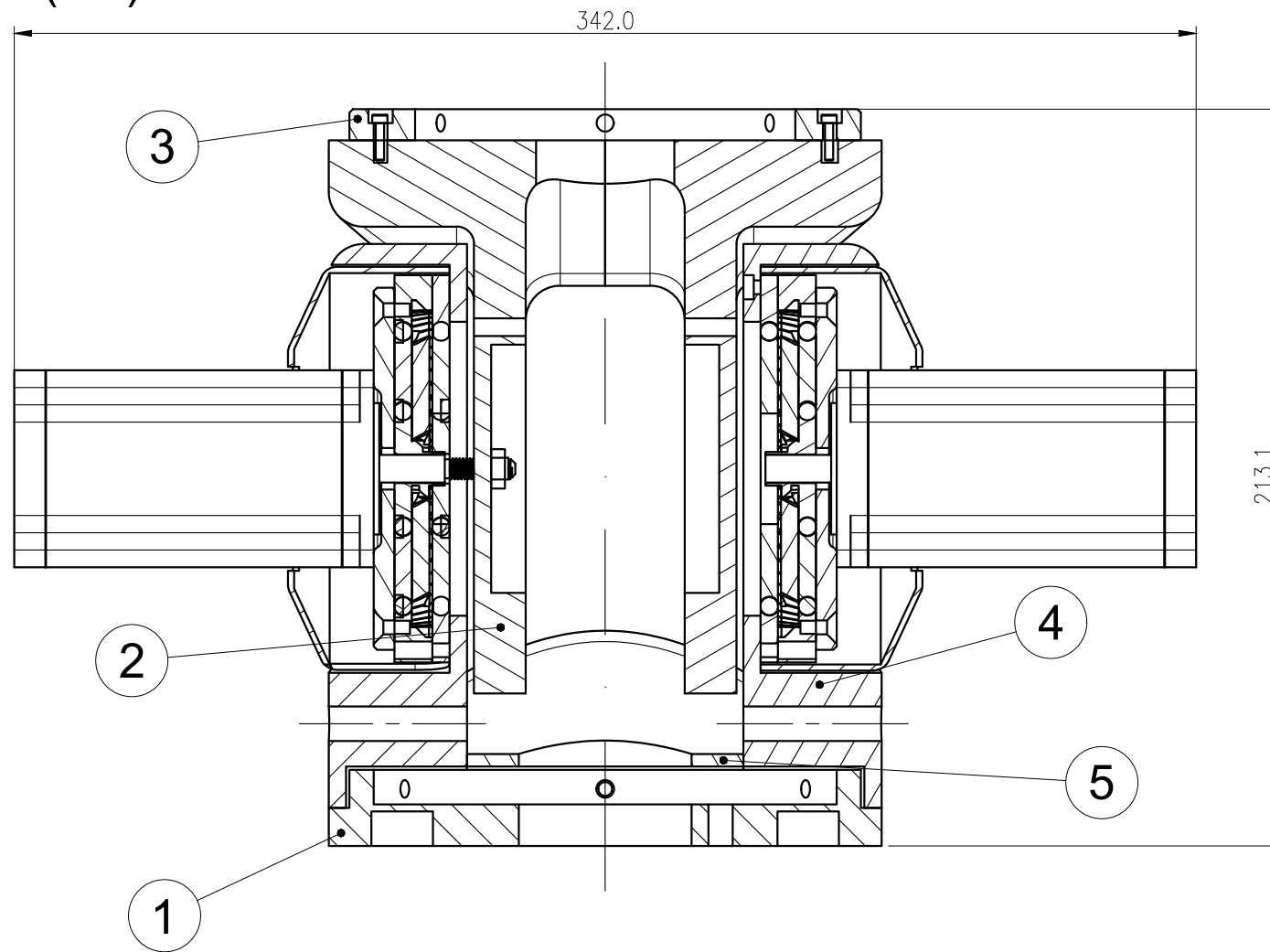

SCALE 1:2

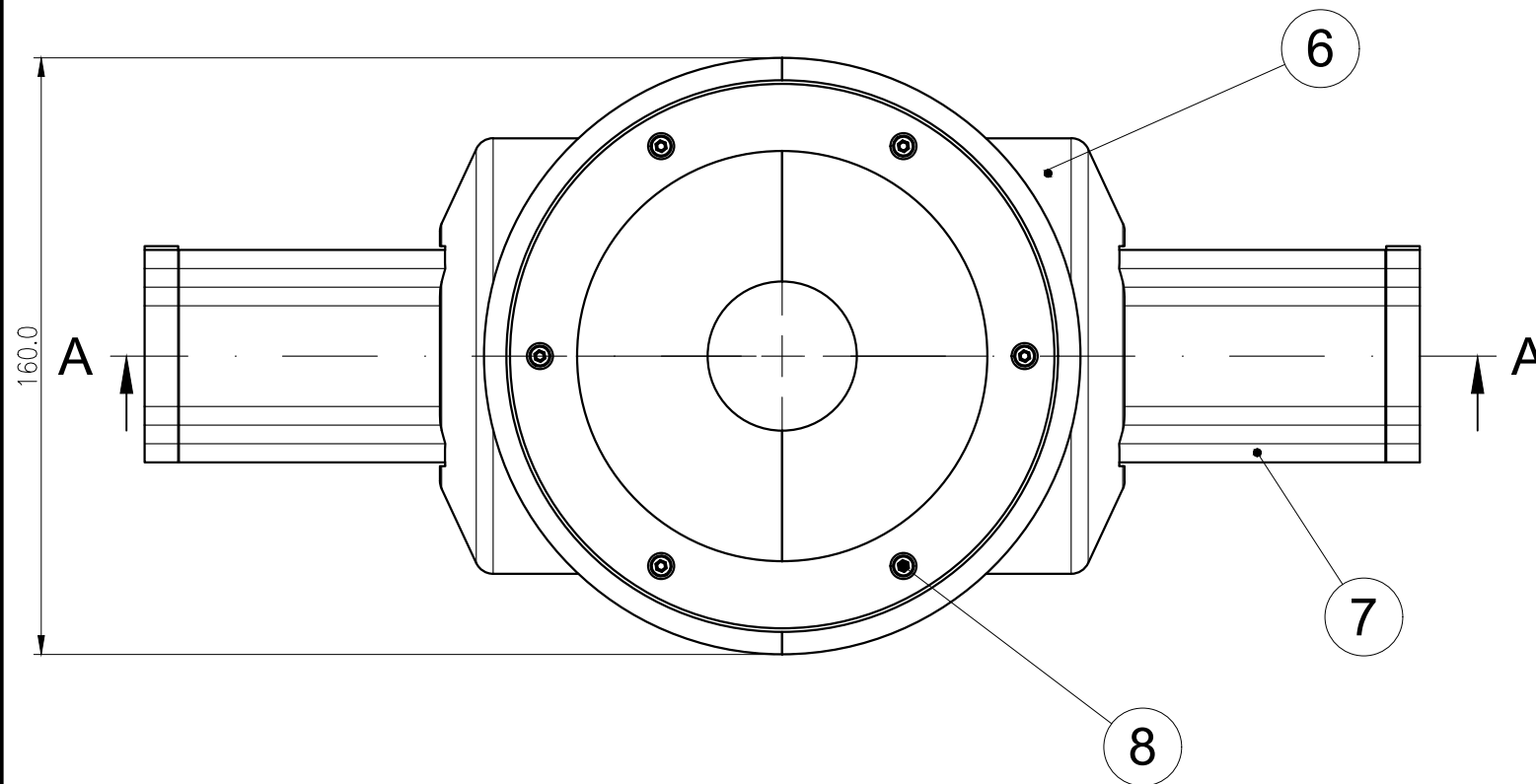

Quant.	Nº Plànol / Codi	Norma / Referència	Material	Pes		
8	M3x10 BOLT	DIN912	- g	-		
7	PLANETARY_GEARBOX	OSH.02_01.00_0	-	620 g		
6	J1_MOTORCOVER	OSH.02_00.06_0	PLA	44 g		
5	J1_BASEMIDDLE	OSH.02_00.02_0	PLA	59 g		
4	J1_BASESIDE	OSH.02_00.03_0	PLA	37 g		
3	J1_J2CONNECTOR	OSH.02_00.05_0	PLA	30 g		
2	J1_CONNECTOR	OSH.02_00.04_0	PLA	124 g		
1	J1_BASE	OSH.02_00.01_0	PLA	77 g		
Marca	Descripció	Quant.	Nº Plànol / Codi	Norma / Referència	Material	Pes

Cognom, Nom		Data		ELISAVA Escola Superior de Disseny i Enginyeria de Barcelona GRAU EN ENGINYERIA EN DISSENY INDUSTRIAL	
Autor	Latorre, Alex	05/05/2022			
Tutor	Chacón, Jonathan / Mestres, Francesc	05/05/2022		Nº Plànol: OSH.02_00.00_0	
Nom Projecte:		MOTUS		Material: -	
Descripció:		J1		Tractament / Acabat: -	
Escala 1:2					
Pes 1785 g					

A-A

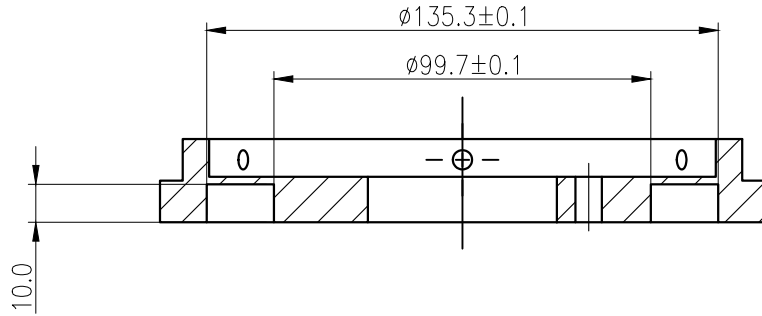

B-B

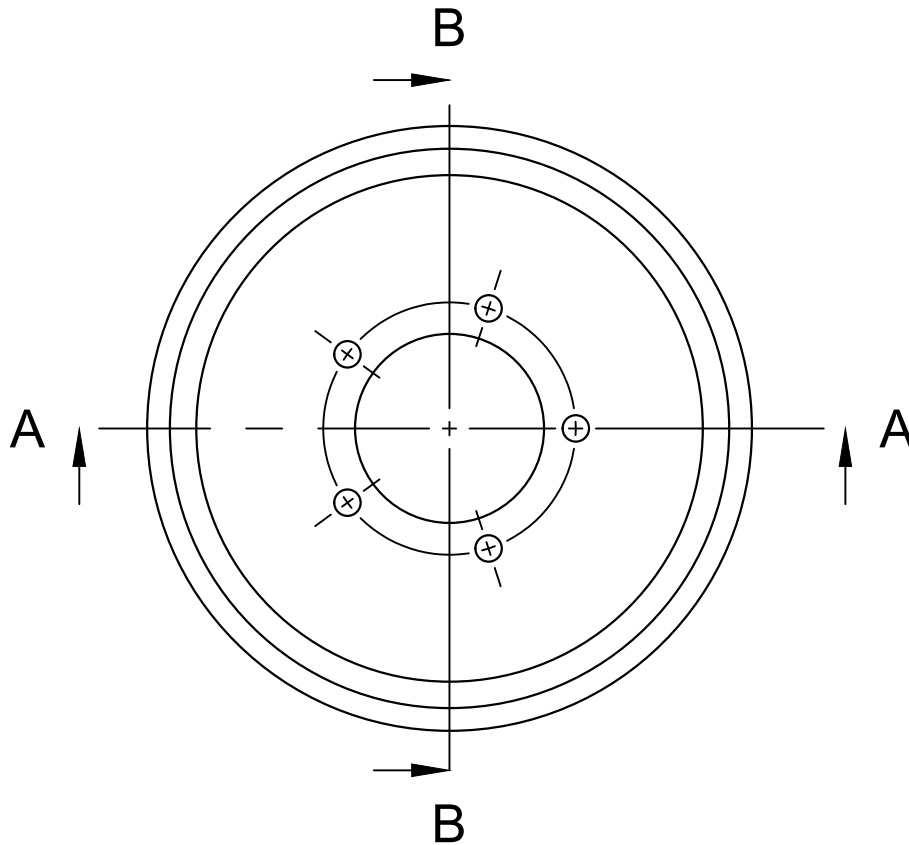
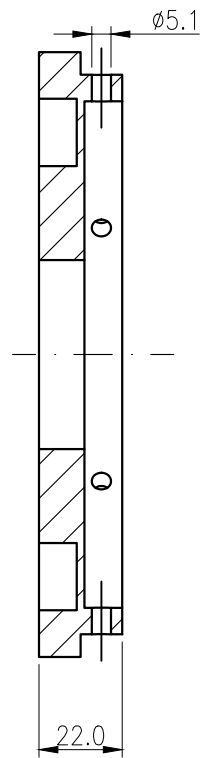

PRINT ORIENTATION

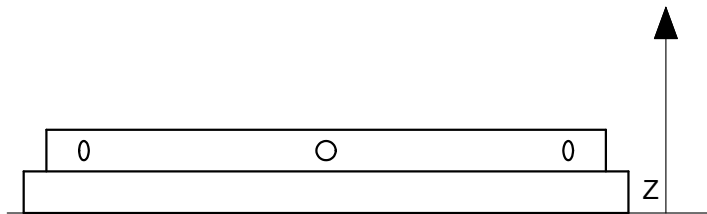

Printing Parameters

Material	PLA
Extruder Diameter	0.4 mm
Layer Height	0.2 mm
Shell Thickness	1 mm
Infill	20%
Extruder Temperature	220 °C
Bed Temperature	60 °C
Supports	Y

	Cognom, Nom	Data	ELISAVA Escola Superior de Disseny i Enginyeria de Barcelona
Autor	Latorre, Alex	05/05/2022	
Tutor	Chacón, Jonathan / Mestres, Francesc	05/05/2022	GRAU EN ENGINYERIA EN DISSENY INDUSTRIAL
	Nom Projecte:	MOTUS	Nº Plànol: OSH.02_00.01_0
Escala 1:2	Descripció:	J1_BASE	Material: PLA
Pes 77 g			Tractament / Acabat: -

A-A

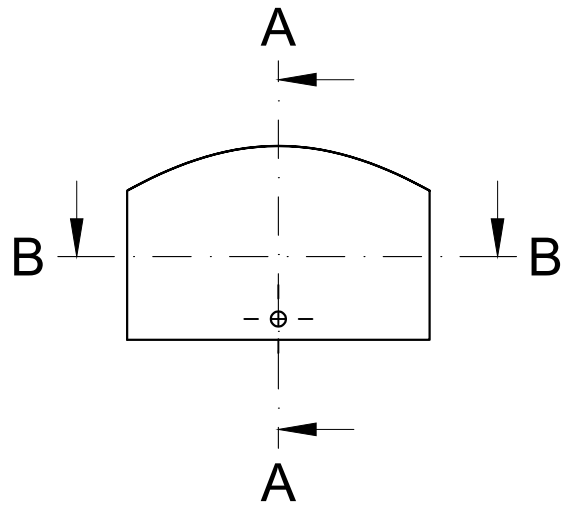
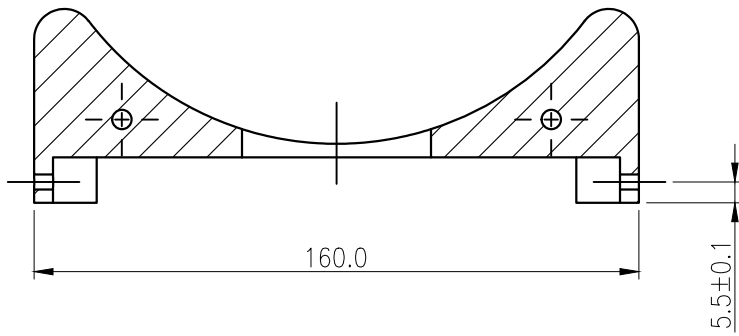

B-B

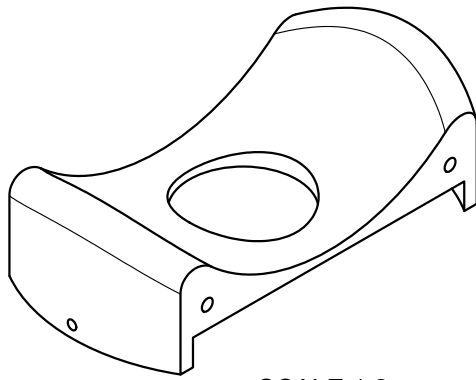

SCALE 1:2

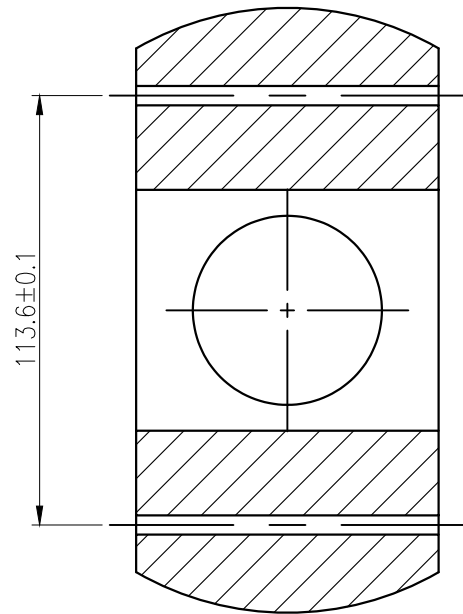

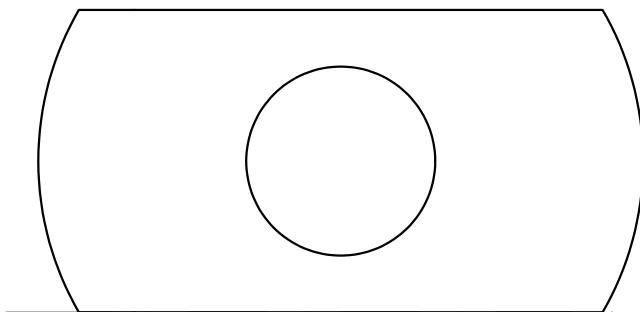

PRINT ORIENTATION



Printing Parameters

Material	PLA
Extruder Diameter	0.4 mm
Layer Height	0.2 mm
Shell Thickness	1 mm
Infill	20%
Extruder Temperature	220 °C
Bed Temperature	60 °C
Supports	N

	Cognom, Nom	Data	ELISAVA Escola Superior de Disseny i Enginyeria de Barcelona GRAU EN ENGINYERIA EN DISSENY INDUSTRIAL
Autor	Latorre, Alex	05/05/2022	
Tutor	Chacón, Jonathan / Mestres, Francesc	05/05/2022	
 	Nom Projecte:	MOTUS	
Escala 1:2	Descripció:	J1_BASEMIDDLE	
Pes 59 g		Nº Plànol:	OSH.02_00.02_0
		Material:	PLA
		Tractament / Acabat:	-

A-A

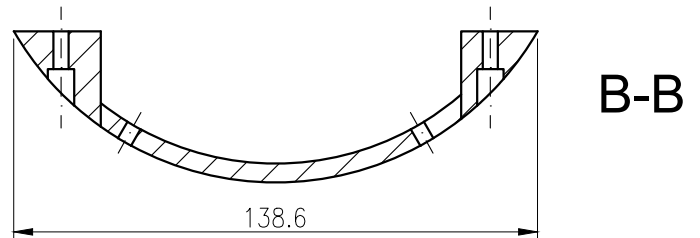
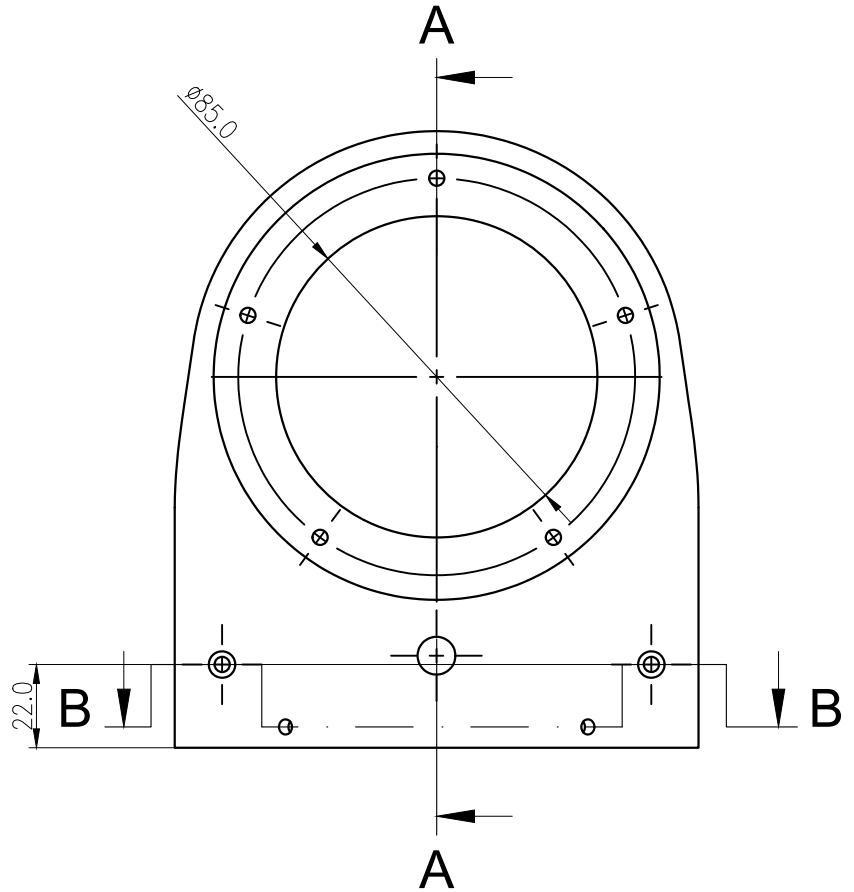
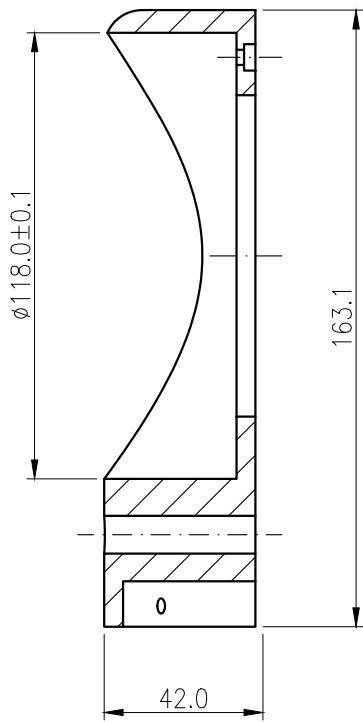

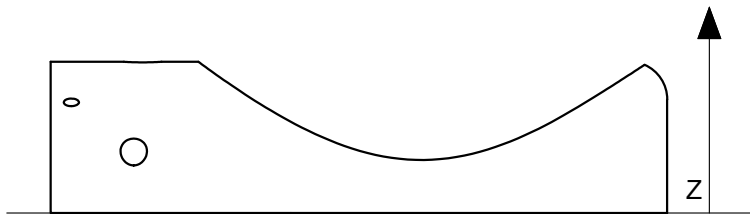

PRINT ORIENTATION



Printing Parameters

Material	PLA
Extruder Diameter	0.4 mm
Layer Height	0.2 mm
Shell Thickness	1 mm
Infill	20%
Extruder Temperature	220 °C
Bed Temperature	60 °C
Supports	N

	Cognom, Nom	Data
Autor	Latorre, Alex	05/05/2022
Tutor	Chacón, Jonathan / Mestres, Francesc	05/05/2022
 	Nom Projecte:	MOTUS
Escala 1:2	Descripció:	J1_BASESIDE
Pes 37 g		

ELISAVA Escola Superior de Disseny i Enginyeria de Barcelona	
GRAU EN ENGINYERIA EN DISSENY INDUSTRIAL	
Nº Plànol:	OSH.02_00.03_0
Material:	PLA
Tractament / Acabat:	-

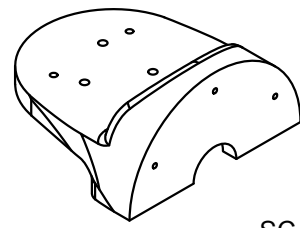

SCALE 1:5

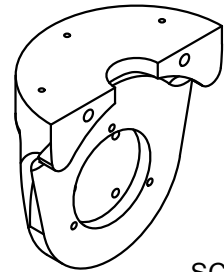

SCALE 1:5

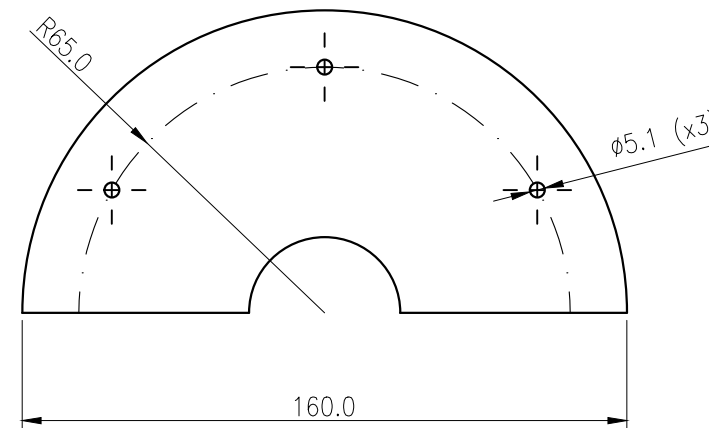
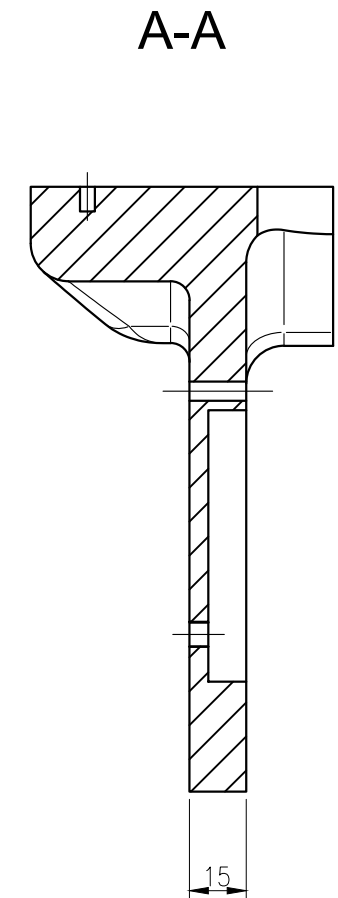
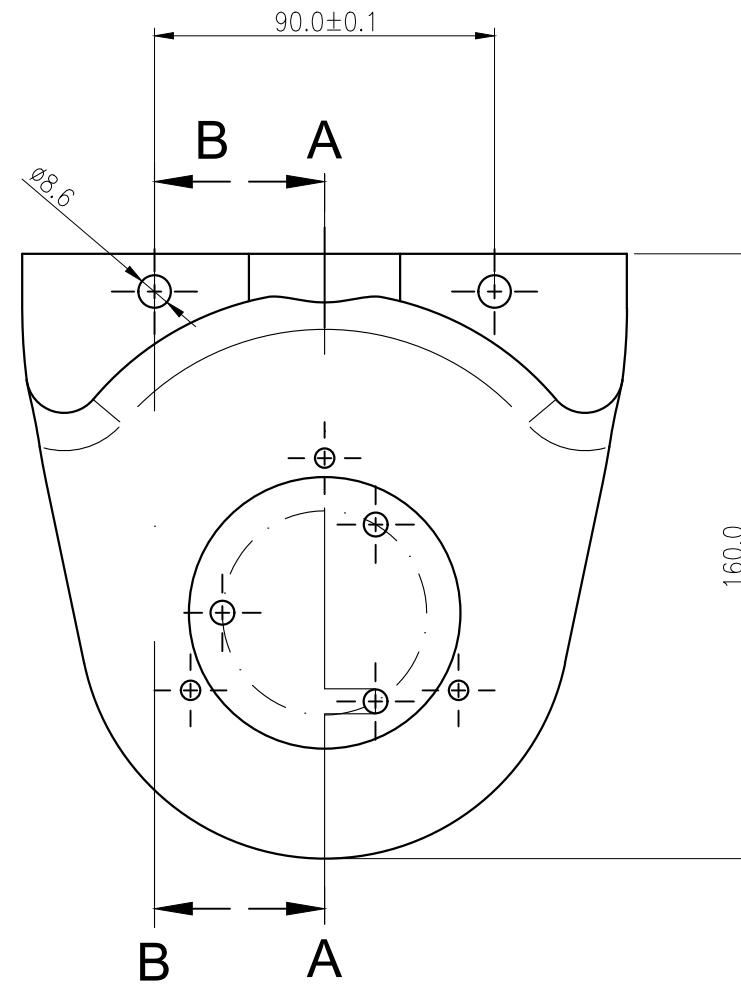
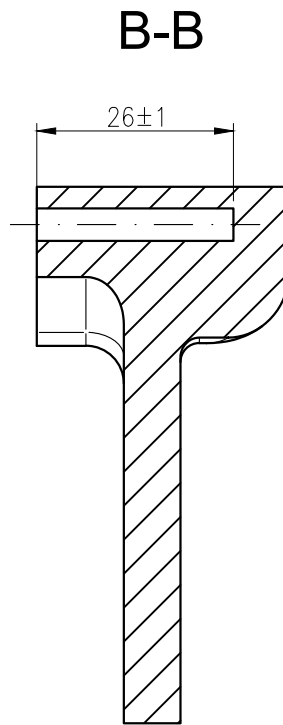

PRINT ORIENTATION

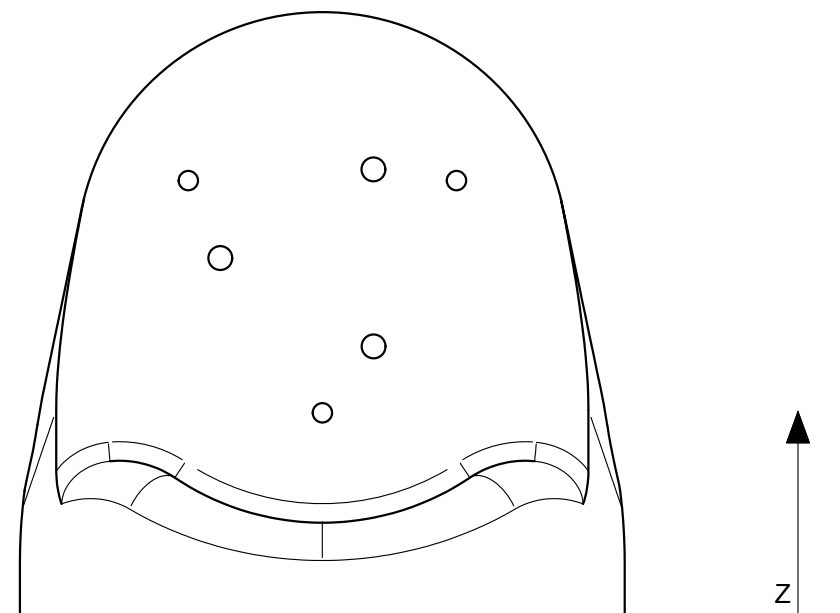

Printing Parameters	
Material	PLA
Extruder Diameter	0.4 mm
Layer Height	0.2 mm
Shell Thickness	1 mm
Infill	20%
Extruder Temperature	220 °C
Bed Temperature	60 °C
Supports	N

Cognom, Nom	Data	ELISAVA Escola Superior de Disseny i Enginyeria de Barcelona GRAU EN ENGINYERIA EN DISSENY INDUSTRIAL
Autor	05/05/2022	
Tutor	05/05/2022	
Nom Projecte:	MOTUS	Nº Plànol: OSH.02_00.04_0
Descripció:	J1_CONNECTOR	Material: PLA
Escala 1:2 Pes 124 g		Tractament / Acabat: -

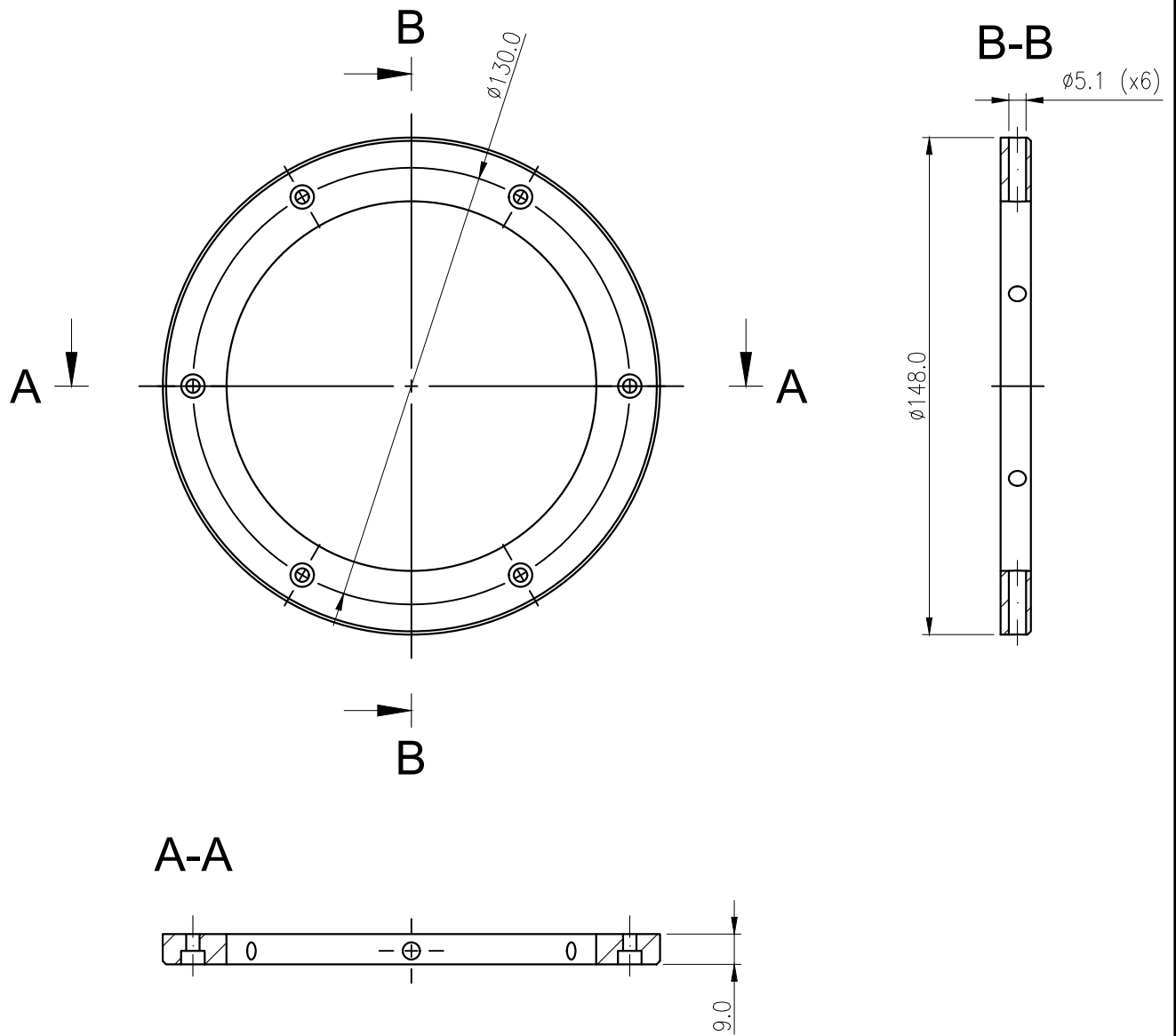

PRINT ORIENTATION

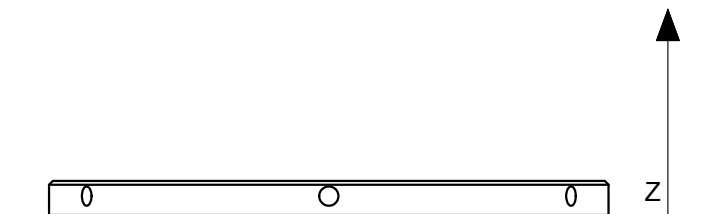

Printing Parameters

Material	PLA
Extruder Diameter	0.4 mm
Layer Height	0.2 mm
Shell Thickness	1 mm
Infill	20%
Extruder Temperature	220 °C
Bed Temperature	60 °C
Supports	N

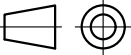
	Cognom, Nom	Data	ELISAVA Escola Superior de Disseny i Enginyeria de Barcelona GRAU EN ENGINYERIA EN DISSENY INDUSTRIAL
Autor	Latorre, Alex	05/05/2022	
Tutor	Chacón, Jonathan / Mestres, Francesc	05/05/2022	
	Nom Projecte:	MOTUS	Nº Plànol: OSH.02_00.05_0
Escala 1:2	Descripció:	J1_J2CONNECTOR	Material: PLA
Pes 30 g			Tractament / Acabat: -

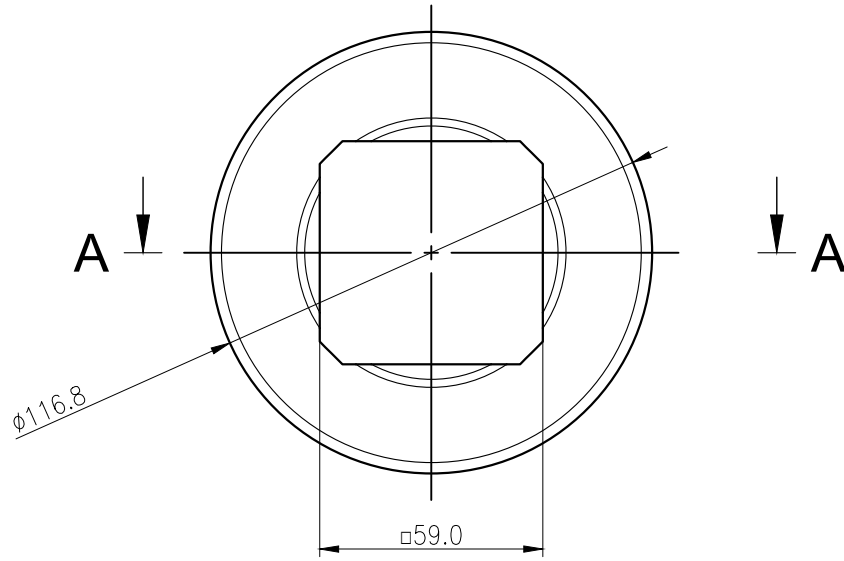

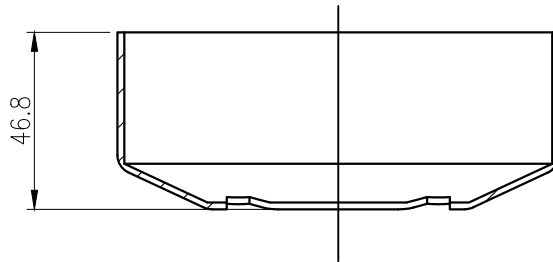

A-A (1:2)

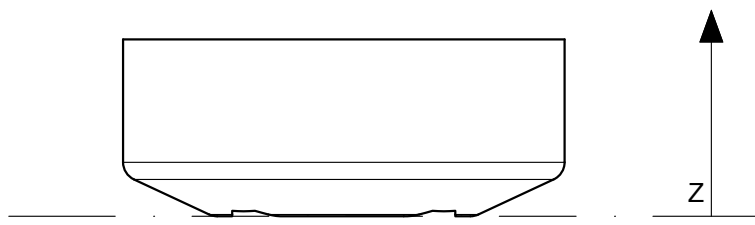

PRINT ORIENTATION



Printing Parameters	
Material	PLA
Extruder Diameter	0.4 mm
Layer Height	0.2 mm
Shell Thickness	1 mm
Infill	20%
Extruder Temperature	220 °C
Bed Temperature	60 °C
Supports	N

	Cognom, Nom	Data	ELISAVA Escola Superior de Disseny i Enginyeria de Barcelona GRAU EN ENGINYERIA EN DISSENY INDUSTRIAL
Autor	Latorre, Alex	05/05/2022	
Tutor	Chacón, Jonathan / Mestres, Francesc	05/05/2022	
 	Nom Projecte:	MOTUS	
Escala 1:2	Descripció:	J1_MOTORCOVER	
Pes 44 g		Nº Plànol:	OSH.02_00.06_0
		Material:	PLA
		Tractament / Acabat:	-

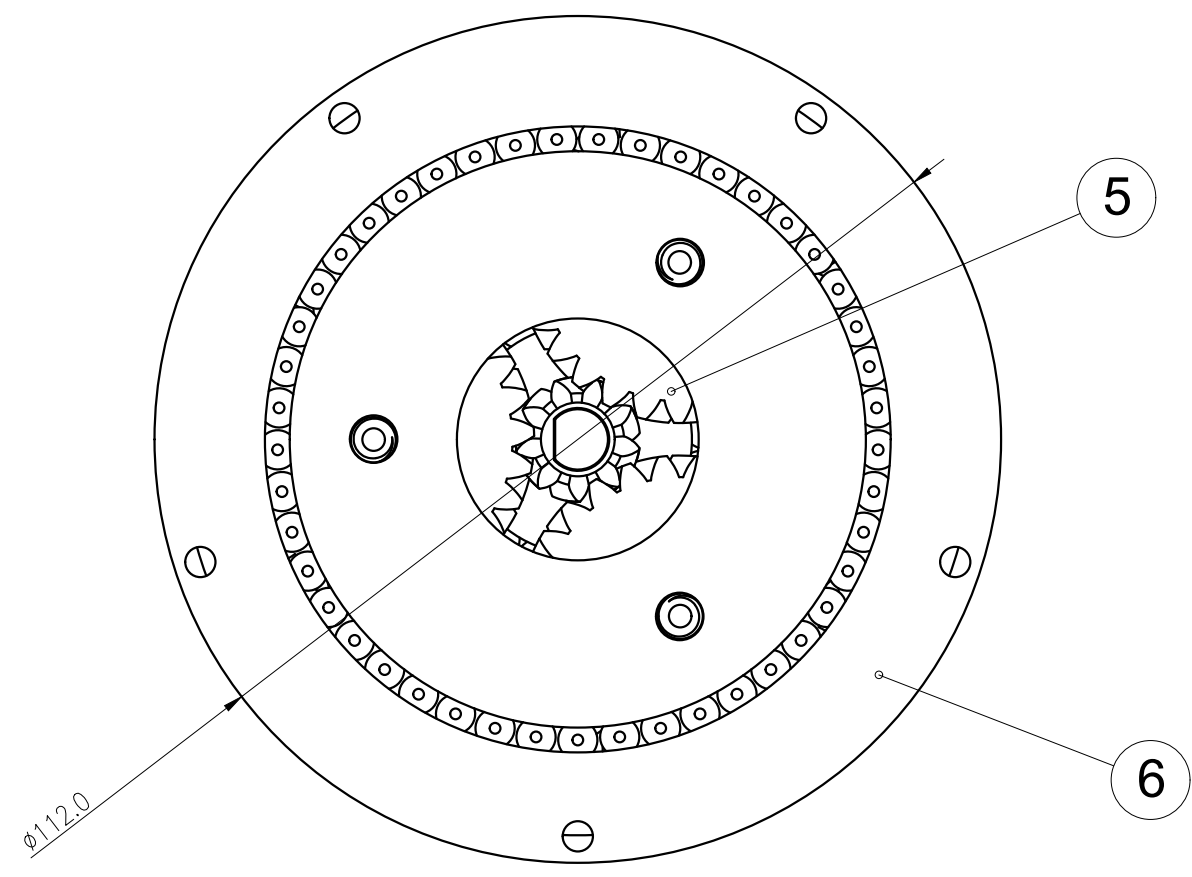
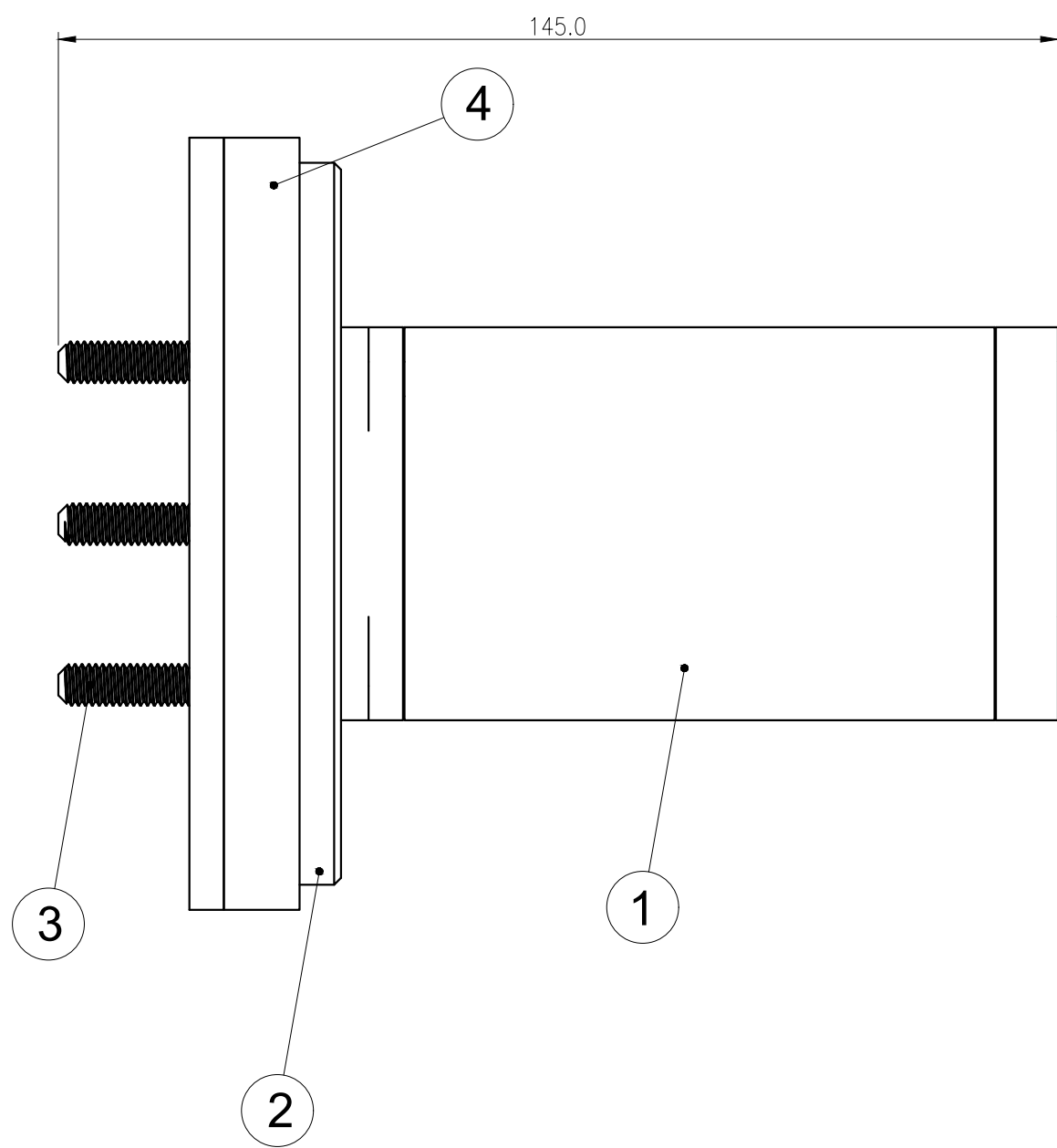

6	PLANETARY_LID	01	OSH.02_01.04_0		80-20 PLA/CF	26 g
5	PLANETARY_PLANET	03	OSH.02_01.03_0		80-20 PLA/CF	9 g
4	PLANETARY_SUN	01	OSH.02_01.02_0		80-20 PLA/CF	36 g
3	DIN7991 M6X35	03		DIN7991		- g
2	PLANETARY_BOTTOM	01	OSH.02_01.01_0		PLA	24 g
1	STEPPER MOTOR 23HS41-1804S	01		23HS41-1804S		420 g
Marca	Descripció	Quant.	Nº Plànol / Codi	Norma / Referència	Material	Pes
	Cognom, Nom		Data	ELISAVA Escola Superior de Disseny i Enginyeria de Barcelona GRAU EN ENGINYERIA EN DISSENY INDUSTRIAL		
Autor	Latorre, Alex		05/05/2022			
Tutor	Chacón, Jonathan / Mestres, Francesc		05/05/2022			
	Nom Projecte:	MOTUS		Nº Plànol:	OSH.02_01.00_A	
Escaleta	Descripció:	PLANETARY_GEARBOX		Material:	-	
1:1				Tractament / Acabat:	-	
Pes						
620 g						

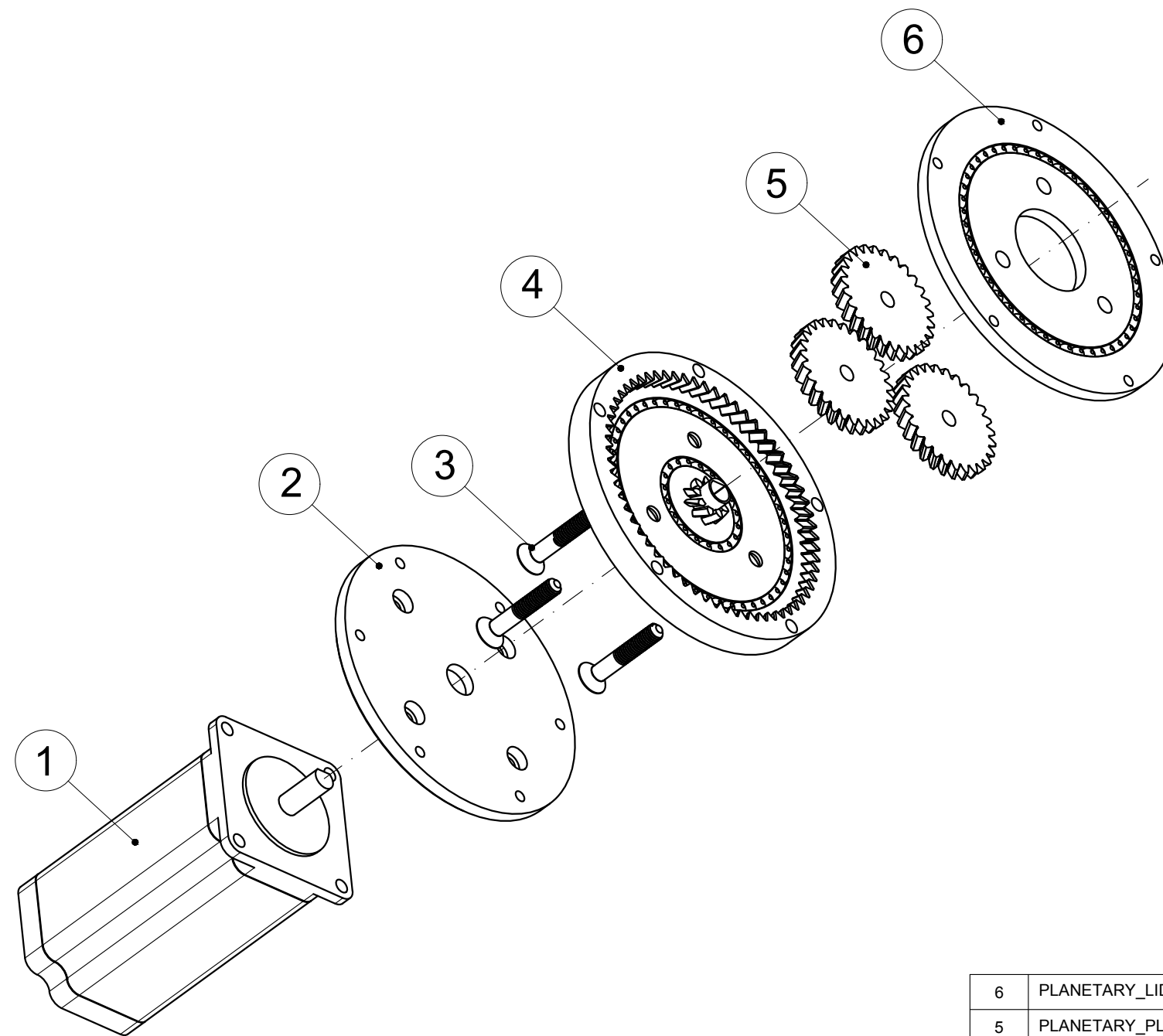

6	PLANETARY_LID	01	OSH.02_01.04_0		80-20 PLA/CF	26 g
5	PLANETARY_PLANET	03	OSH.02_01.03_0		80-20 PLA/CF	9 g
4	PLANETARY_SUN	01	OSH.02_01.02_0		80-20 PLA/CF	36 g
3	DIN7991 M6X35	03		DIN7991		- g
2	PLANETARY_BOTTOM	01	OSH.02_01.01_0		PLA	24 g
1	STEPPER MOTOR 23HS41-1804S	01		23HS41-1804S		420 g
Marca	Descripció	Quant.	Nº Plànol / Codi	Norma / Referència	Material	Pes
	Cognom, Nom		Data	ELISAVA Escola Superior de Disseny i Enginyeria de Barcelona GRAU EN ENGINYERIA EN DISSENY INDUSTRIAL		
Autor	Latorre, Alex		05/05/2022			
Tutor	Chacón, Jonathan / Mestres, Francesc		05/05/2022			
	Nom Projecte:	MOTUS		Nº Plànol:	OSH.02_01.00_B	
Escala 1:2	Descripció:	PLANETARY_GEARBOX EXP.		Material:	-	
Pes 620 g				Tractament / Acabat:	-	

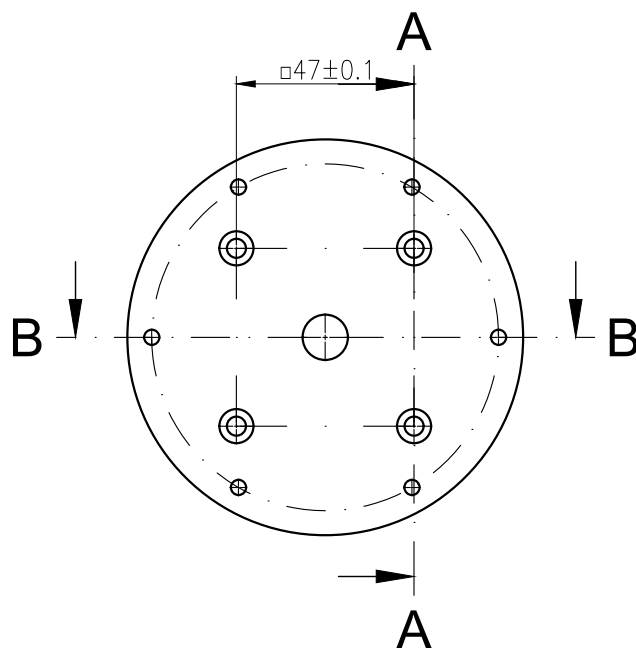

A-A (1:2)

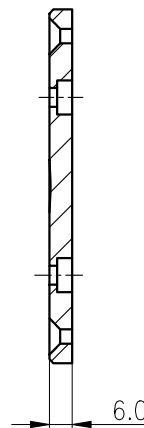

B-B (1:2)

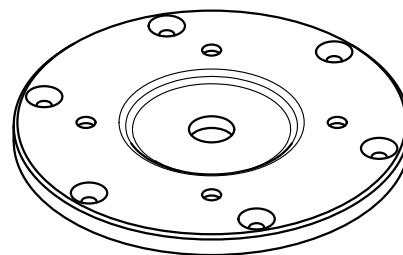
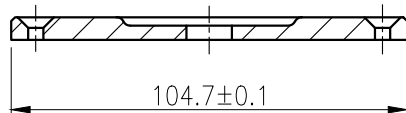

SCALE 1:2

PRINT ORIENTATION



Printing Parameters

Material	PLA
Extruder Diameter	0.4 mm
Layer Height	0.2 mm
Shell Thickness	1 mm
Infill	20%
Extruder Temperature	220 °C
Bed Temperature	60 °C
Supports	N

	Cognom, Nom	Data	ELISAVA Escola Superior de Disseny i Enginyeria de Barcelona
Autor	Latorre, Alex	05/05/2022	
Tutor	Chacón, Jonathan / Mestres, Francesc	05/05/2022	GRAU EN ENGINYERIA EN DISSENY INDUSTRIAL
	Nom Projecte:	MOTUS	Nº Plànol: OSH.02_01.01_0
Escala 1:2	Descripció:	PLANETARY_BOTTOM	Material: PLA
Pes 24 g			Tractament / Acabat: -

A-A (1:1)

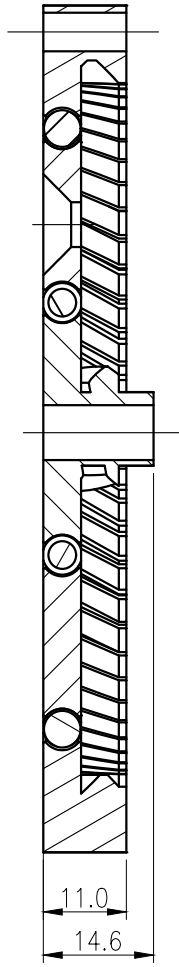
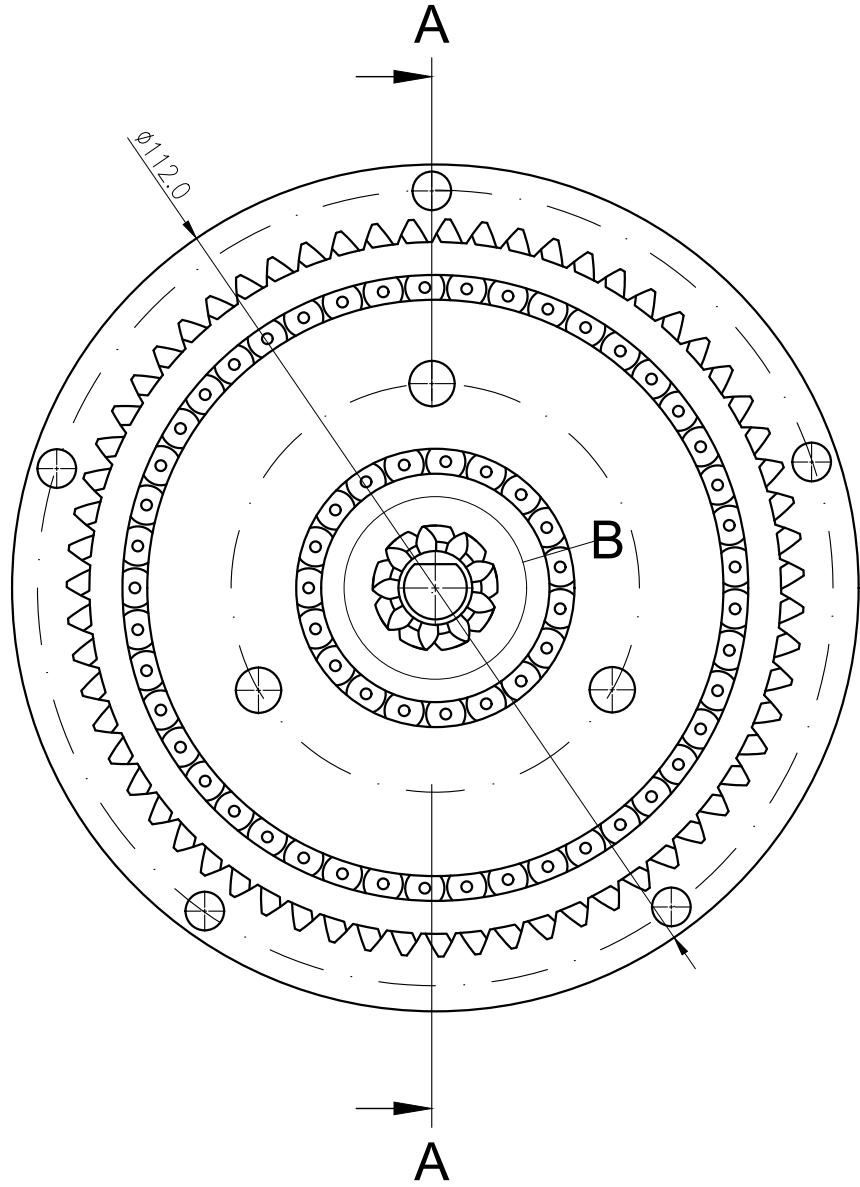

B (5:1)

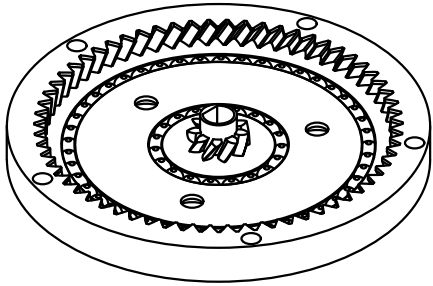
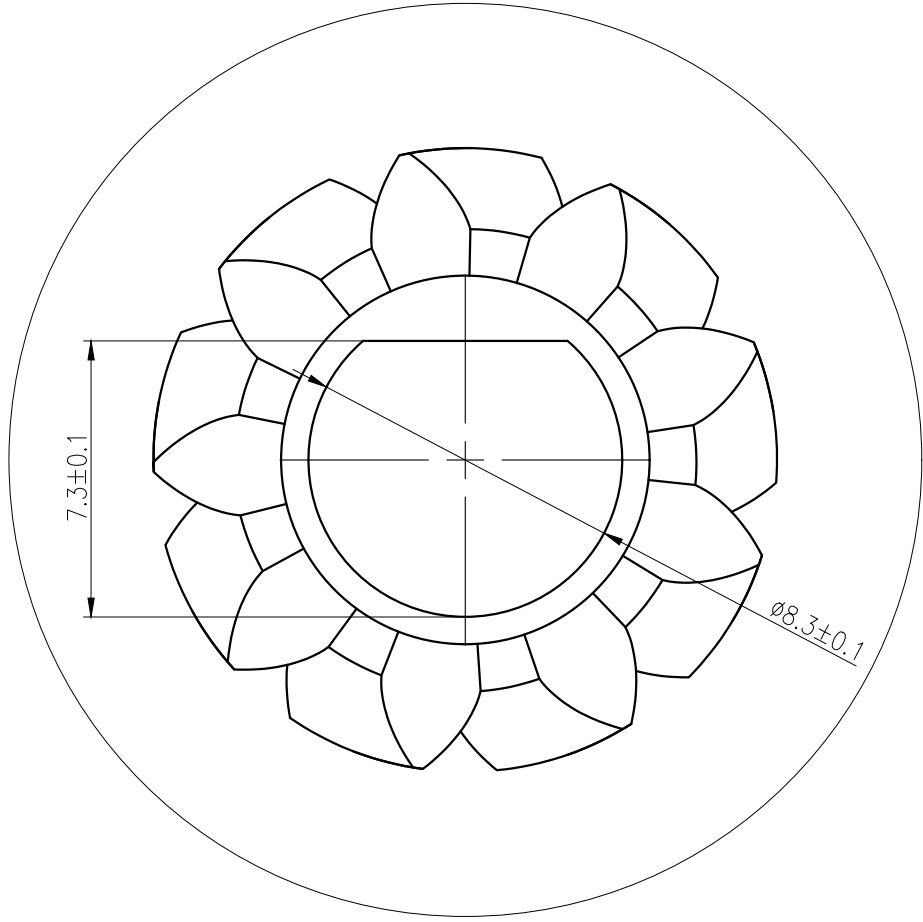

SCALE 1:2

Printing Parameters	
Material	80-20 PLA/CF
Extruder Diameter	0.4 mm
Layer Height	0.1 mm
Shell Thickness	1 mm
Infill	20%
Extruder Temperature	230 °C
Bed Temperature	70 °C
Supports	N

PRINT ORIENTATION

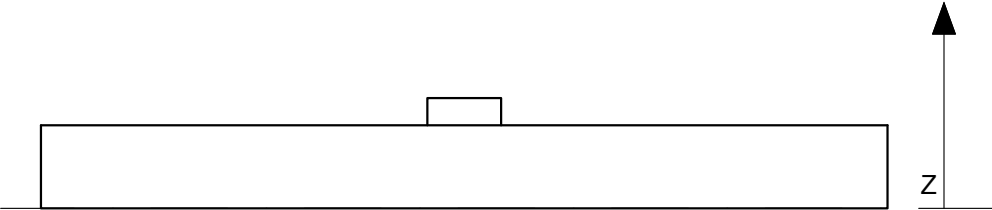

	Cognom, Nom	Data	ELISAVA Escola Superior de Disseny i Enginyeria de Barcelona
Autor	Latorre, Alex	05/05/2022	
Tutor	Chacón, Jonathan / Mestres, Francesc	05/05/2022	GRAU EN ENGINYERIA EN DISSENY INDUSTRIAL
	Nom Projecte:	Nº Plànol: OSH.02_01.02_0	
		MOTUS	
	Descripció:	Material: 80-20 PLA/CF	
		Tractament / Acabat: -	
	Escales		
	1:1		
	Pes		
	36 g		

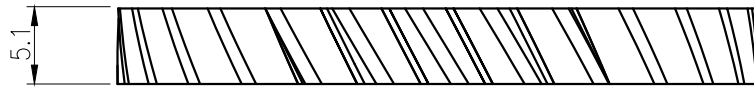
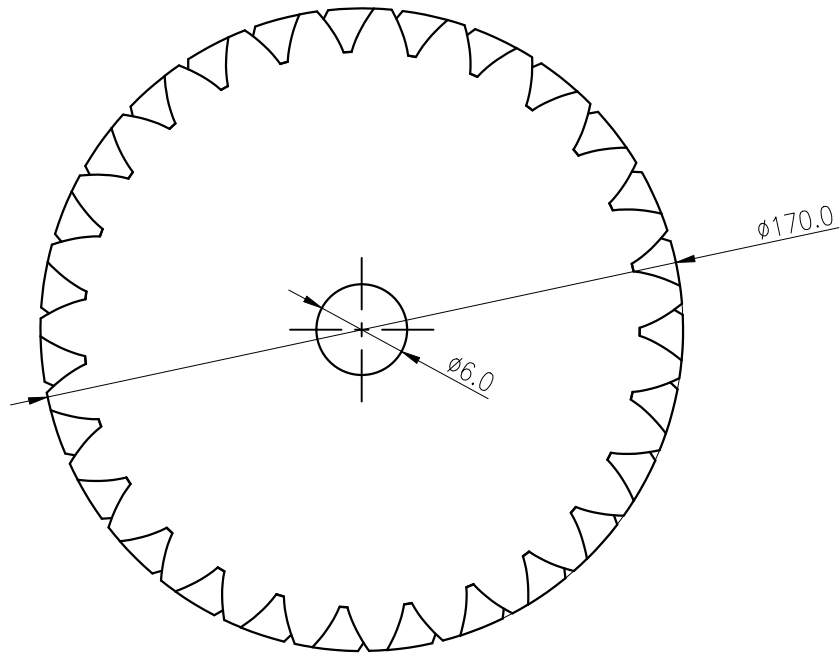

PRINT ORIENTATION



Z

Printing Parameters

Material	80-20 PLA/CF
Extruder Diameter	0.4 mm
Layer Height	0.1 mm
Shell Thickness	1 mm
Infill	20%
Extruder Temperature	230 °C
Bed Temperature	70 °C
Supports	N

	Cognom, Nom	Data	ELISAVA Escola Superior de Disseny i Enginyeria de Barcelona GRAU EN ENGINYERIA EN DISSENY INDUSTRIAL
Autor	Latorre, Alex	05/05/2022	
Tutor	Chacón, Jonathan / Mestres, Francesc	05/05/2022	
	Nom Projecte:	MOTUS	
Escala 2:1	Descripció:	PLANETARY_PLANET	
Pes 3 g		Nº Plànol:	OSH.02_01.03_0
		Material:	80-20 PLA/CF
		Tractament / Acabat:	-

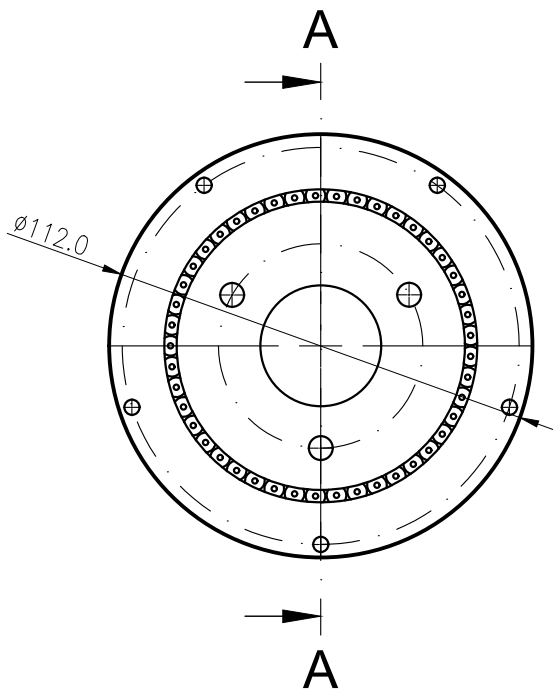

A-A (1:2)

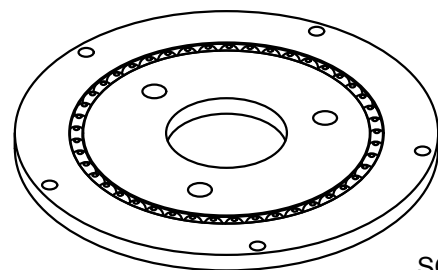
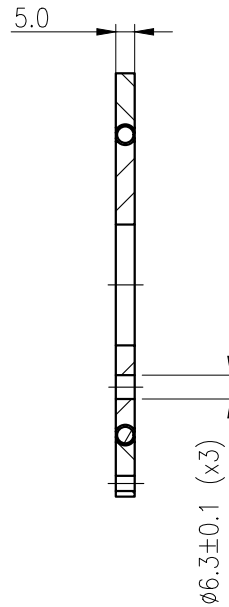

SCALE 1:2

PRINT ORIENTATION

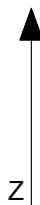
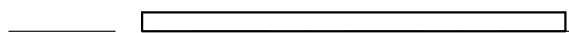

Printing Parameters

Material	80-20 PLA/CF
Extruder Diameter	0.4 mm
Layer Height	0.1 mm
Shell Thickness	1 mm
Infill	20%
Extruder Temperature	230 °C
Bed Temperature	70 °C
Supports	N

	Cognom, Nom	Data	ELISAVA Escola Superior de Disseny i Enginyeria de Barcelona GRAU EN ENGINYERIA EN DISSENY INDUSTRIAL
Autor	Latorre, Alex	05/05/2022	
Tutor	Chacón, Jonathan / Mestres, Francesc	05/05/2022	
	Nom Projecte:	MOTUS	Nº Plànol: OSH.02_01.04_0
Escala 1:2	Descripció:	PLANETARY_LID	Material: 80-20 PLA/CF
Pes 26 g			Tractament / Acabat: -

A-A (1:1)

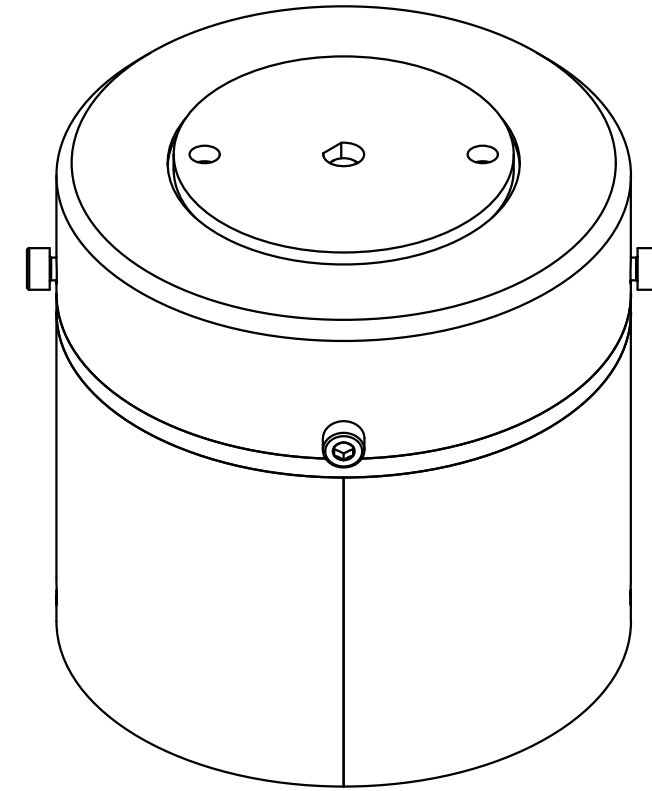
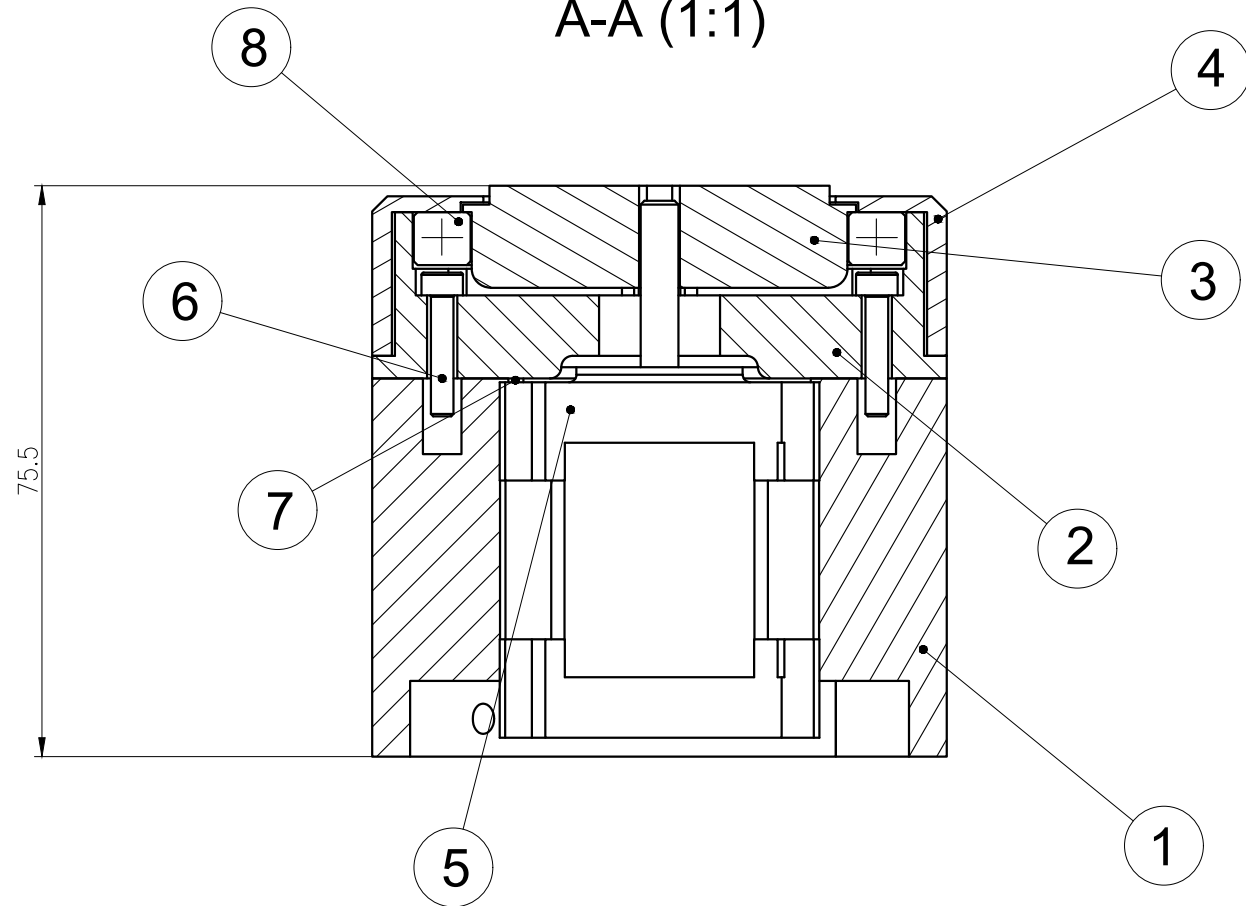

SCALE 1:1

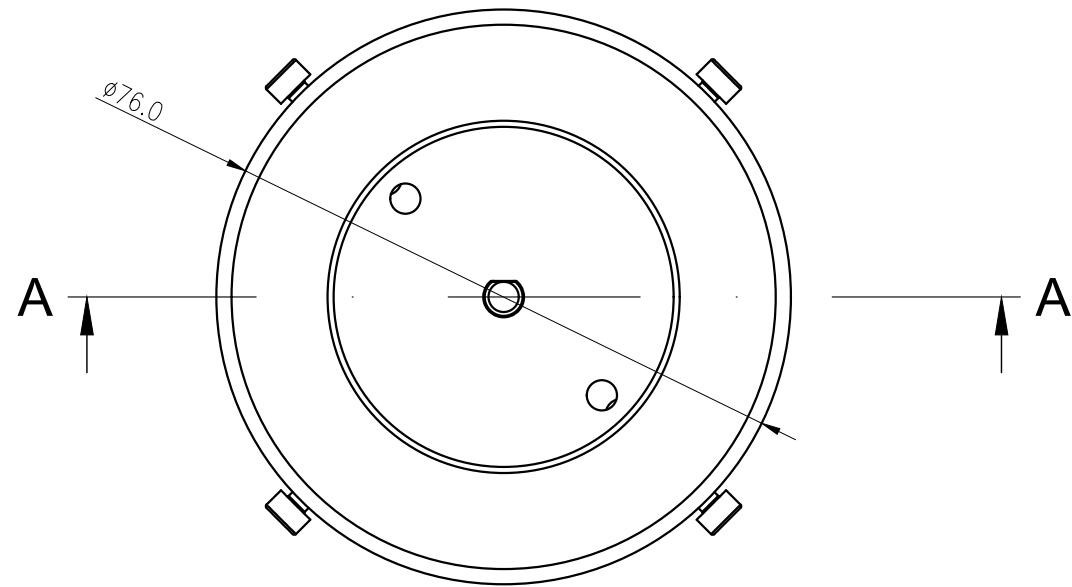

8	BEARING 6810ZZ	01		6810ZZ		- g
7	M3x10 BOLT	04		DIN912		- g
6	M3x16 BOLT	08		DIN912		- g
5	STEPPER MOTOR 35HT36-1004a	01		35HT36-1004a		420 g
4	J5_LID	01	OSH.06_00.04_0		PLA	42 g
3	J5_P01	01	OSH.06_00.03_0		PLA	12 g
2	J5_P02	01	OSH.06_00.02_0		PLA	23 g
1	J5_P03	02	OSH.06_00.01_0		PLA	15 g
Marca	Descripció	Quant.	Nº Plànol / Codi	Norma / Referència	Material	Pes
Cognom, Nom			Data		ELISAVA Escola Superior de Disseny i Enginyeria de Barcelona GRAU EN ENGINYERIA EN DISSENY INDUSTRIAL	
Autor	Latorre, Alex	05/05/2022				
Tutor	Chacón, Jonathan / Mestres, Francesc	05/05/2022				
Nom Projecte:			MOTUS		Nº Plànol: OSH.06_00.00_A	
Descripció:			J5		Material: -	
Escala 1:1					Tractament / Acabat: -	
Pes 512 g						

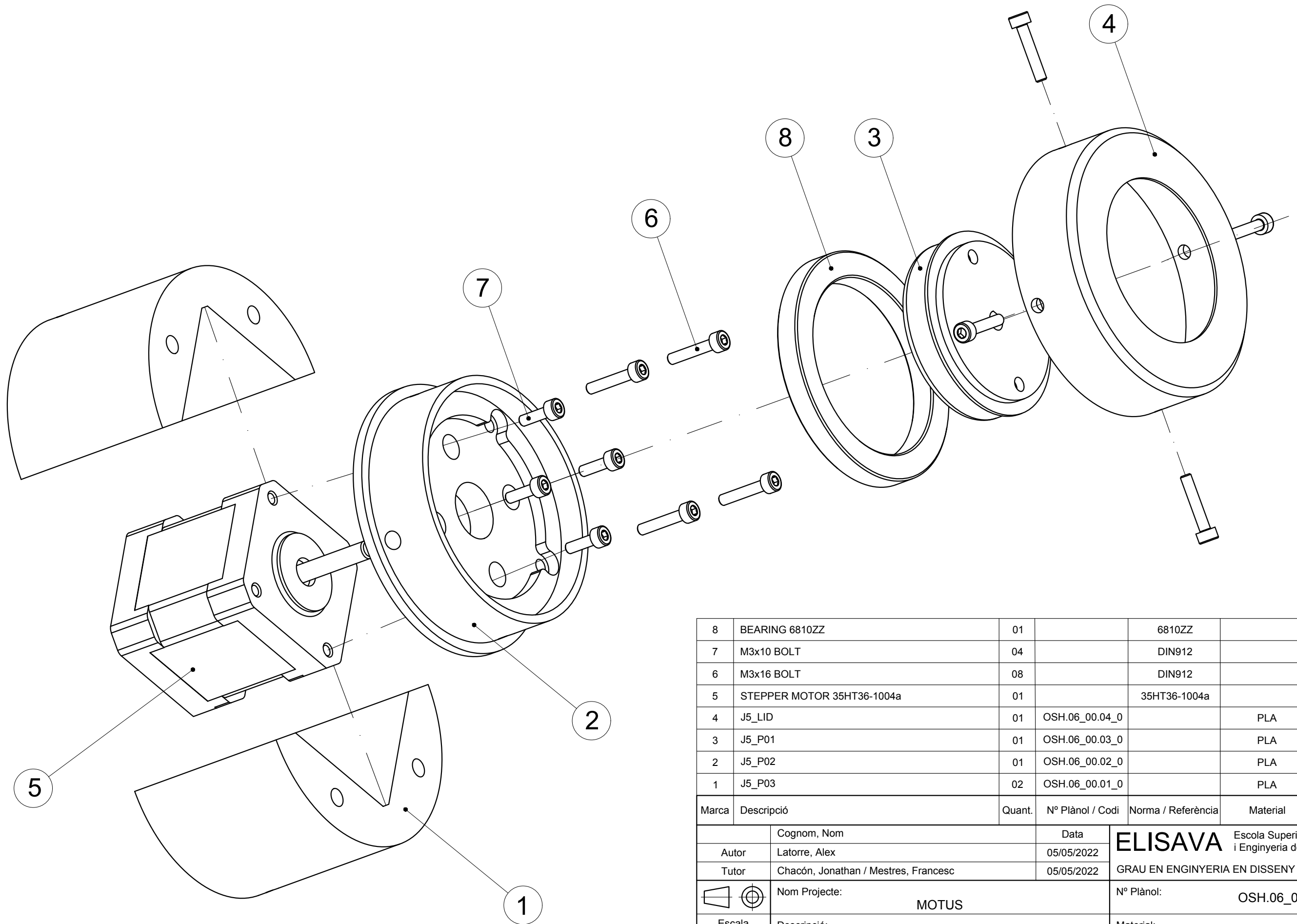

8	BEARING 6810ZZ	01		6810ZZ		- g
7	M3x10 BOLT	04		DIN912		- g
6	M3x16 BOLT	08		DIN912		- g
5	STEPPER MOTOR 35HT36-1004a	01		35HT36-1004a		420 g
4	J5_LID	01	OSH.06_00.04_0		PLA	42 g
3	J5_P01	01	OSH.06_00.03_0		PLA	12 g
2	J5_P02	01	OSH.06_00.02_0		PLA	23 g
1	J5_P03	02	OSH.06_00.01_0		PLA	15 g
Marca	Descripció	Quant.	Nº Plànol / Codi	Norma / Referència	Material	Pes
	Cognom, Nom		Data	ELISAVA Escola Superior de Disseny i Enginyeria de Barcelona		
Autor	Latorre, Alex		05/05/2022	GRAU EN ENGINYERIA EN DISSENY INDUSTRIAL		
Tutor	Chacón, Jonathan / Mestres, Francesc		05/05/2022			
	Nom Projecte:	MOTUS		Nº Plànol:	OSH.06_00.00_B	
Escala 1:1	Descripció:	J5 EXP.		Material:	-	
Pes 512 g				Tractament / Acabat:	-	

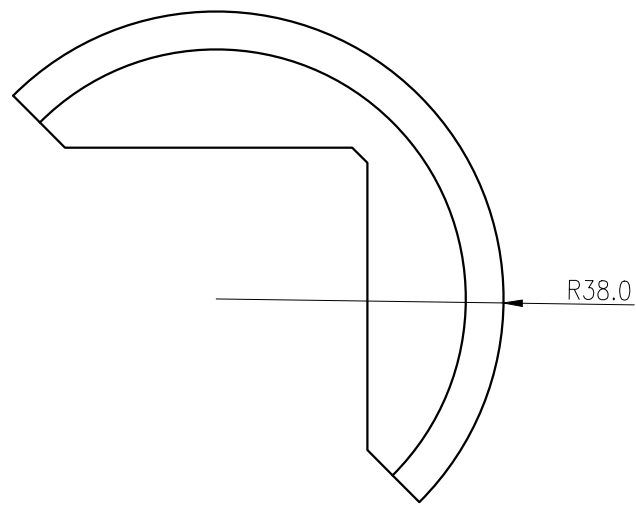

PRINT ORIENTATION

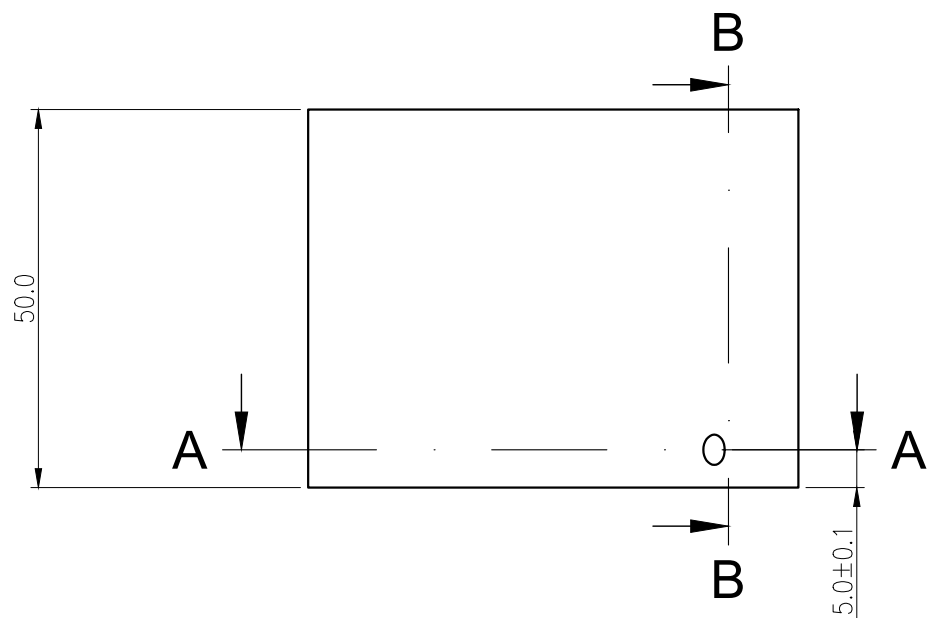
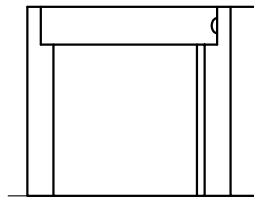

B-B (1:1)

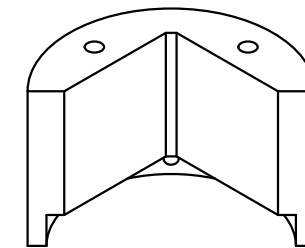
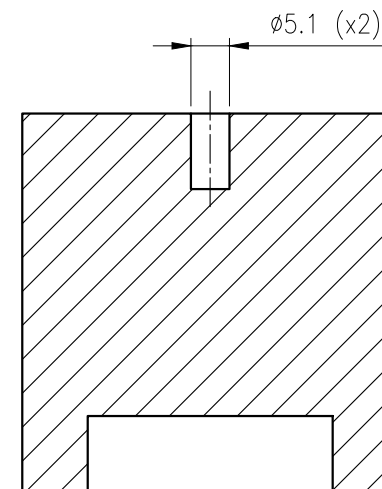

SCALE 1:2

A-A (1:1)

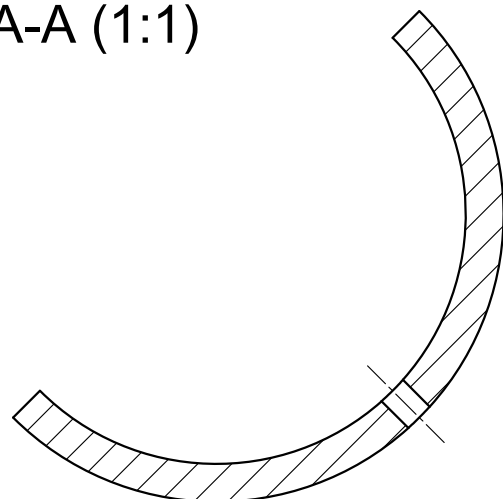

Printing Parameters	
Material	PLA
Extruder Diameter	0.4 mm
Layer Height	0.2 mm
Shell Thickness	1 mm
Infill	20%
Extruder Temperature	220 °C
Bed Temperature	60 °C
Supports	N

	Cognom, Nom	Data	ELISAVA Escola Superior de Disseny i Enginyeria de Barcelona
Autor	Latorre, Alex	05/05/2022	
Tutor	Chacón, Jonathan / Mestres, Francesc	05/05/2022	GRAU EN ENGINYERIA EN DISSENY INDUSTRIAL
	Nom Projecte:	MOTUS	Nº Plànol: OSH.06_00.01_0
Escala 1:1	Descripció:	J5_P03	Material: PLA
Pes 15 g			Tractament / Acabat: -

C-C (1:1)

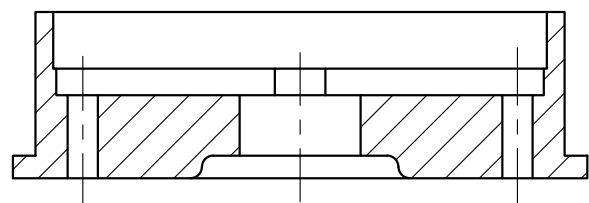

PRINT ORIENTATION

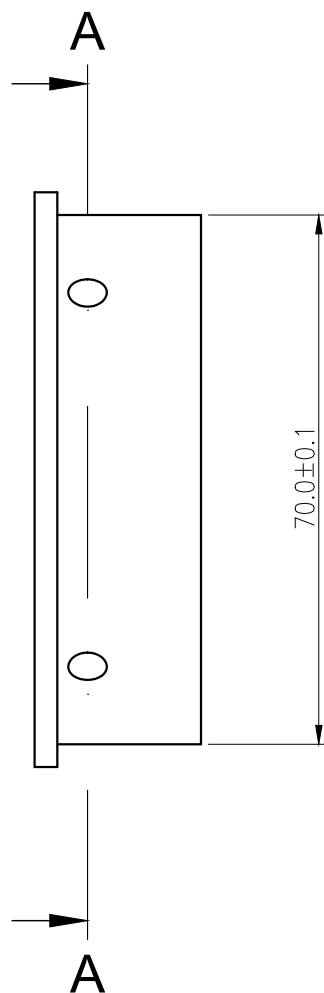
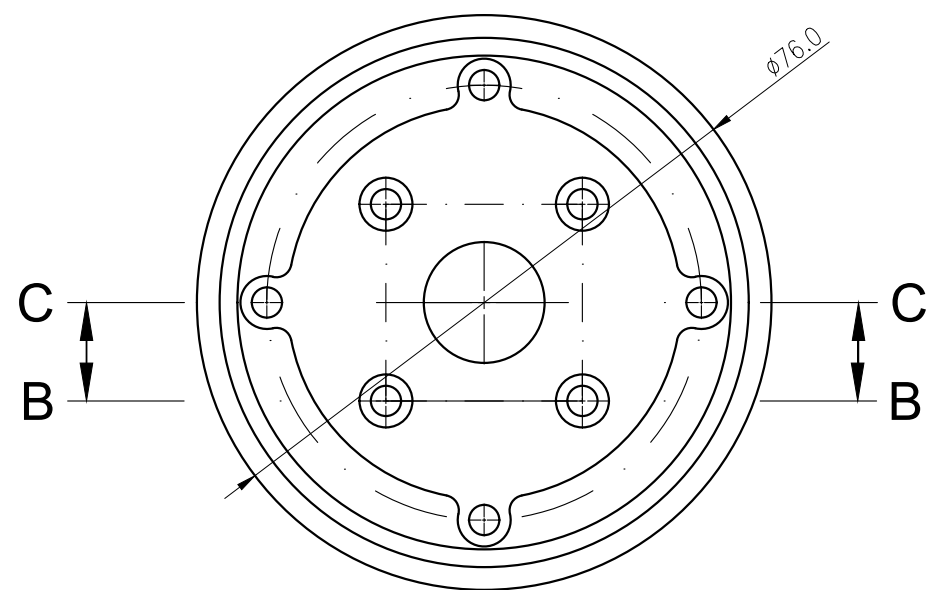
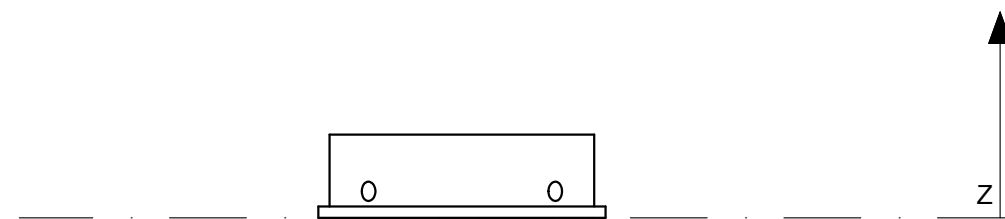

A-A (1:1)

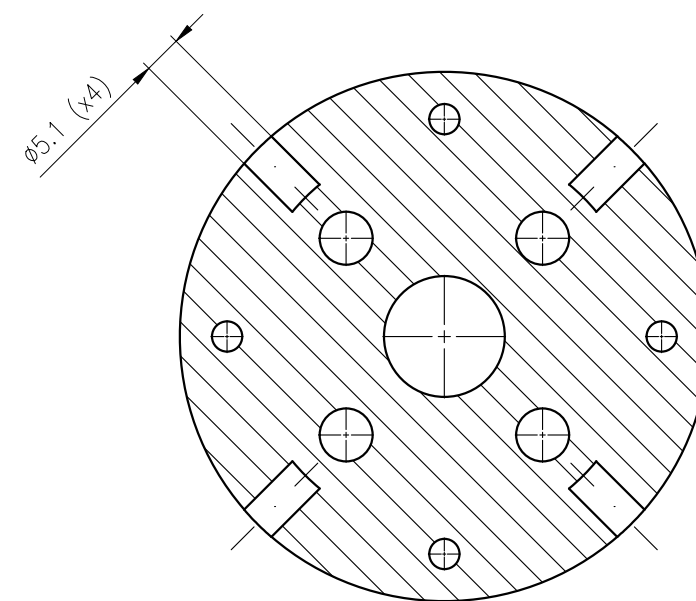

B-B (1:1)

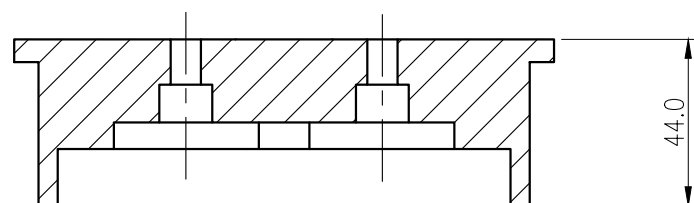

Printing Parameters	
Material	PLA
Extruder Diameter	0.4 mm
Layer Height	0.2 mm
Shell Thickness	1 mm
Infill	20%
Extruder Temperature	220 °C
Bed Temperature	60 °C
Supports	N

	Cognom, Nom	Data	ELISAVA Escola Superior de Disseny i Enginyeria de Barcelona GRAU EN ENGINYERIA EN DISSENY INDUSTRIAL
Autor	Latorre, Alex	05/05/2022	
Tutor	Chacón, Jonathan / Mestres, Francesc	05/05/2022	Nº Plànol: OSH.06_00.02_0
	Nom Projecte:	MOTUS	Material: PLA
Escala 1:1 Pes 23 g	Descripció:	J5_P02	Tractament / Acabat: -

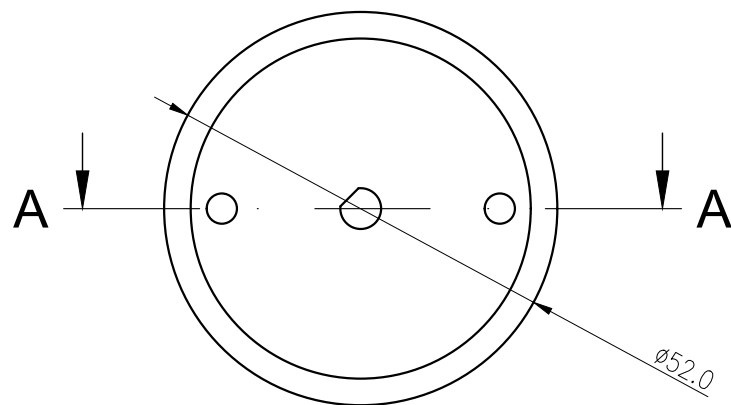

A-A (1:1)

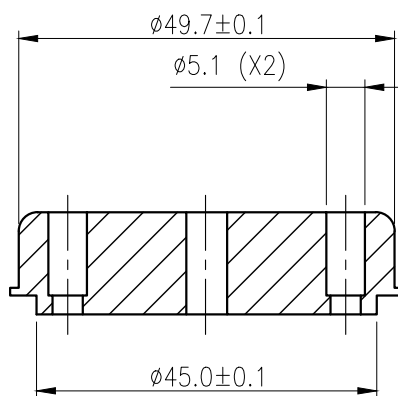

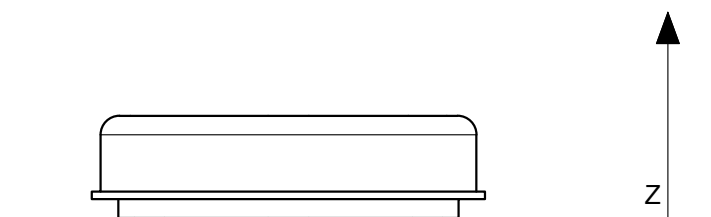

PRINT ORIENTATION



Printing Parameters

Material	PLA
Extruder Diameter	0.4 mm
Layer Height	0.2 mm
Shell Thickness	1 mm
Infill	20%
Extruder Temperature	220 °C
Bed Temperature	60 °C
Supports	Y

	Cognom, Nom	Data	ELISAVA Escola Superior de Disseny i Enginyeria de Barcelona GRAU EN ENGINYERIA EN DISSENY INDUSTRIAL
Autor	Latorre, Alex	05/05/2022	
Tutor	Chacón, Jonathan / Mestres, Francesc	05/05/2022	
 	Nom Projecte:	MOTUS	Nº Plànol: OSH.06_00.03_0
Escala 1:2	Descripció:	J5_P01	Material: PLA
Pes 12 g			Tractament / Acabat: -

PRINT ORIENTATION

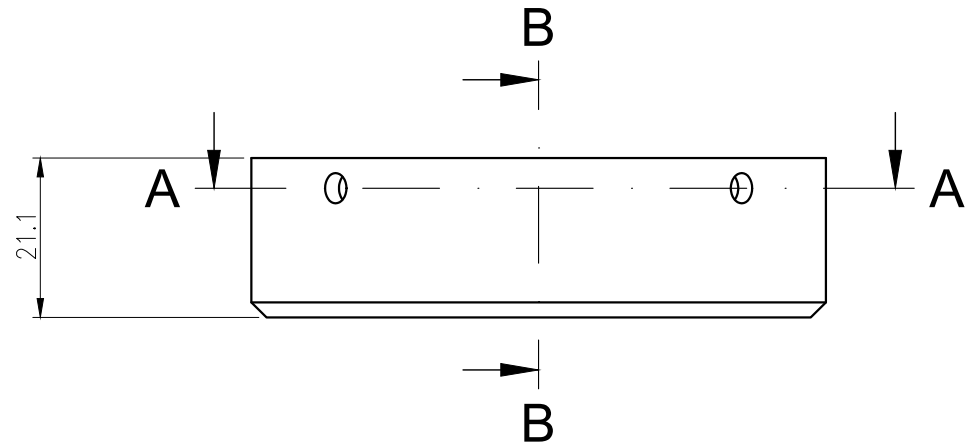
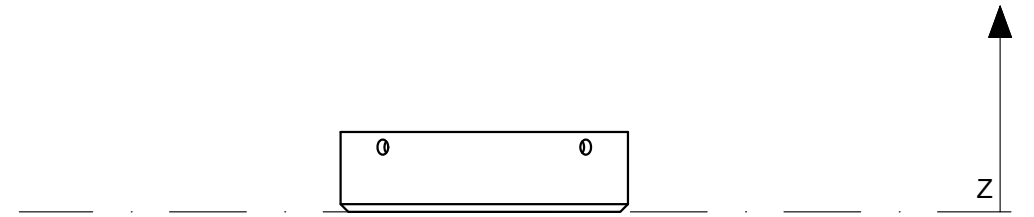

B-B (1:1)

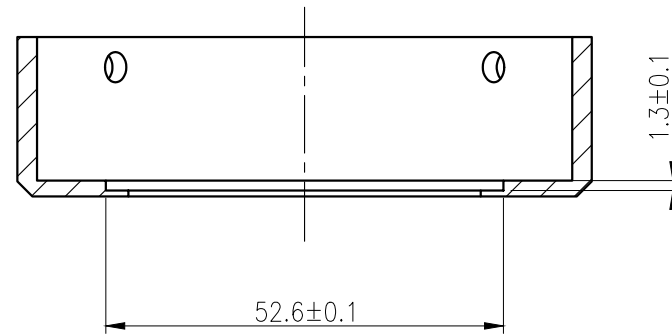

A-A (1:1)

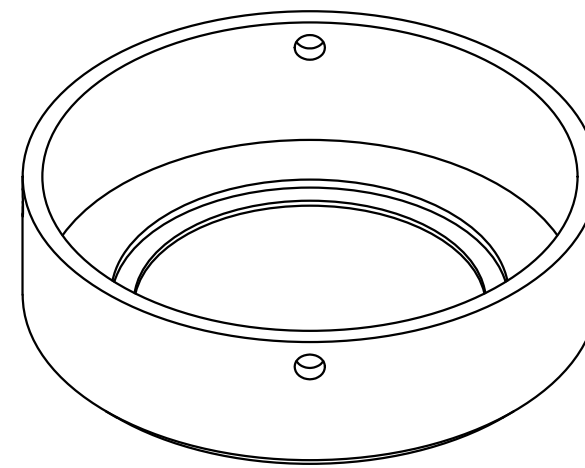
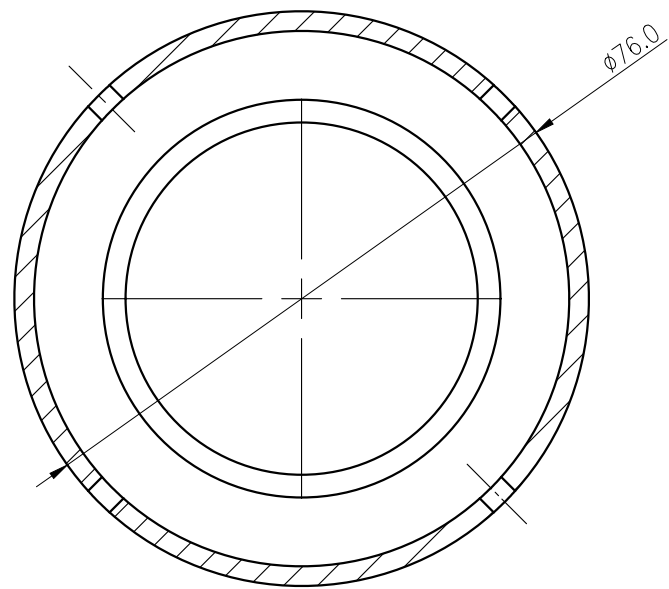



SCALE 1:1

Printing Parameters

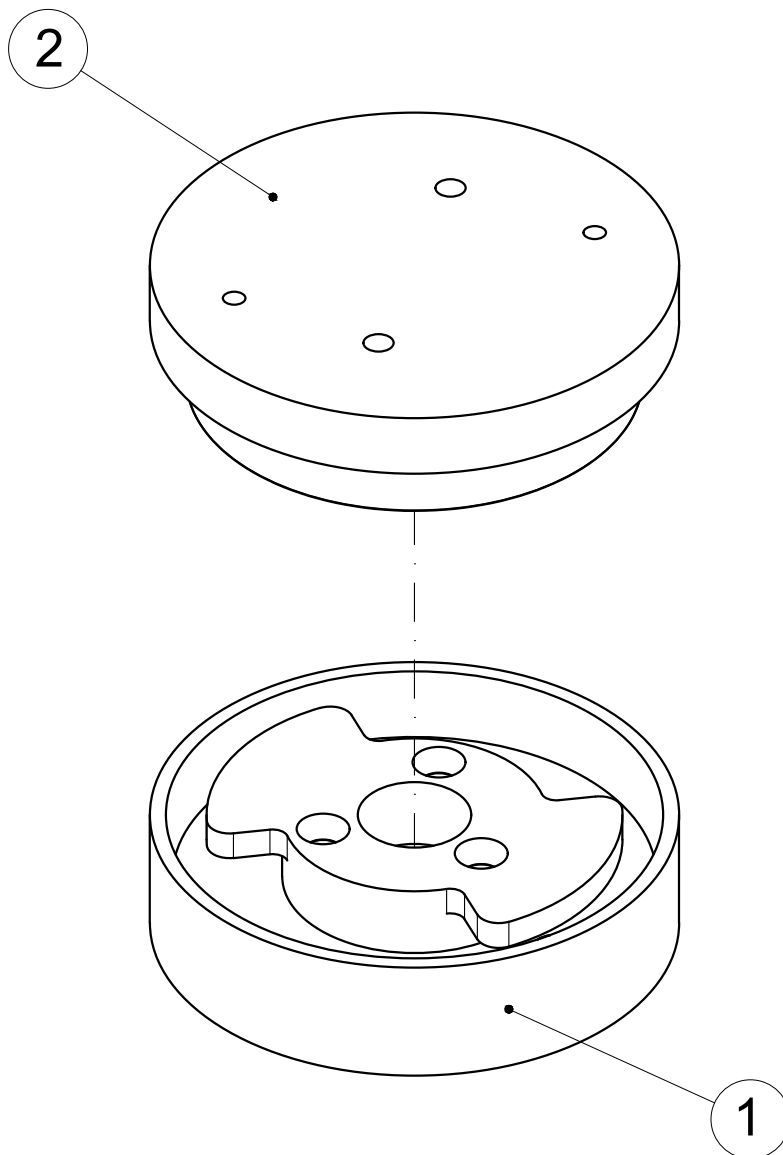

Material	PLA
Extruder Diameter	0.4 mm
Layer Height	0.2 mm
Shell Thickness	1 mm
Infill	20%
Extruder Temperature	220 °C
Bed Temperature	60 °C
Supports	N

Cognom, Nom			Data		
Autor	Latorre, Alex		05/05/2022		
Tutor	Chacón, Jonathan / Mestres, Francesc		05/05/2022	ELISAVA Escola Superior de Disseny i Enginyeria de Barcelona GRAU EN ENGINYERIA EN DISSENY INDUSTRIAL	
Nom Projecte:	MOTUS		Nº Plànol:	OSH.06_00.04_0	
Descripció:	J5_LID		Material:	PLA	
Escala 1:1 Pes 42 g			Tractament / Acabat:	-	

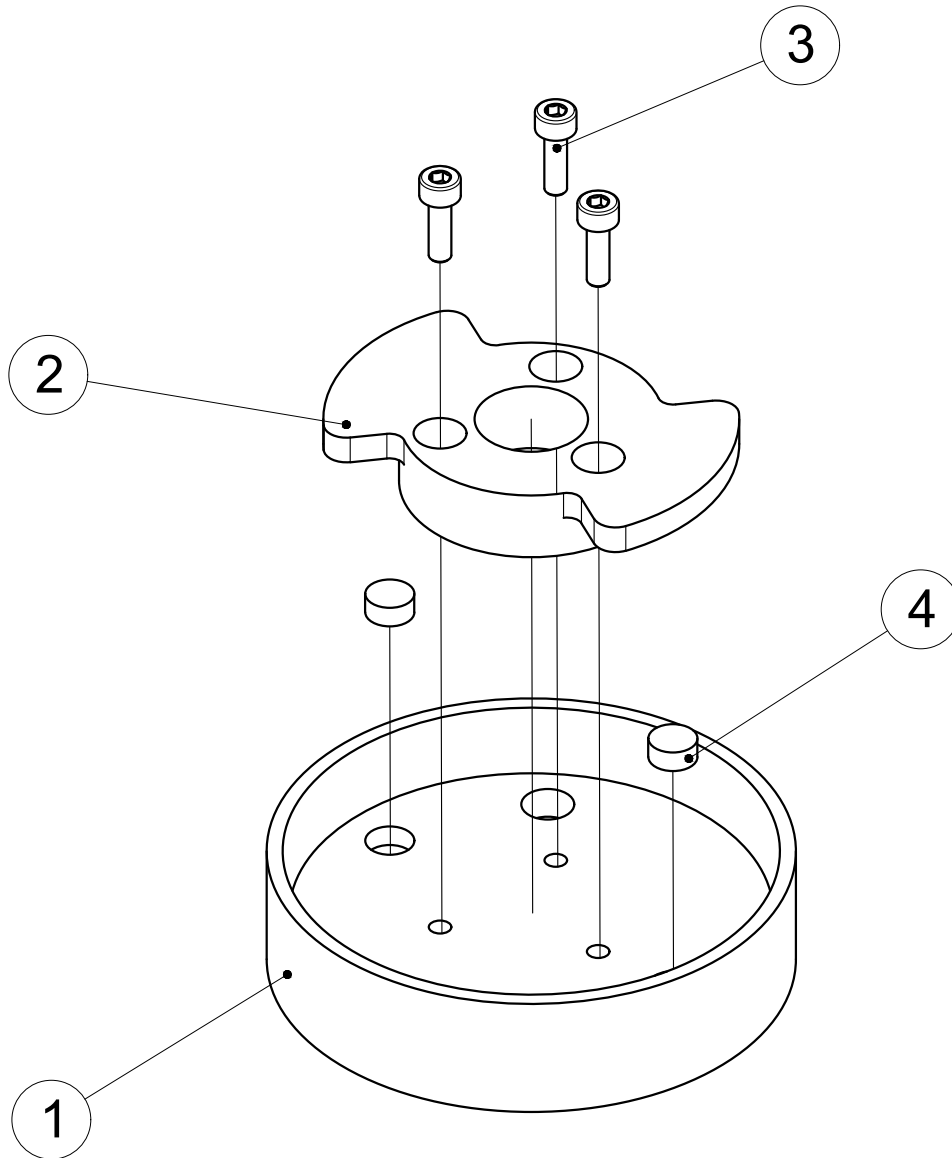

2	QC_PART2	01	OSH.07_02.00_0		-	20 g
1	QC_PART2	01	OSH.07_01.00_0		-	23 g
Marca	Descripció	Quant.	Nº Plànol / Codi	Norma / Referència	Material	Pes
	Cognom, Nom		Data	ELISAVA Escola Superior de Disseny i Enginyeria de Barcelona GRAU EN ENGINYERIA EN DISSENY INDUSTRIAL		
Autor	Latorre, Alex		05/05/2022			
Tutor	Chacón, Jonathan / Mestres, Francesc		05/05/2022			
		Nom Projecte: MOTUS		Nº Plànol:	OSH.07_00.00_0	
Escala 1:1	Descripció: QC		Material: -			
Pes 43 g			Tractament / Acabat:			



4	6x3 MAGNET	02		B075FL7FVS		- g
3	M3x10 BOLT	03		DIN912		- g
2	QC_02	01	OSH.07_01.02_0		PLA	6 g
1	QC_01	01	OSH.07_01.01_0		PLA	17 g
Marca	Descripció	Quant.	Nº Plànol / Codi	Norma / Referència	Material	Pes
	Cognom, Nom		Data	ELISAVA Escola Superior de Disseny i Enginyeria de Barcelona GRAU EN ENGINYERIA EN DISSENY INDUSTRIAL		
Autor	Latorre, Alex		05/05/2022			
Tutor	Chacón, Jonathan / Mestres, Francesc		05/05/2022			
 	Nom Projecte:	MOTUS		Nº Plànol:	OSH.07_01.00_0	
Escala 1:1	Descripció:	QC_PART1		Material:	PLA	
Pes 23 g				Tractament / Acabat:		

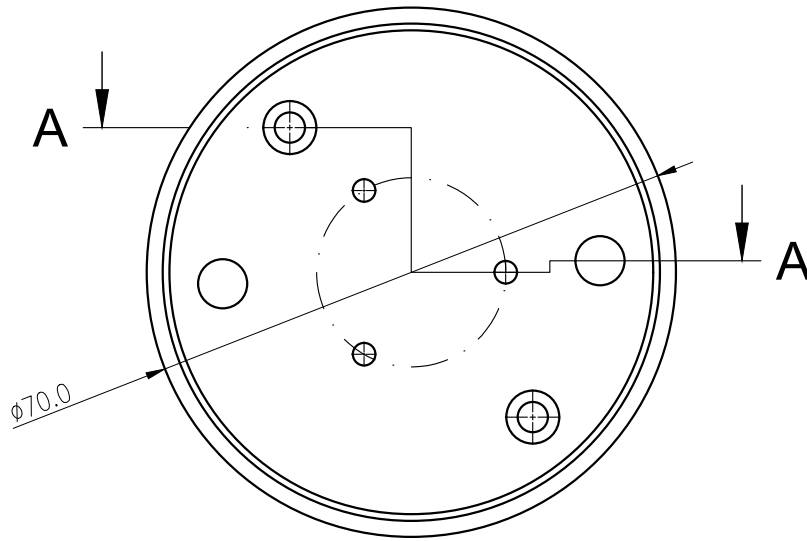

A-A (1:1)

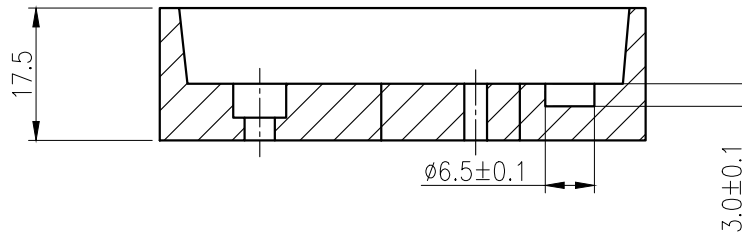

PRINT ORIENTATION

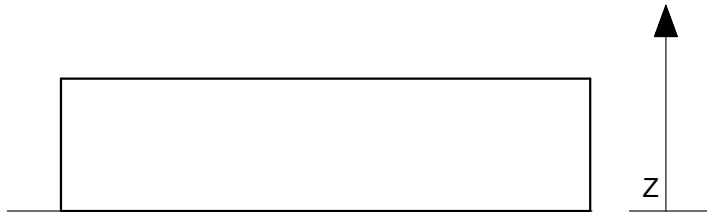

Printing Parameters

Material	PLA
Extruder Diameter	0.4 mm
Layer Height	0.2 mm
Shell Thickness	1 mm
Infill	20%
Extruder Temperature	220 °C
Bed Temperature	60 °C
Supports	N

	Cognom, Nom	Data	ELISAVA Escola Superior de Disseny i Enginyeria de Barcelona GRAU EN ENGINYERIA EN DISSENY INDUSTRIAL
Autor	Latorre, Alex	05/05/2022	
Tutor	Chacón, Jonathan / Mestres, Francesc	05/05/2022	
	Nom Projecte:	MOTUS	Nº Plànol: OSH.07_01.01_0
Escala 1:1	Descripció:	QC_01	Material: PLA
Pes 17 g			Tractament / Acabat: -

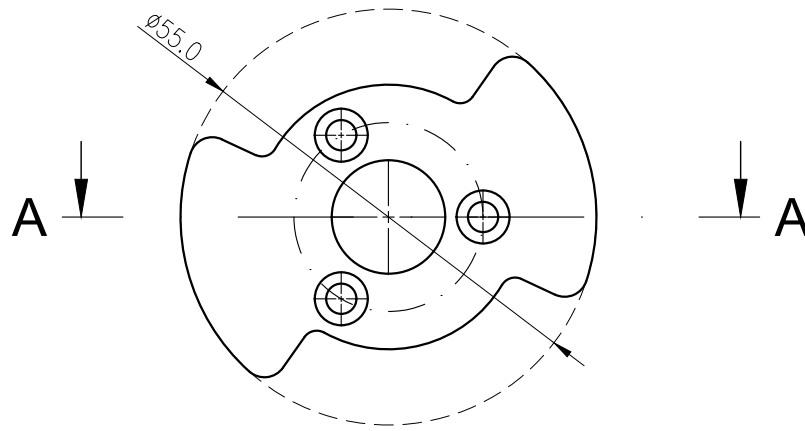

A-A (1:1)

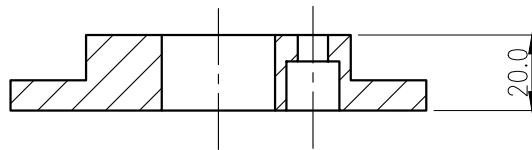

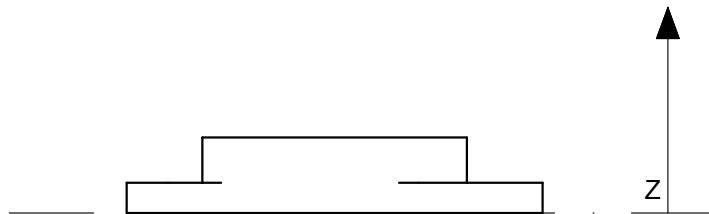

PRINT ORIENTATION



Printing Parameters

Material	PLA
Extruder Diameter	0.4 mm
Layer Height	0.2 mm
Shell Thickness	1 mm
Infill	20%
Extruder Temperature	220 °C
Bed Temperature	60 °C
Supports	N

	Cognom, Nom	Data	ELISAVA Escola Superior de Disseny i Enginyeria de Barcelona GRAU EN ENGINYERIA EN DISSENY INDUSTRIAL
Autor	Latorre, Alex	05/05/2022	
Tutor	Chacón, Jonathan / Mestres, Francesc	05/05/2022	
 	Nom Projecte:	MOTUS	Nº Plànol: OSH.07_01.02_0
Escala 1:1	Descripció:	QC_02	Material: PLA
Pes 6 g			Tractament / Acabat: -

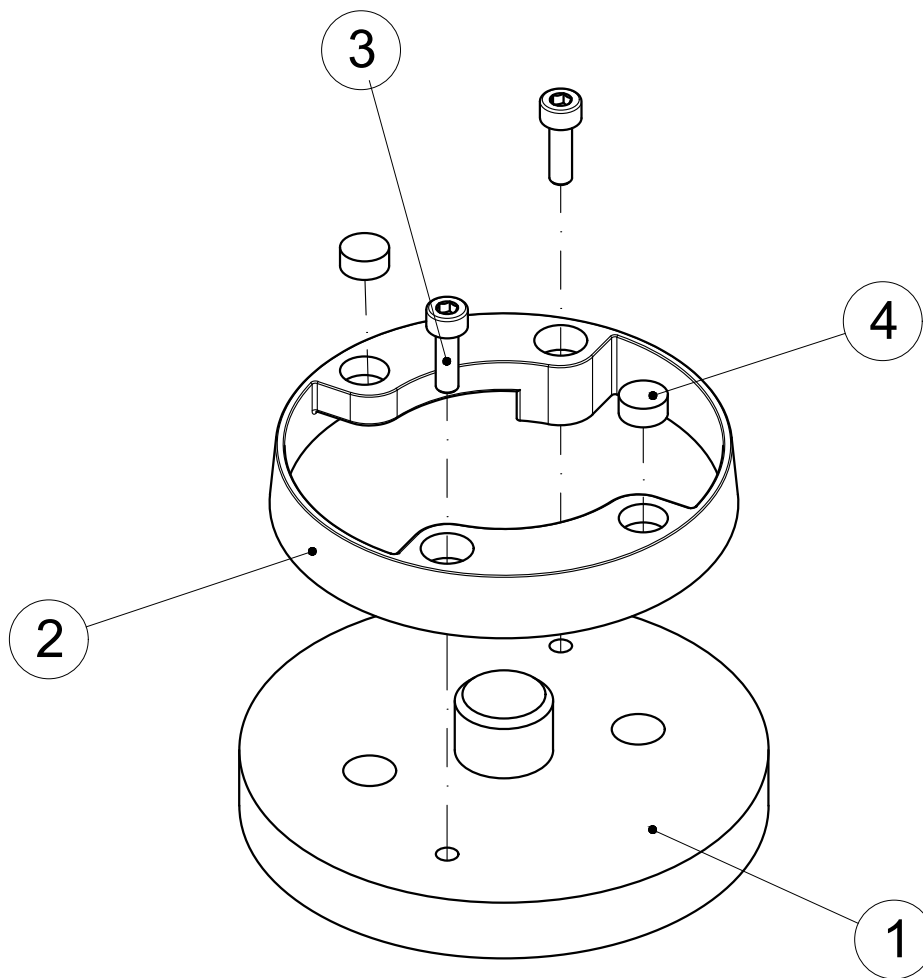

4	6x3 MAGNET	02		B075FL7FVS		- g
3	M3x10 BOLT	02		DIN912		- g
2	QC_04	01	OSH.07_02.02_0		PLA	6 g
1	QC_03	01	OSH.07_02.01_0		PLA	14 g
Marca	Descripció	Quant.	Nº Plànol / Codi	Norma / Referència	Material	Pes
	Cognom, Nom		Data	ELISAVA Escola Superior de Disseny i Enginyeria de Barcelona		
Autor	Latorre, Alex		05/05/2022	GRAU EN ENGINYERIA EN DISSENY INDUSTRIAL		
Tutor	Chacón, Jonathan / Mestres, Francesc		05/05/2022	Nº Plànol:	OSH.07_02.00_0	
Escala 1:1	Nom Projecte:	MOTUS		Material:	PLA	
	Descripció:	QC_PART2		Tractament / Acabat:		
Pes 20 g						

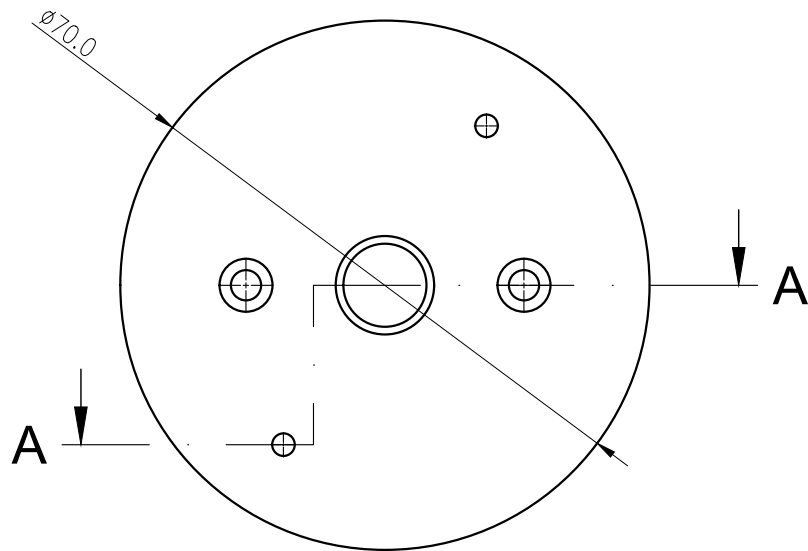

A-A (1:1)

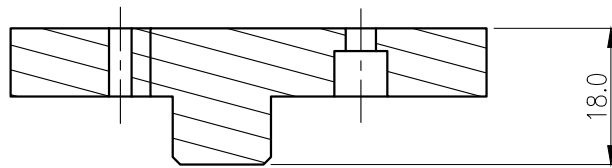

PRINT ORIENTATION

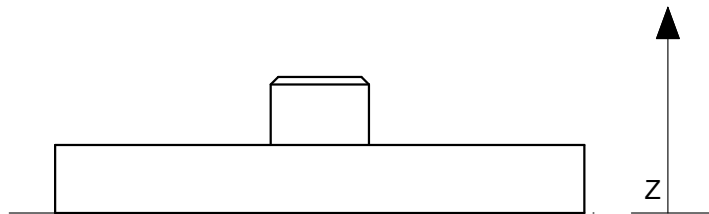

Printing Parameters

Material	PLA
Extruder Diameter	0.4 mm
Layer Height	0.2 mm
Shell Thickness	1 mm
Infill	20%
Extruder Temperature	220 °C
Bed Temperature	60 °C
Supports	N

	Cognom, Nom	Data	ELISAVA Escola Superior de Disseny i Enginyeria de Barcelona GRAU EN ENGINYERIA EN DISSENY INDUSTRIAL
Autor	Latorre, Alex	05/05/2022	
Tutor	Chacón, Jonathan / Mestres, Francesc	05/05/2022	
	Nom Projecte:	MOTUS	Nº Plànol: OSH.07_02.01_0
Escala 1:1	Descripció:	QC_03	Material: PLA
Pes 14 g			Tractament / Acabat: -

B-B (1:1)

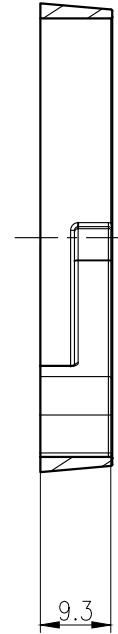
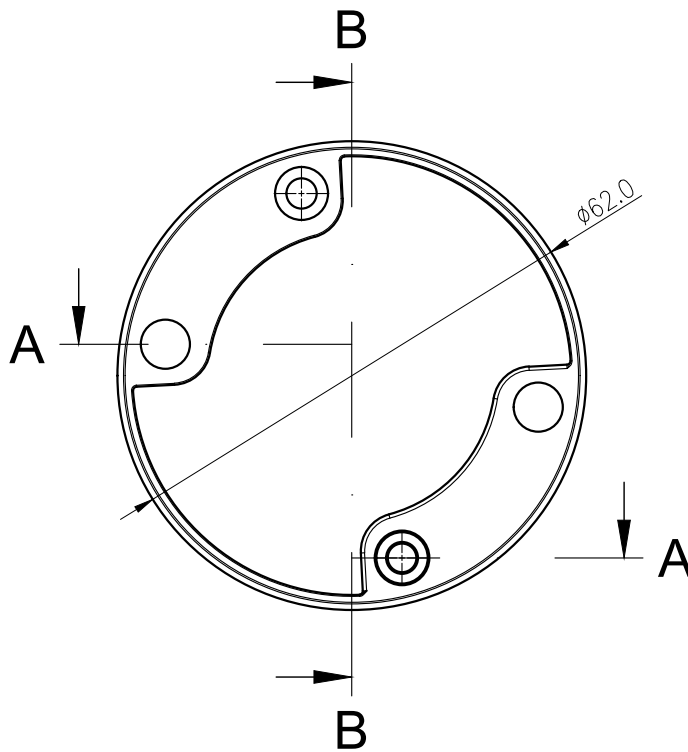

A-A (1:1)

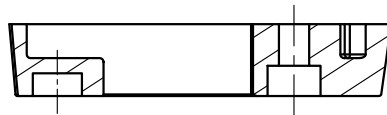

PRINT ORIENTATION



Printing Parameters

Material	PLA
Extruder Diameter	0.4 mm
Layer Height	0.2 mm
Shell Thickness	1 mm
Infill	20%
Extruder Temperature	220 °C
Bed Temperature	60 °C
Supports	N

	Cognom, Nom	Data	ELISAVA Escola Superior de Disseny i Enginyeria de Barcelona
Autor	Latorre, Alex	05/05/2022	
Tutor	Chacón, Jonathan / Mestres, Francesc	05/05/2022	GRAU EN ENGINYERIA EN DISSENY INDUSTRIAL
	Nom Projecte:	MOTUS	Nº Plànol: OSH.07_02.02_0
Escala 1:1	Descripció:	QC_04	Material: PLA
Pes 6 g			Tractament / Acabat: -