

Hardware for Soap Film Tunnel

50 small bolts with nuts

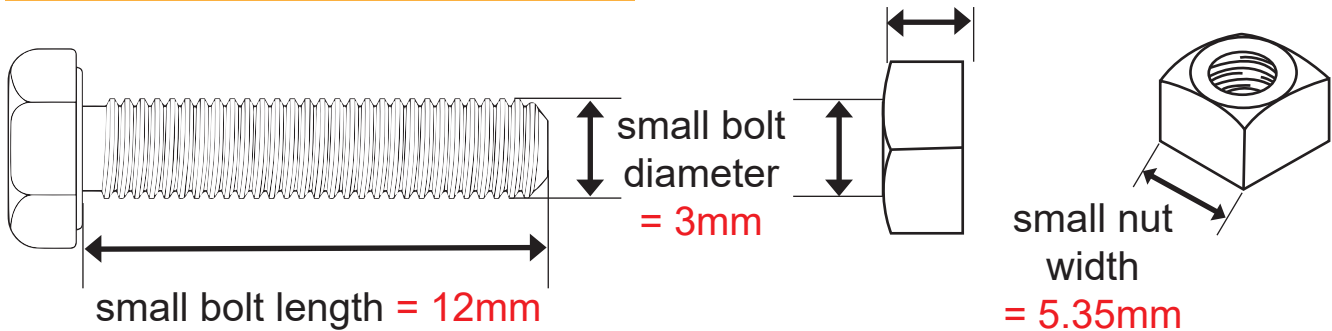

8 medium bolts with nuts

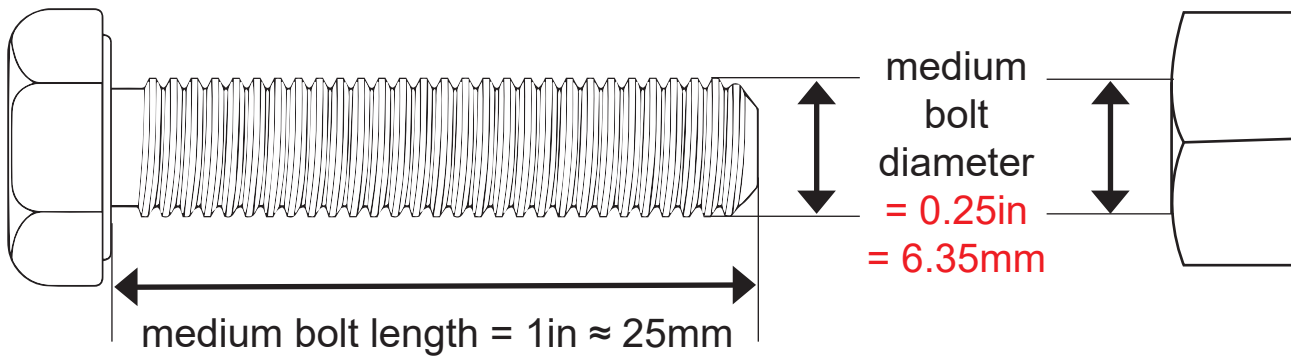

2 long bolt with 4 nuts

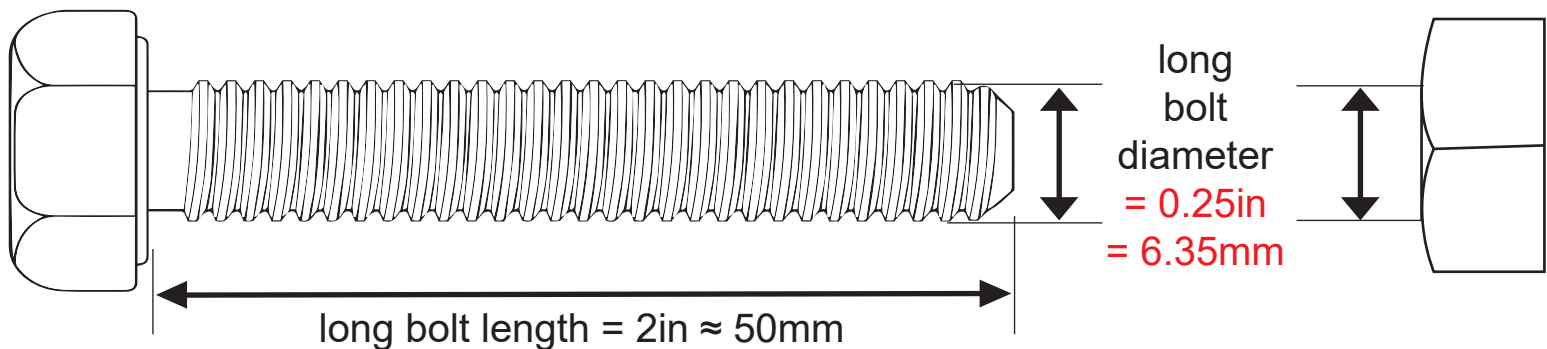

If you use hardware of different sizes make sure to update the SOLIDWORKS assembly for any change of the dimensions in red so that your laser cut frame will fit.

Also make sure your hardware meets these constraints:

- (1) small bolt length - small nut height - thickness of wood > 3mm
- (2) thickness of wood - small bolt diameter > 3mm
- (3) small nut width \approx thickness of wood
- (4) medium bolt length - 3X (thickness of wood) > 5mm
- (5) Long bolt length - valve length - 2X (thickness of wood) - bolt height > 3mm

valve length = 55mm for the valve we used

See image to the right to see how long bolt must be

