

# Master Controller Scissor Prop

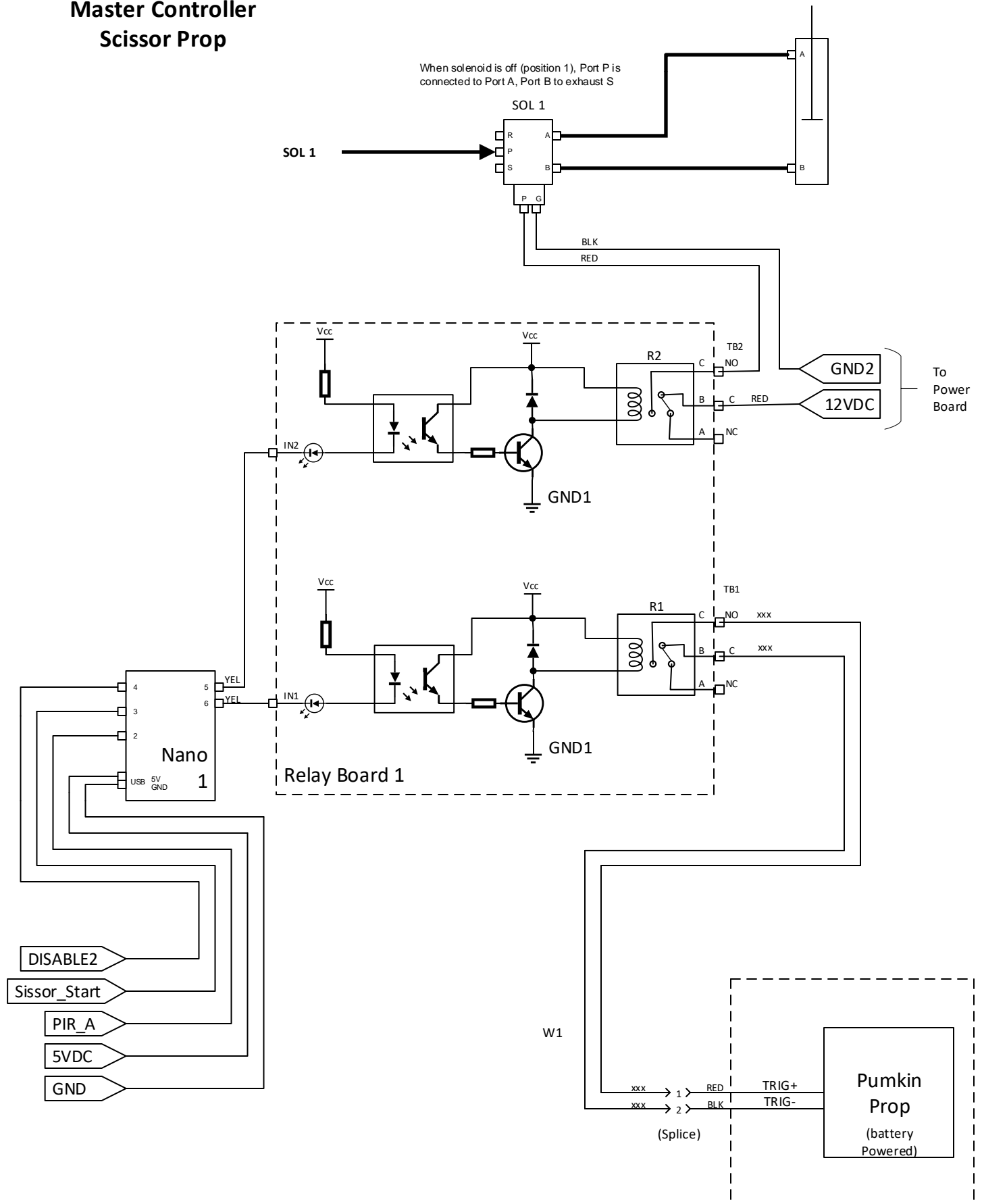

# Master Controller Witch Pop Up Prop

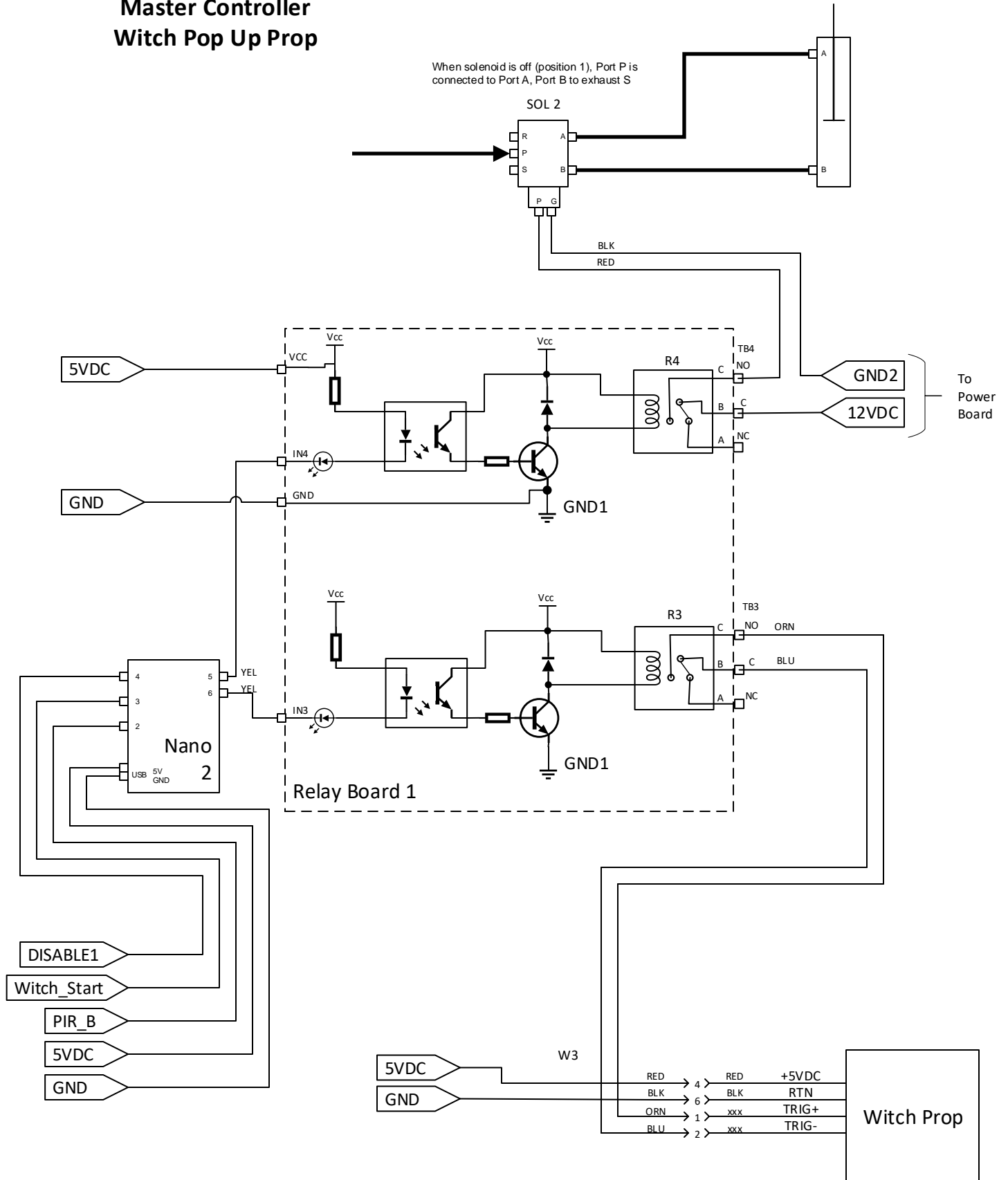

# Master Controller Dragon Prop

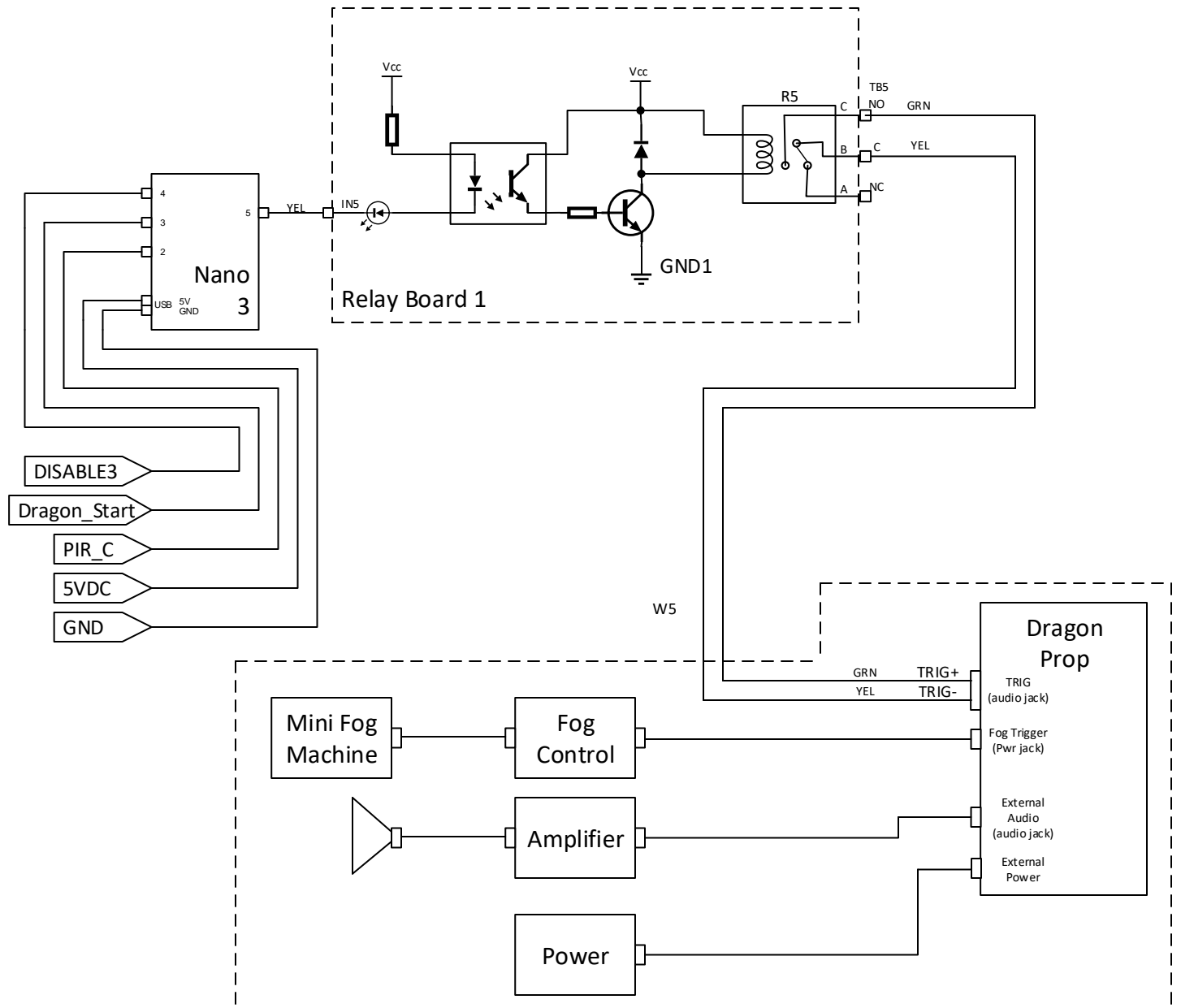



# Master Controller

## Knights

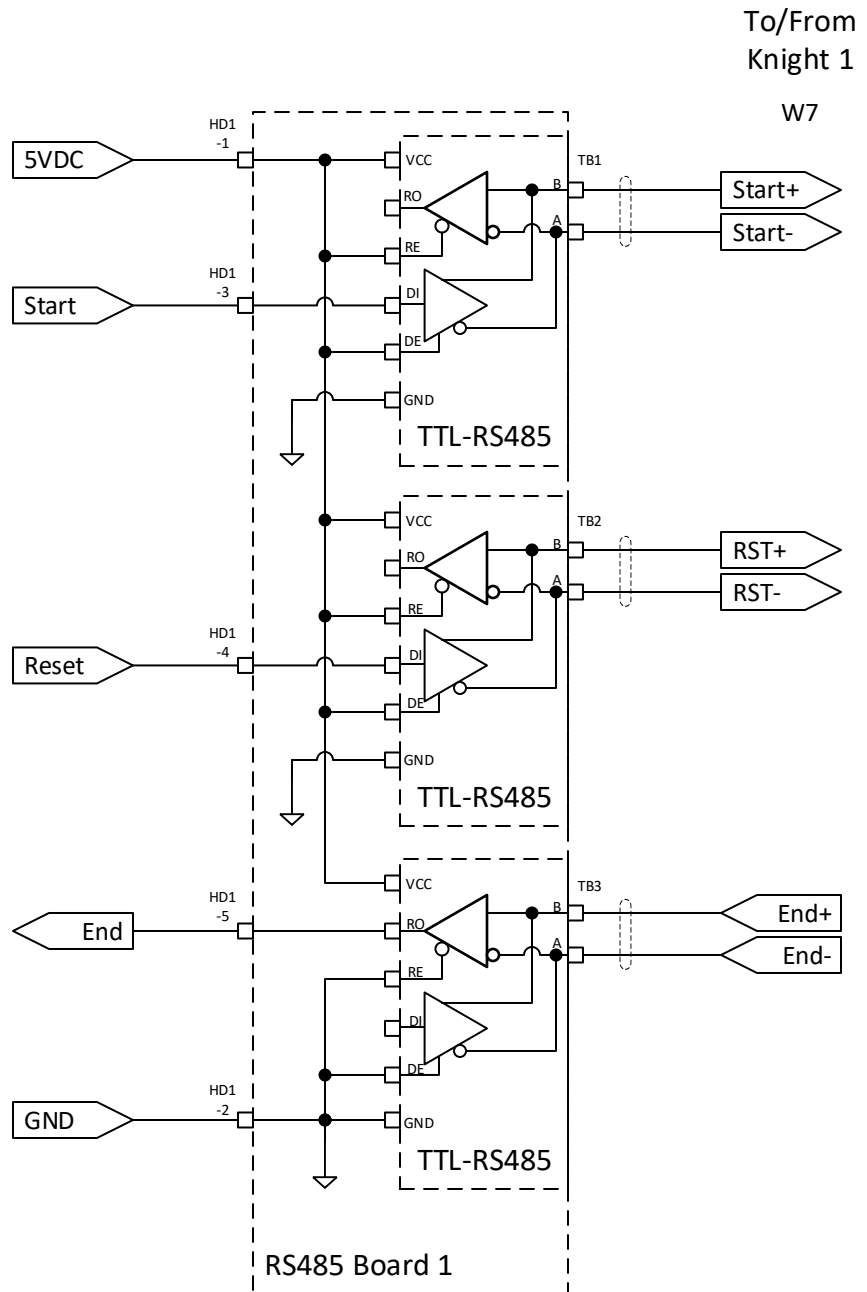

# Master Controller

## Knights

To/From  
Knight 2

W8

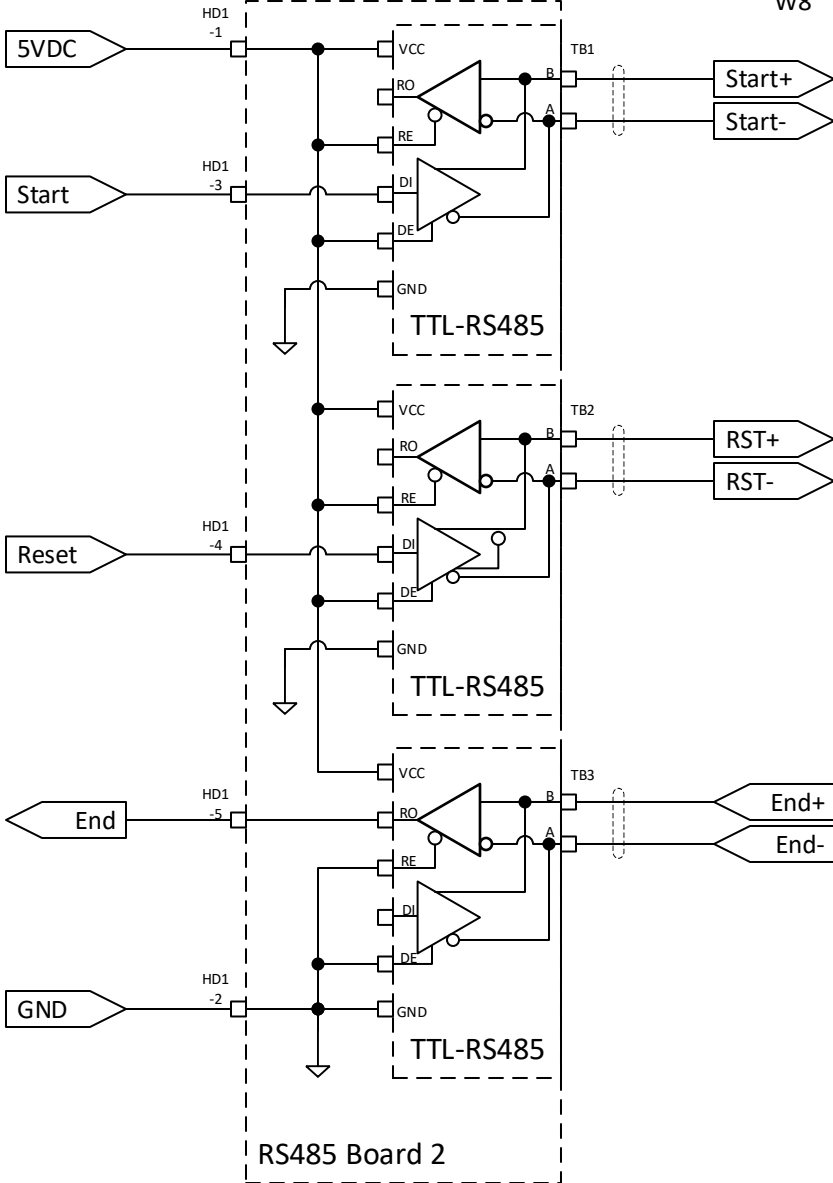

# Master Controller

## Power & Control

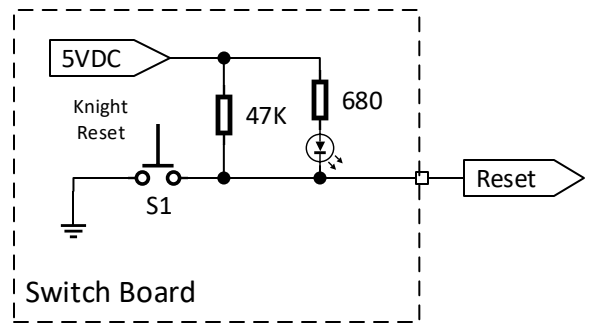
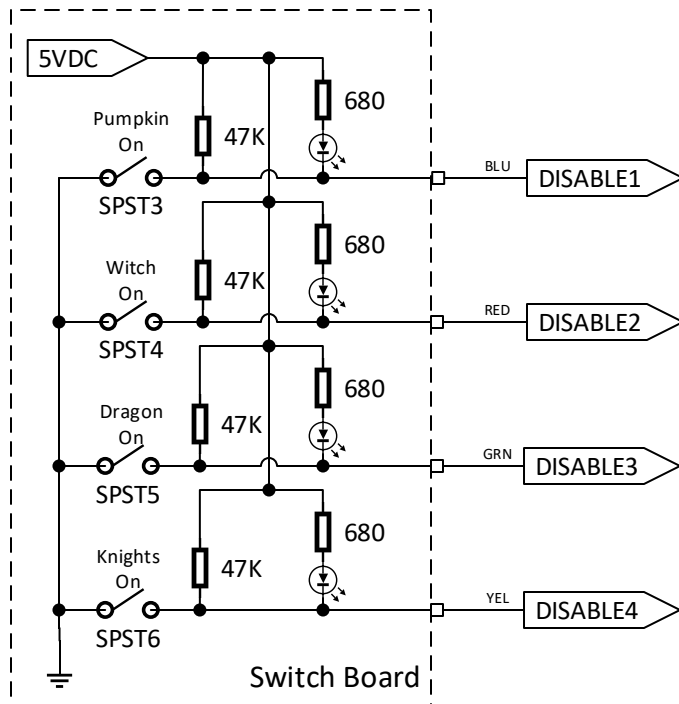
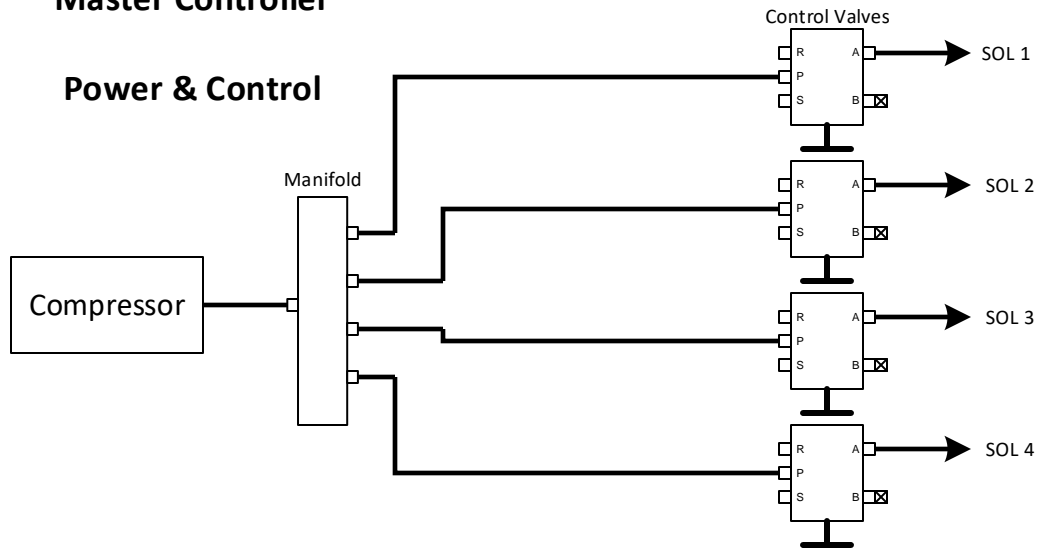

## Main Power

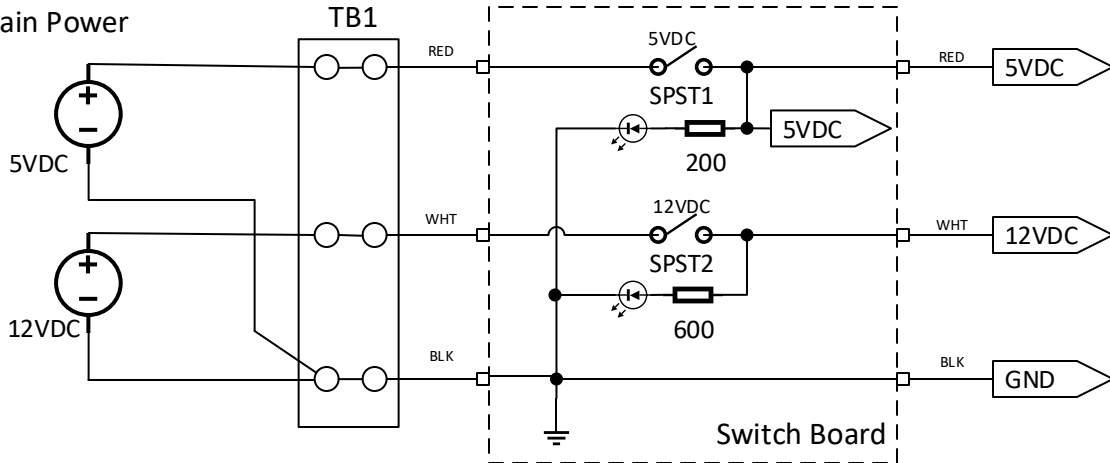



# Master Controller Power Distribution

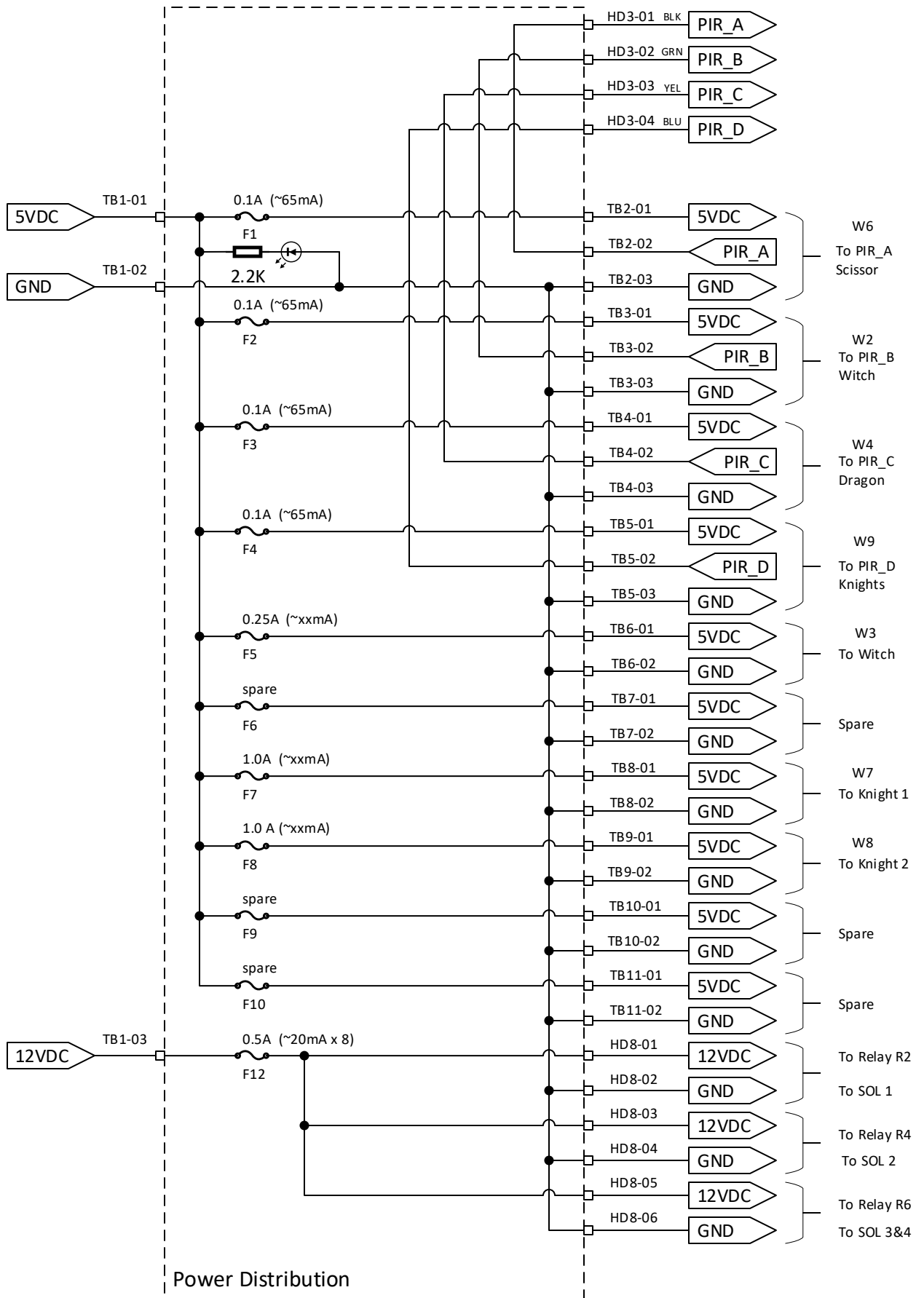

# Master Controller Power Distribution

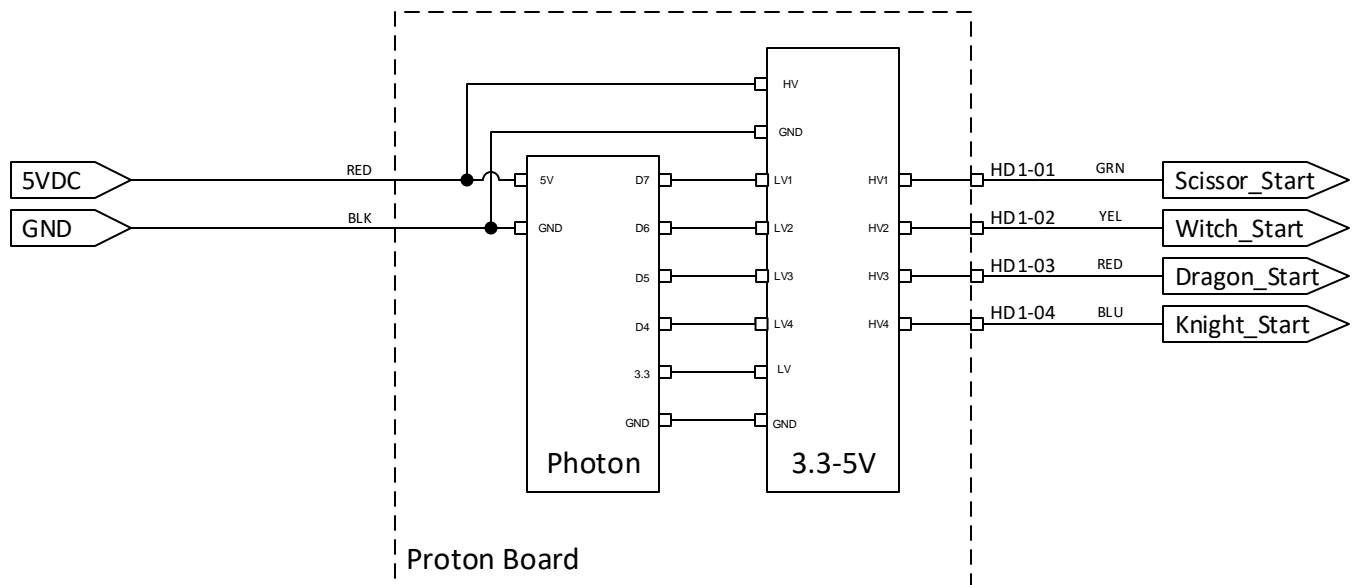
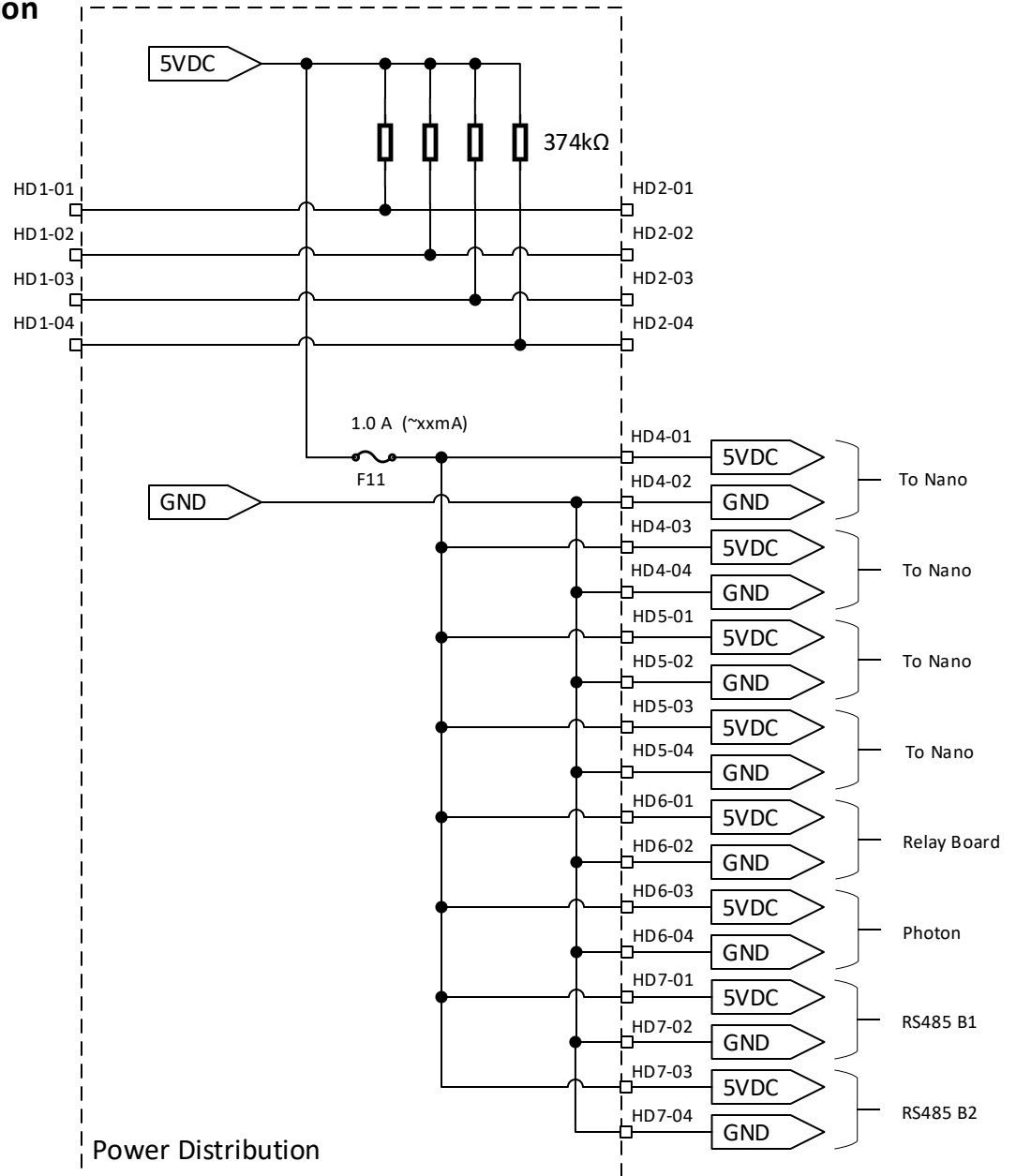

# Master Controller

## Remote Cabling & Sensors

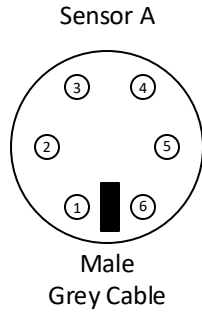

PIN	Cable	Function
1	N/C	N/C
2	ORN	N/C
3	N/C	N/C
4	BRN	PWR
5	RED	OUT
6	BLK	GND

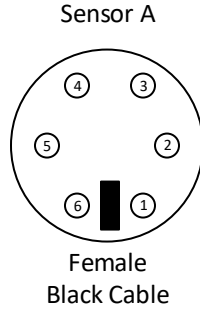

PIN	CABLE	Ex Cbl	Function
1	N/C	N/C	N/C
2	BRN	N/C	N/C
3	N/C	N/C	N/C
4	RED	RED	PWR
5	ORN	YEL	OUT
6	BLK	BLK	GND

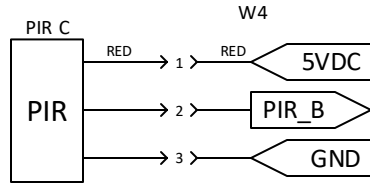

**Witch Pop Up Sensor**

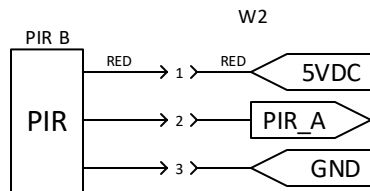

**Scissor Sensor**

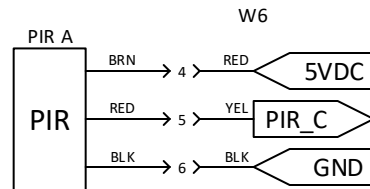

**Dragon Sensor**

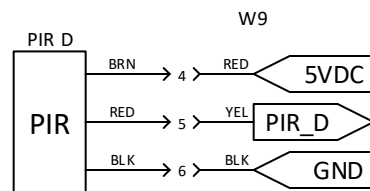

**Knight Sensor**

### PIR Sensor connectors

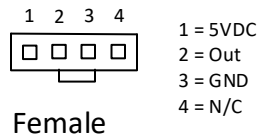
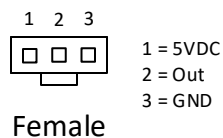

# Knights

## Remote Controller

### Knigh 1

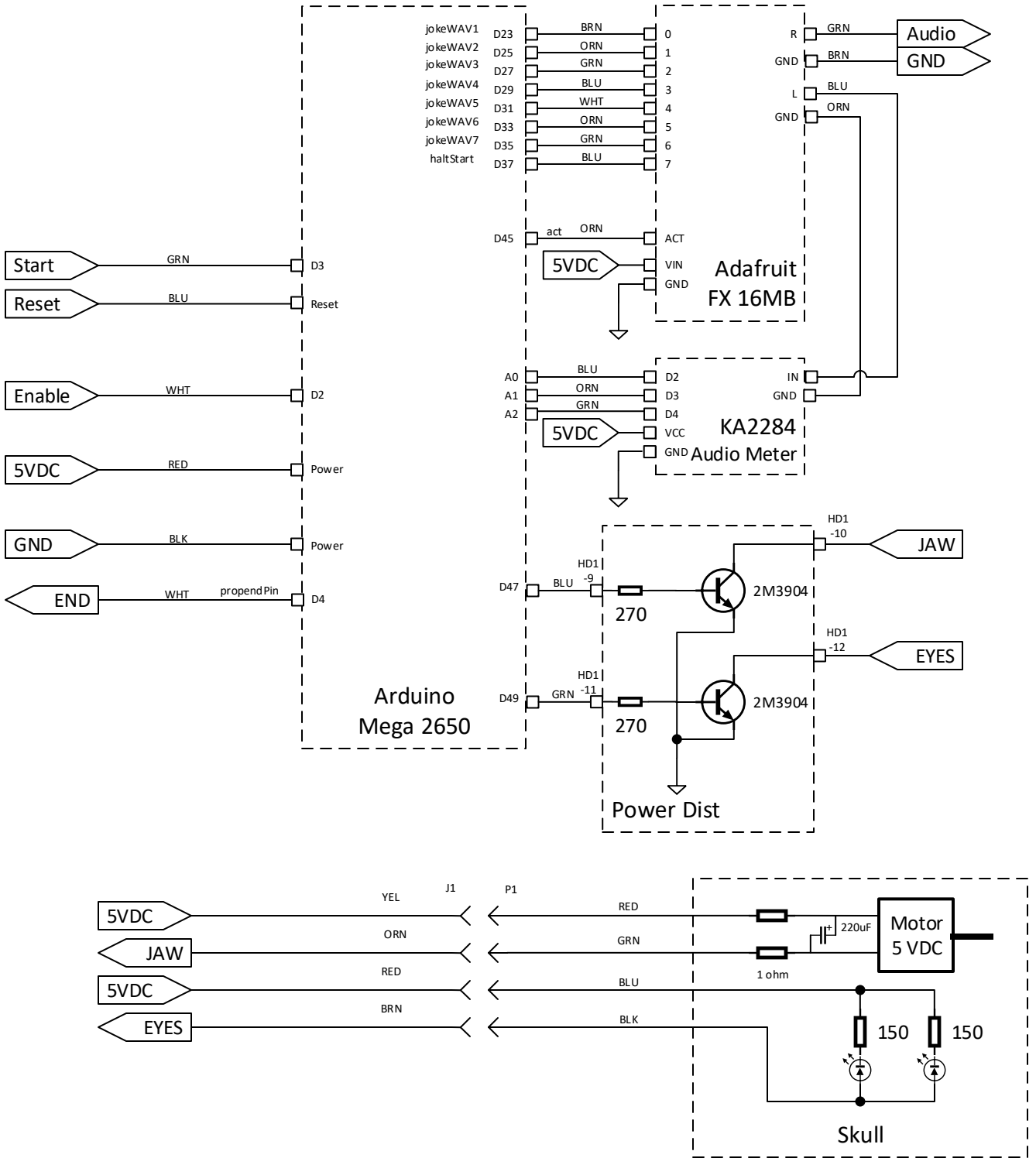

# Knight Remote Controller

Knight 1

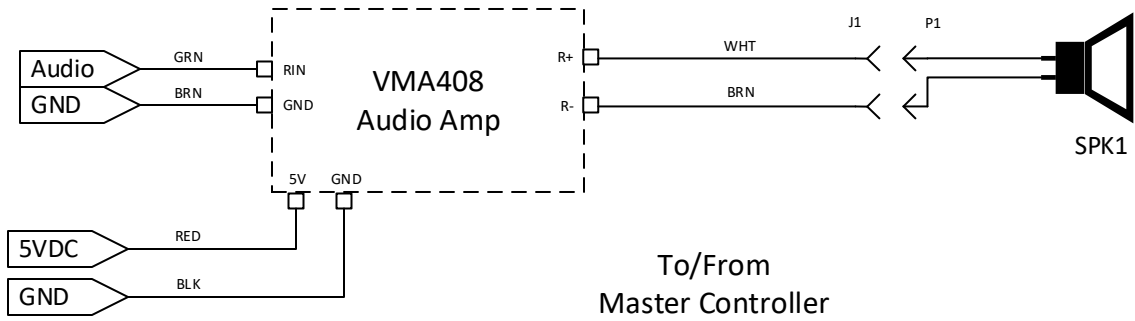

To/From Master Controller

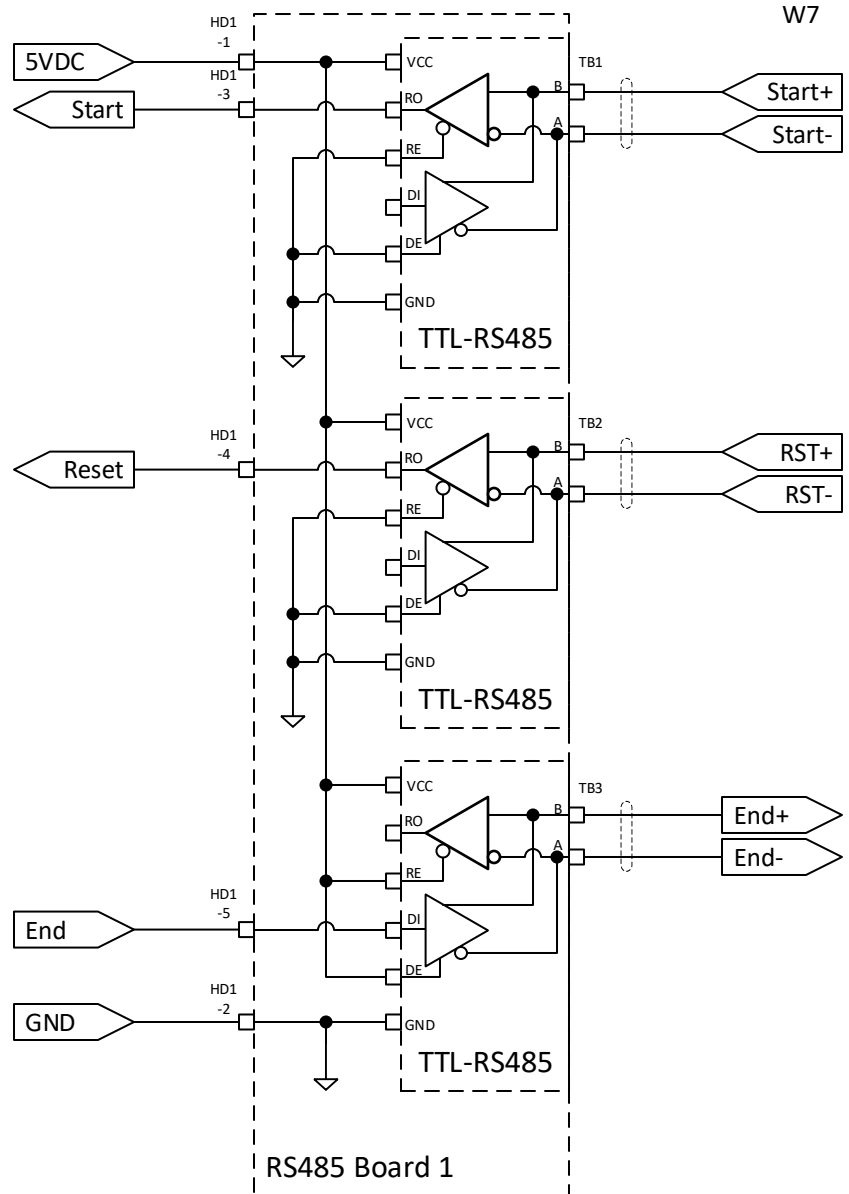

# Knight Remote Controller

Knight 1

