

**THIS IS A SIMPLIFIED DRAFT
YOUR VERSION WILL BE TO A HIGHER LEVEL OF DETAIL**

BREAK ALL SHARP EDGES

PARTS LIST			DRAWN					
ITEM	QTY	PART NUMBER	jbraithwaite	3/16/2015	MANUFACTURING ENGINEERING TECHNICIAN			
1	2	Grill Support	CHECKED		TITLE SIMPLIFIED GRILL ASSEMBLY DRAWING MATERIAL TO BE 3/8" SQUARE STOCK AND 3/8"x1-1/4" BAR			
2	6	Grill Square Rod						
3	1	Grill Handle	 THIRD ANGLE PROJECTION		SIZE	TOLERANCES	DWG NO	
4	1	Short Grill			A	.XXX - .010	Simplified Fire Pit Details	REV
5	2	Center Grill Supports			SCALE 1:4	.XX - .015 .X - .031		
						SHEET 1 OF 3		

2

1

B

B

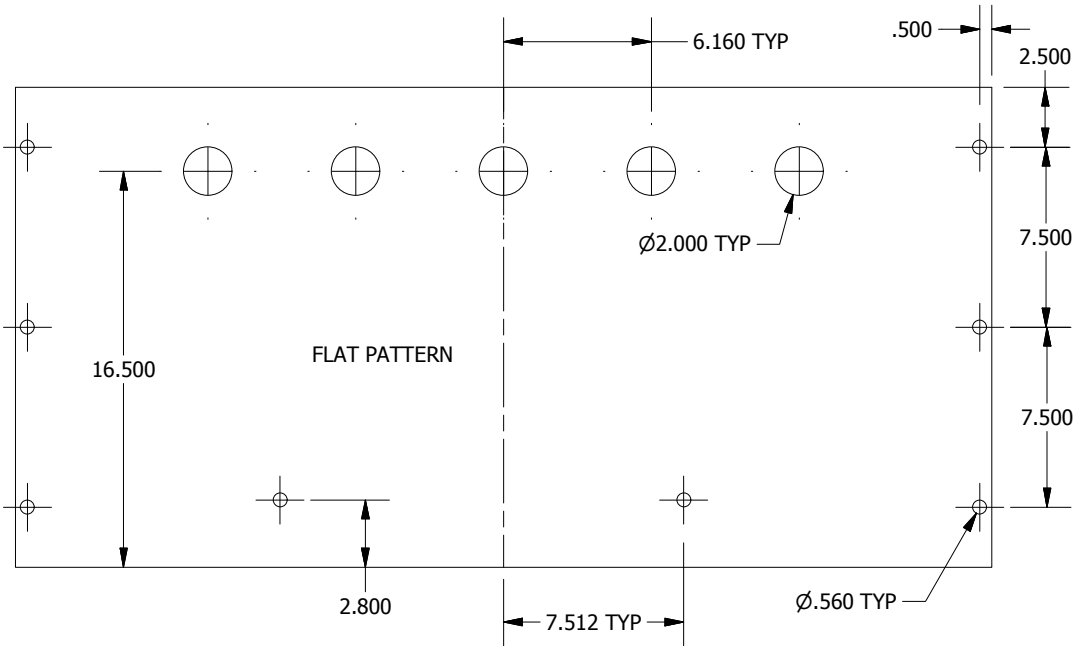
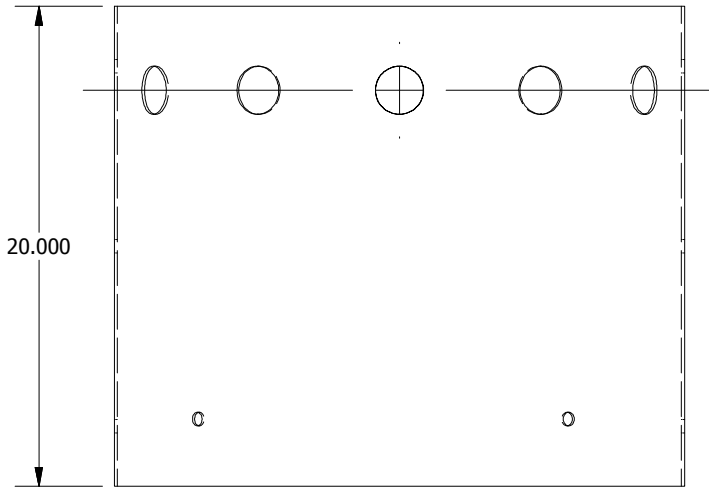
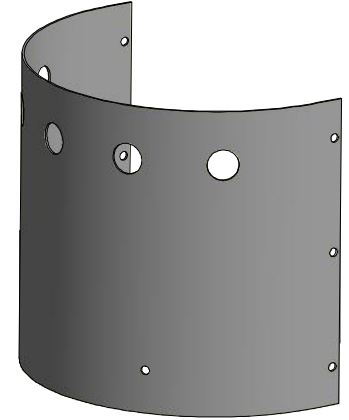
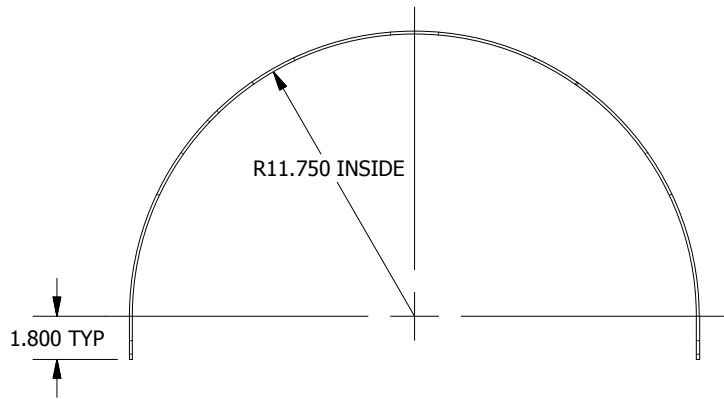

A

A

DRAWN
jbraithwaite
3/16/2015

CHECKED

MANUFACTURING ENGINEERING TECHNICIAN

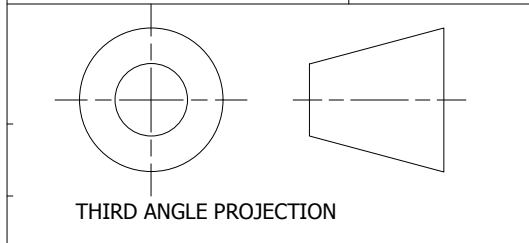

TITLE
FRONT PLATE SIMPLIFIED DETAIL
MATERIAL 0.125" MILD STEEL

SIZE A	TOLERANCES .XXX - .010 .XX - .015 .X - .031	DWG NO Simplified Fire Pit Details	REV
SCALE 1:8	SHEET 2 OF 3		

2

1



2

1

B

B

A

A

2

1

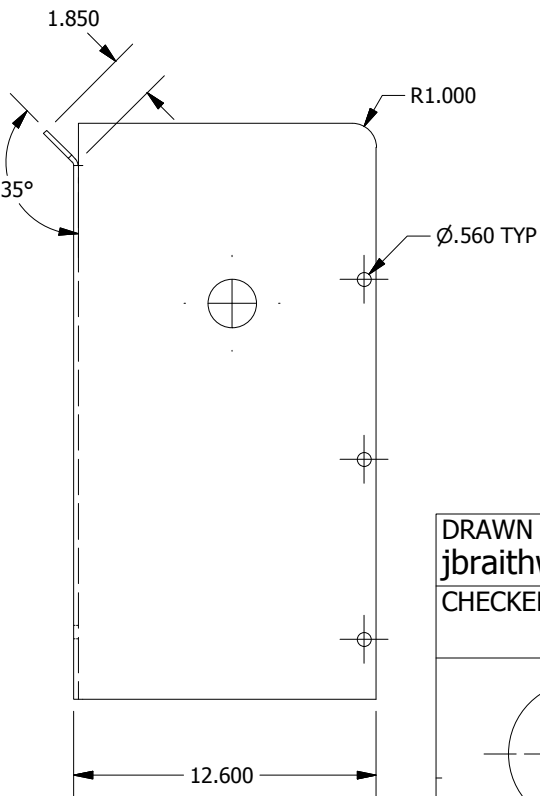
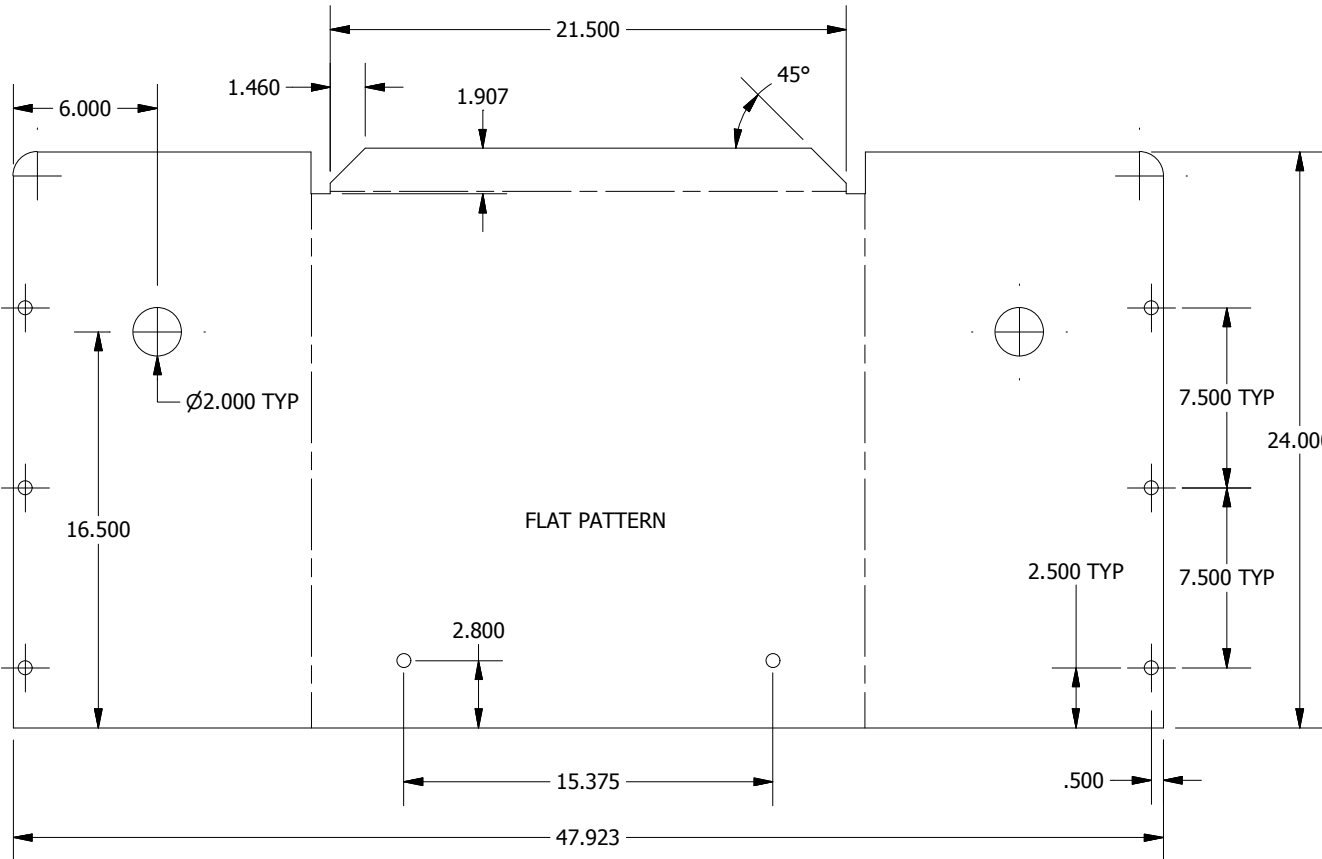
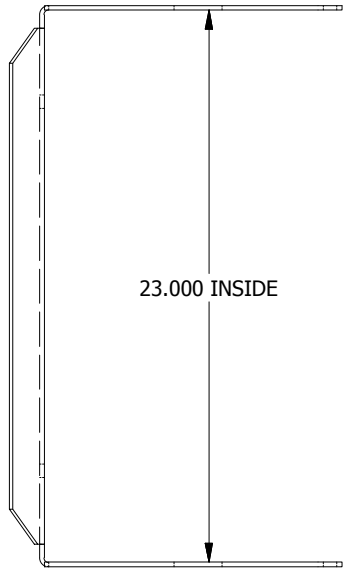

DRAWN jbraithwaite	3/16/2015
CHECKED	

MANUFACTURING ENGINEERING TECHNICIAN	
TITLE	

BACK PANEL SIMPLIFIED DRAWING
MATERIAL TO BE 0.1875" MILD STEEL

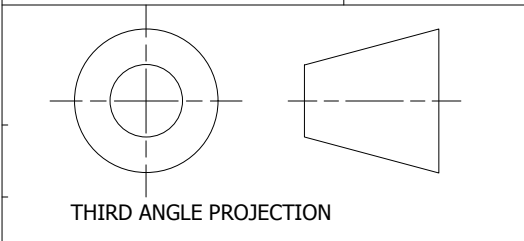

SIZE A	TOLERANCES .XXX - .010 .XX - .015 .X - .031	DWG NO Simplified Fire Pit Details	REV
SCALE 1:8	SHEET 3 OF 3		