

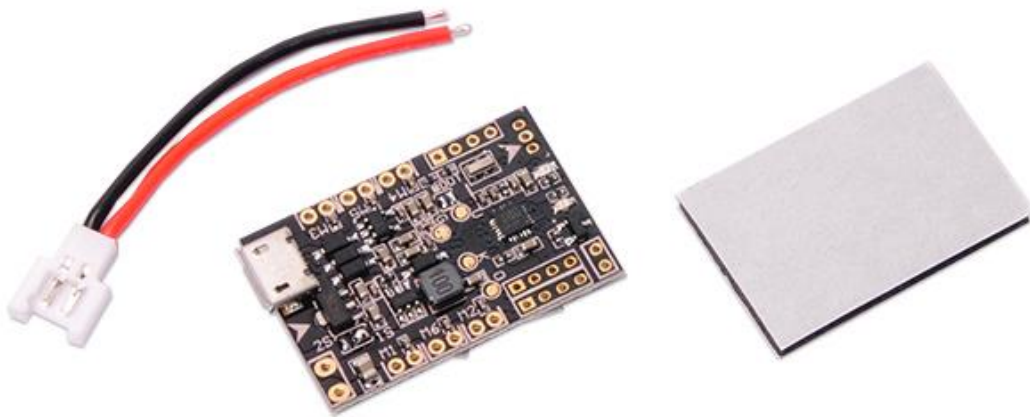

Hyperion F3 Evo Brushed Manual



Copyright Hyperion 2016

The Hyperion F3 EVO Brushed Flight Controller gives you all the features in a small size and designed for micro size quads with brushed motors.

Dedicated Open source Cleanflight software ensures that you are always updated.

Board layout

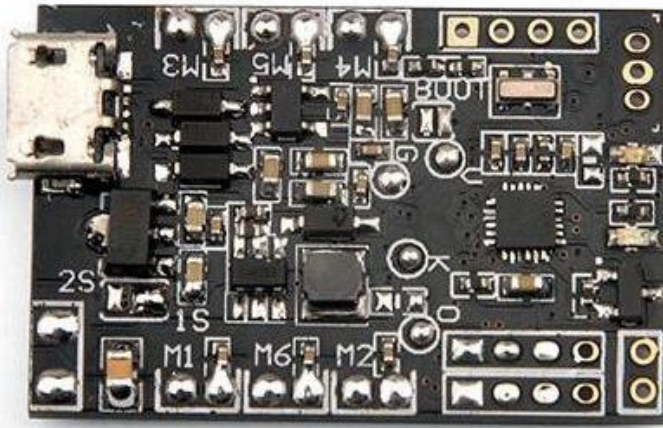

Description:

Brand Name: Hyperion

Item Name: F3 EVO Brushed Flight Controller

Dimension: 22mm*32.5mm

Thickness: 1.2mm

Weight: 3g

Features:

1. F3_EVO_Brush is in the revision on the basis of the F3 EVO SP RACING, it is a 32bits brush flight controller based on SP RACING F3 EVO firmware.
2. **The flight control support 1S (4.2V) and 2S (8.4V) power supply**, with 2S power, flying experience can be more wild.
3. Independent design of the circuit structure, comes with the pressure reduction technology, whether it is 1S or 2S power input, UART1/2 output 5V, UART3 output 3.3V
4. Using STM32F303CCT6 + MPU6500, advanced hardware platform F3 guarantee more stable flight.
5. **With a 6-ways large current NMOS transistors, operating current of up to 10A or more.** Each machine is equipped with freewheeling diodes.
6. **Support for PPM, SBUS, DSM receiver input signal.**
7. With battery voltage detection and buzzer interface.
8. **Support for 6 motors**, including 1020 coreless motor.

Connection diagram:

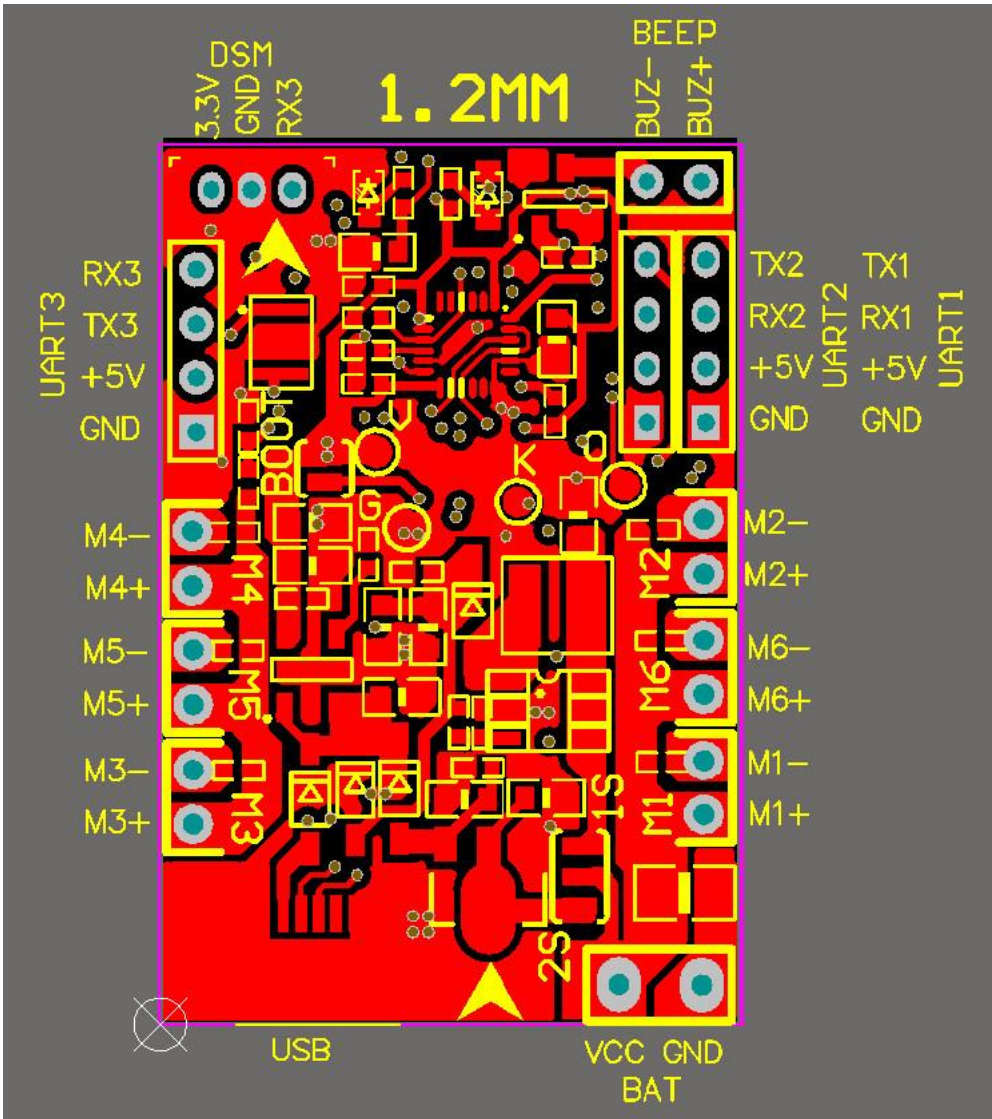

Micro USB socket: Connect to computer to flash firmware and configure the flight controller

M1/M2/M3/M4: Connect to Brush motor

VCC/GND: Connect to the battery 1s~2s input (Configure by the voltage input pad)

UART1: GND +5V RX1 TX1, could connect to GPS/OSD

UART2: GND +5V RX2 PPM/SBUS Receiver input (RX2)

UART3: GND +5V RX3 TX3 Could connect to GPS OR Telemetry module, could not use when DSM/DSM2/DSMX Receiver Used

BUZ+ -: Connect to an external buzzer

DSM/DSM2/DSMX: 3.3V GND RX3 DSM/DSM2/DSMX Receiver input

Receiver configuration:

1. DSM receiver soldered directly to the DSM/DSM2/DSMX Receive interface 3.3V, GND, RX3. Enable Serial_RX for UART3 and Set Receiver mode RX_SERIAL, Select Spektrum1024(DSM/DSM2) or Spektrum2048(DSMX) in Cleanflight configurator.

Ports DOCUMENTATION FOR 1.15.0

Note: not all combinations are valid. When the flight controller firmware detects this the serial port configuration will be reset.
Note: Do NOT disable MSP on the first serial port unless you know what you are doing. You may have to reflash and erase your configuration if you do.

Identifier	Data	Logging	Telemetry	RX	GPS
USB VCP	<input checked="" type="checkbox"/> MSP 115200 ▾	<input type="checkbox"/> Blackbox 115200 ▾	Disabled ▾ AUTO ▾	<input type="checkbox"/> Serial RX	<input type="checkbox"/> 57600 ▾
UART1	<input checked="" type="checkbox"/> MSP 115200 ▾	<input type="checkbox"/> Blackbox 115200 ▾	Disabled ▾ AUTO ▾	<input type="checkbox"/> Serial RX	<input type="checkbox"/> 57600 ▾
UART2	<input type="checkbox"/> MSP 115200 ▾	<input type="checkbox"/> Blackbox 115200 ▾	Disabled ▾ AUTO ▾	<input type="checkbox"/> Serial RX	<input type="checkbox"/> 57600 ▾
UART3	<input type="checkbox"/> MSP 115200 ▾	<input type="checkbox"/> Blackbox 115200 ▾	Disabled ▾ AUTO ▾	<input checked="" type="checkbox"/> Serial RX	<input type="checkbox"/> 57600 ▾

Receiver Mode

- RX_PPM PPM RX input
- RX_SERIAL Serial-based receiver (SPEKSAT, SBUS, SUMD)
- RX_PARALLEL_PWM PWM RX input (one wire per channel)
- RX_MSP MSP RX input (control via MSP port)

Serial Receiver Provider

Note: Remember to configure a Serial Port (via Ports tab) and choose a Serial Receiver Provider when using RX_SERIAL feature.

- SPEKTRUM1024**
- SPEKTRUM2048
- SBUS
- SUMD
- SUMH
- XBUS_MODE_B
- XBUS_MODE_B_RJ01
- IBUS

2. SBUS receiver welded to the UART2 GND, + 5V, RX2. Then Enable Serial_RX and Set Receiver mode RX_SERIAL, Select Sbus signal in Cleanflight configurator.

Ports DOCUMENTATION FOR 1.13.0

Note: not all combinations are valid. When the flight controller firmware detects this the serial port configuration will be reset.
Note: Do **NOT** disable MSP on the first serial port unless you know what you are doing. You may have to reflash and erase your configuration if you do.

Identifier	Data	Logging	Telemetry	RX	GPS
------------	------	---------	-----------	----	-----

Receiver Mode

- RX_PPM PPM RX input
- RX_SERIAL Serial-based receiver (SPEKSAT, SBUS, SUMD)
- RX_PARALLEL_PWM PWM RX input (one wire per channel)
- RX_MSP MSP RX input (control via MSP port)

Serial Receiver Provider

Note: Remember to configure a Serial Port (via Ports tab) and choose a Serial Receiver Provider when using RX_SERIAL feature.

- SPEKTRUM1024
- SPEKTRUM2048
- SBUS**
- SUMD
- SUMH
- XBUS_MODE_B
- XBUS_MODE_B_RJ01
- IBUS

3. PPM receiver welded to the UART2 GND, + 5V, RX2. Then set Receiver mode to RX_PPM in Cleanflight configurator.

Identifier	Data	Logging	Telemetry	RX	GPS
USB VCP	<input checked="" type="checkbox"/> MSP 115200	<input type="checkbox"/> Blackbox 115200	Disabled AUTO	<input type="checkbox"/> Serial RX	<input type="checkbox"/> 57600
UART1	<input checked="" type="checkbox"/> MSP 115200	<input type="checkbox"/> Blackbox 115200	Disabled AUTO	<input type="checkbox"/> Serial RX	<input type="checkbox"/> 57600
UART2	<input type="checkbox"/> MSP 115200	<input type="checkbox"/> Blackbox 115200	Disabled AUTO	<input type="checkbox"/> Serial RX	<input type="checkbox"/> 57600
UART3	<input type="checkbox"/> MSP 115200	<input type="checkbox"/> Blackbox 115200	Disabled AUTO	<input type="checkbox"/> Serial RX	<input type="checkbox"/> 57600

Receiver Mode

- RX_PPM PPM RX input
- RX_SERIAL Serial-based receiver (SPEKSAT, SBUS, SUMD)
- RX_PARALLEL_PWM PWM RX input (one wire per channel)
- RX_MSP MSP RX input (control via MSP port)

Serial Receiver Provider

Note: Remember to configure a Serial Port (via Ports tab) and choose a Serial Receiver Provider when using RX_SERIAL feature.

- SPEKTRUM1024
- SPEKTRUM2048
- SBUS
- SUMD
- SUMH
- XBUS_MODE_B
- XBUS_MODE_B_RJ01
- IBUS

Notice:

Before applying power, pay attention to the battery voltage selection. The default setting is 1S (4.2V); if you use 2s lipo, please first need to disconnect pin2 and pin 3 and then solder pin 1 and pin2. Prohibit the same three pads shorted together.

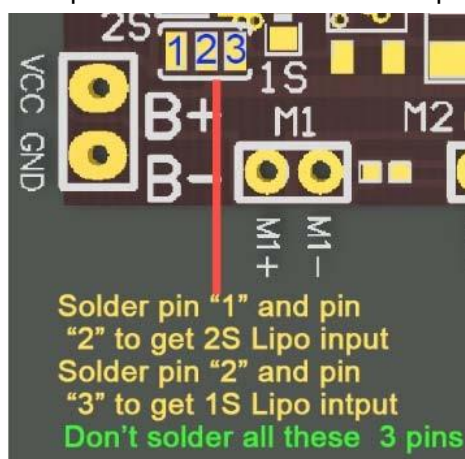

FIRMWARE FLASHING for F3 EVO Brush

The following tutorial covers flashing Cleanflight Firmware onto the F3 EVO Brush Flight Controller. Betaflight is the same steps like Cleanflight.

Installing the ST drivers:

(For Windows Only)

[Download](#) and install the [DfuSe demo package](#).

Open an explorer window and browse to (assuming you've installed to the default path) C:\Program Files (x86)\STMicroelectronics\Software\DfuSe v3.0.5\Bin\Driver

Browse two folders deeper to the folder relative to your Operating System version, and x86-32bit or x64-64bit variant.

Click the dpinst_x##.exe to install the driver.



Installing Cleanflight Configurator:

(For Windows Only)

You must use Cleanflight Configurator v 1.0.0 or newer.

The following assumes you also have the [Chrome Browser](#) installed.

[Get](#) the latest Cleanflight Configurator (+ Add to Chrome)

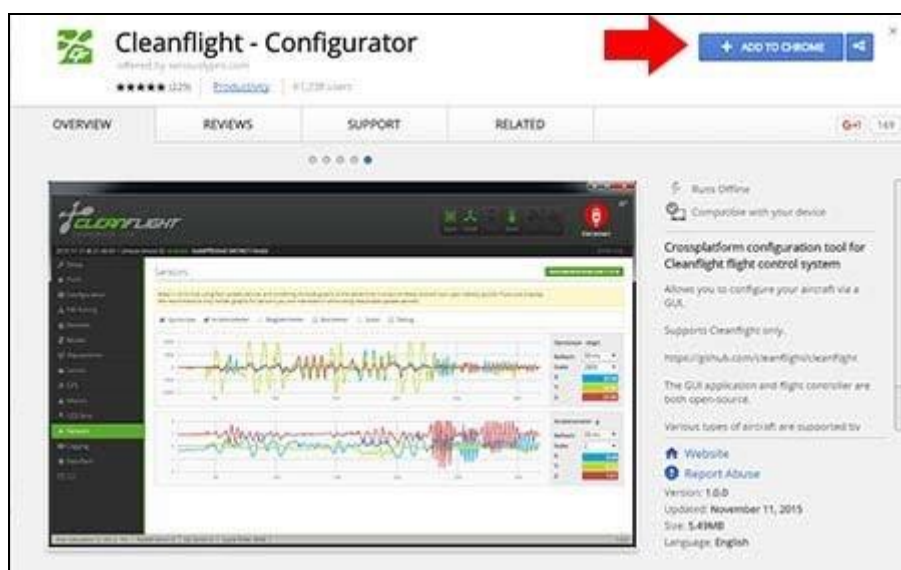

Replacing the ST Driver with WinUSB driver:

(For Windows Only)

1. Plug your F3 EVO_Brush board onto your computer. Open cleanflight configurator , you should see the serial com port

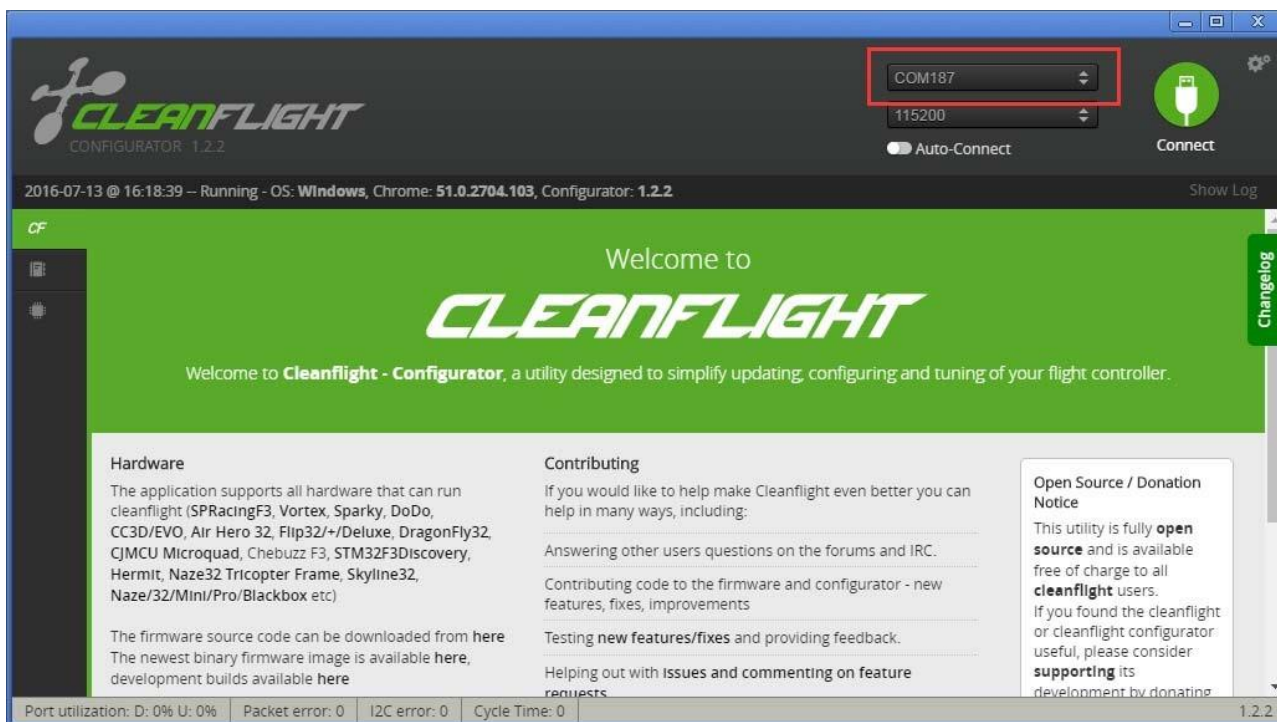

2. Click “Firmware Flash” menu, select the latest firmware for F3 EVO_Brush and load firmware [online] or load firmware [Local]

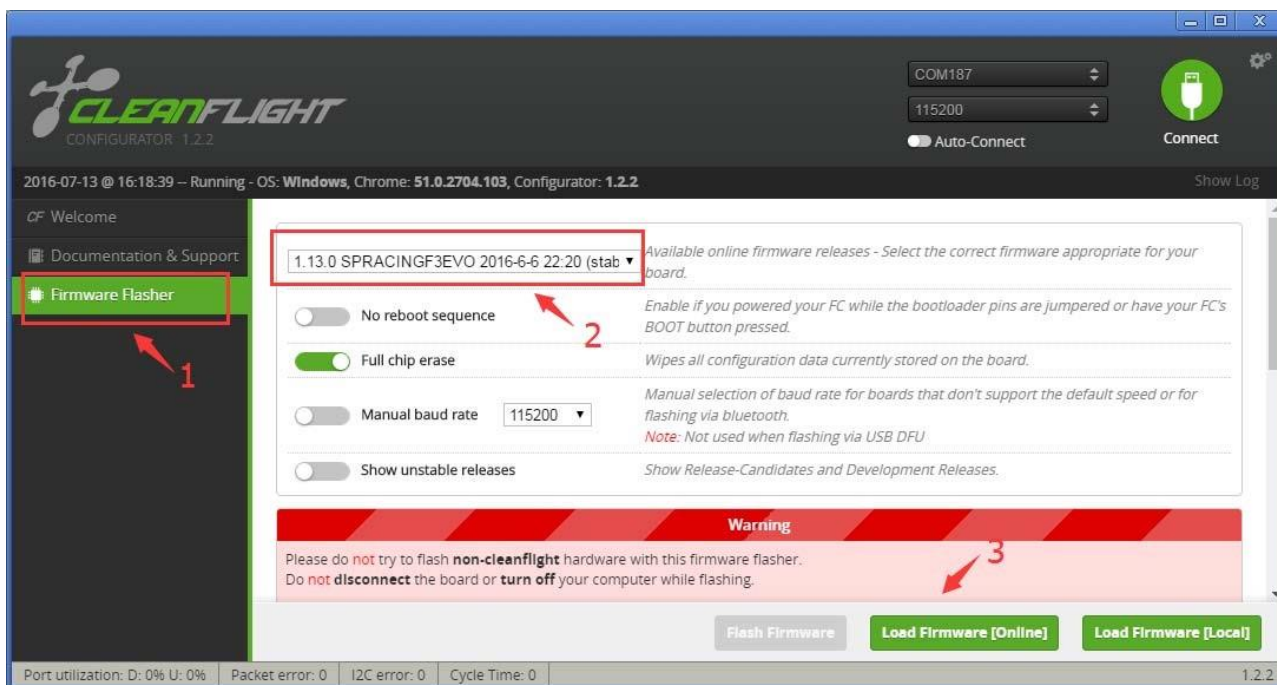

3. Click “Flash Firmware” and wait the ST DFU DRIVER Automatic installation. It’s successfully installed when you see the DFU port on the Up right corner.

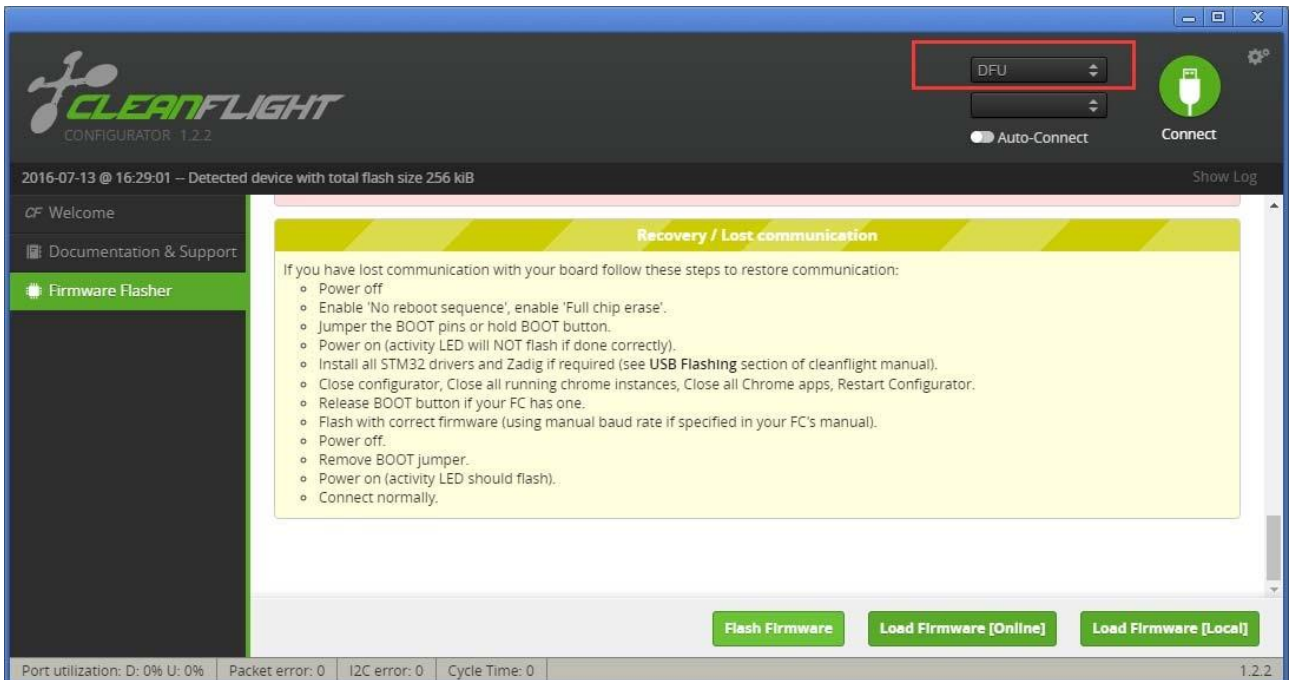

4. [Download](#) and launch Zadig
5. From Zadig, a.) Select Options, b.) Tick List All Devices

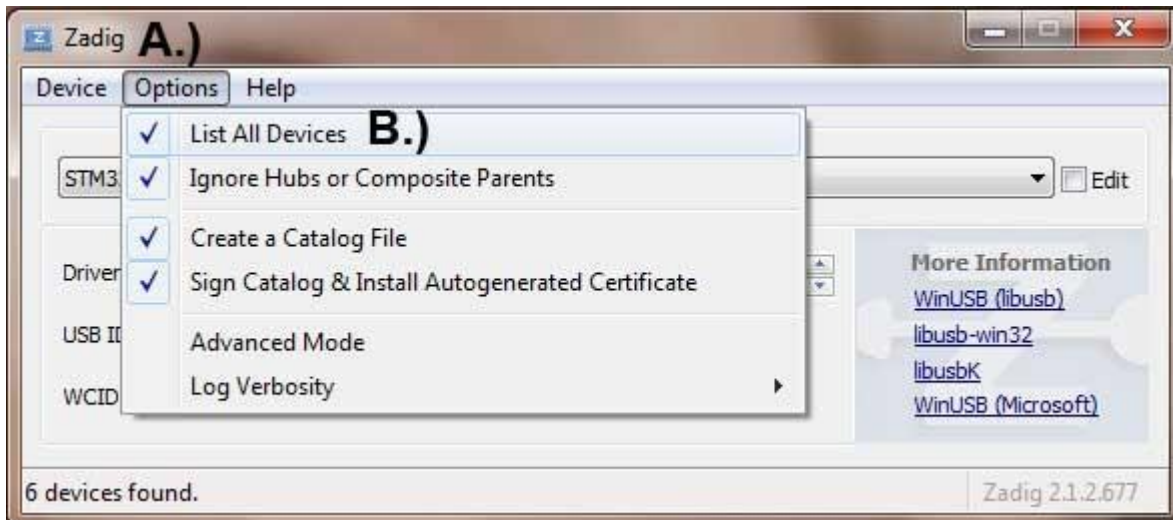

6. a.) Select STM32 Bootloader from the dropdown, b.) Choose WinUSB as the replacement, c.) Click Replace Driver. Sometimes the Replace progress will be slow or no response, you can close it and do it again, you will find the dropdown is no STTUB30 but WinUSB, just click replace driver from WinUSB to WinUSB .

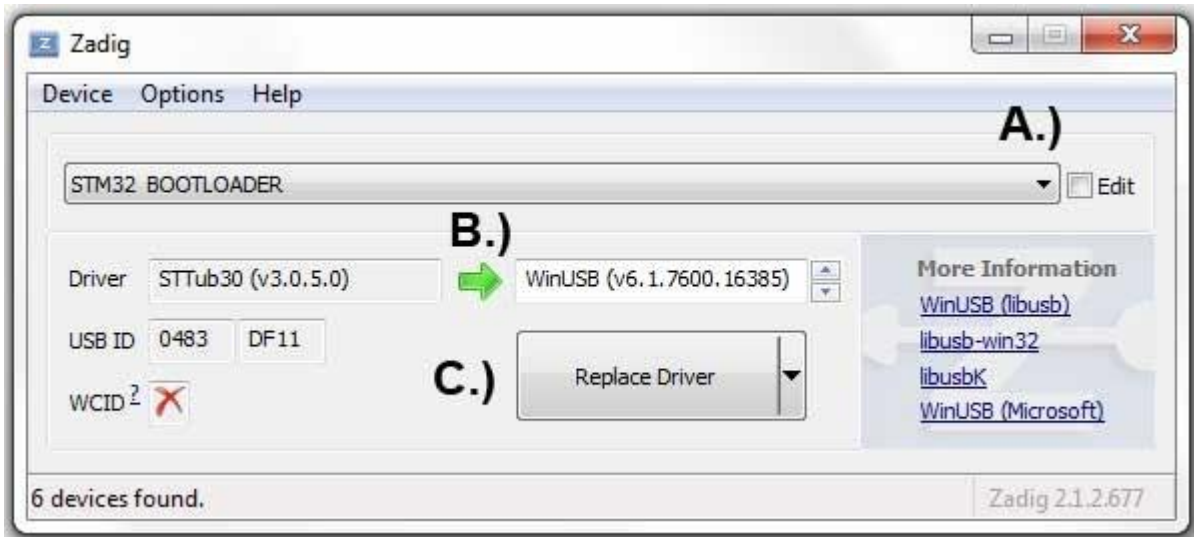

* Credits for the Zadig option – Cleanflight Docs

Flash Firmware

Go back to Cleanflight configurator and Click Flash Firmware

Flash Firmware again after the Driver replace completed, and you will see the firmware flashed successfully!

Warnings!

This F3 EVO_Brush flight controller is only for use with BRUSH MOTOR, and Not compatible for BRUSHLESS MOTOR