

# Elevation LED Indicator Piece 1 - optional

## SIDE VIEW

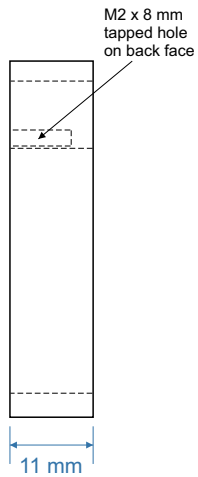

## FRONT VIEW

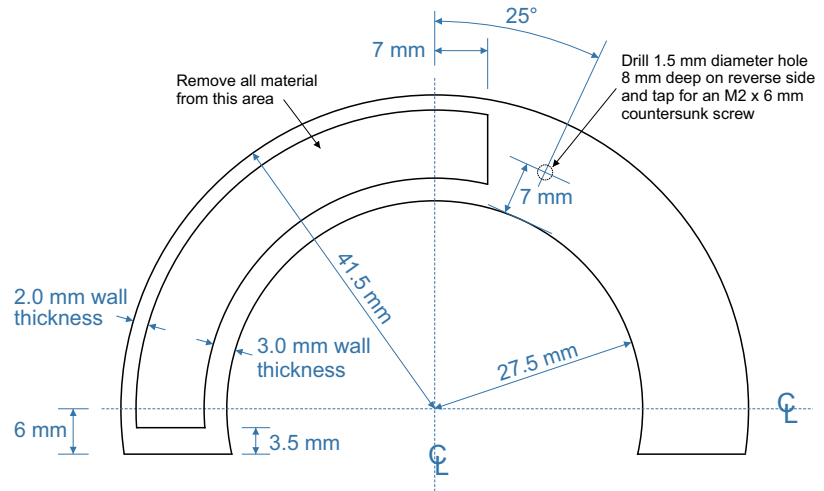

## BOTTOM VIEW

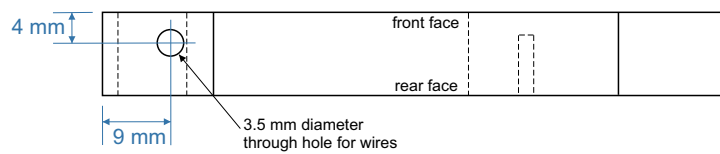

Material: PVC rod painted black

Photos showing unpainted finished item



# Elevation LED Indicator Piece 2 - optional

SIDE VIEW

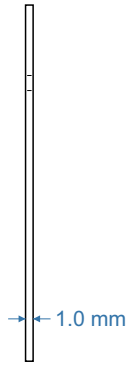

FRONT VIEW

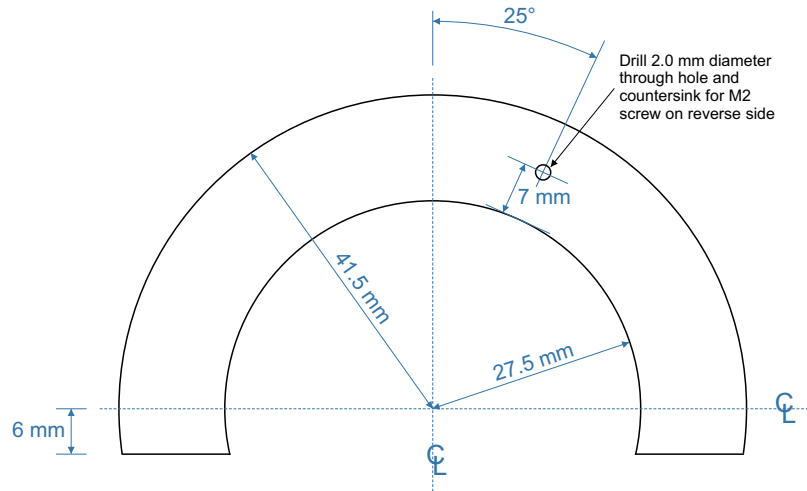

BOTTOM VIEW

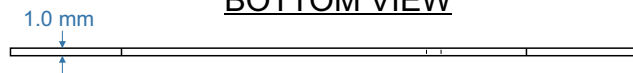

Material: PVC rod painted black

Assembly: Screw this piece into rear of Piece 1 using an M2 x 6 mm long countersunk screw

Photos showing unpainted finished item



# Elevation LED Indicator Piece 3 - optional

SIDE VIEW

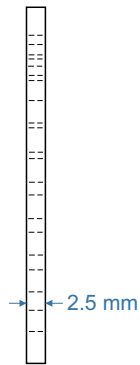

FRONT VIEW

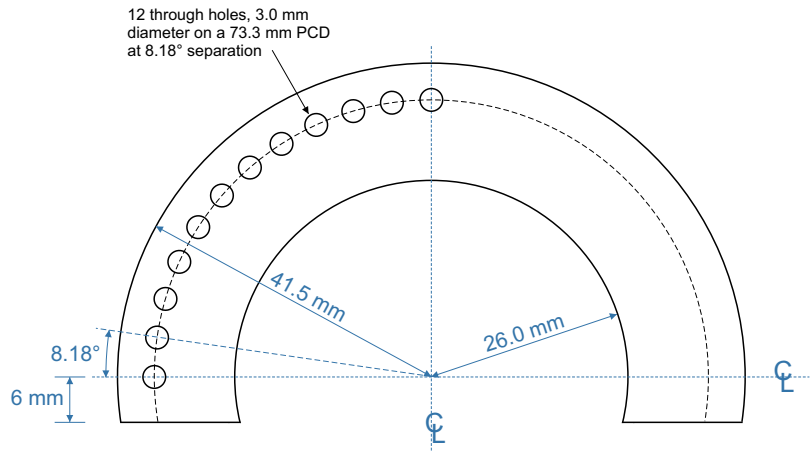

BOTTOM VIEW

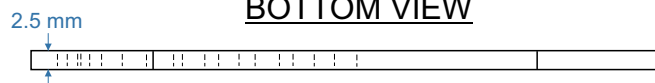

Material: PVC rod painted black

Assembly: Glue this piece onto front of Piece 1 aligning the 2 outer edges together

Photos showing unpainted finished item

