

8 7 6 5 4 3 2 1

REVISIONS					
REV.	ECR	DESCRIPTION	DRAFTER	DATE	APPROVED

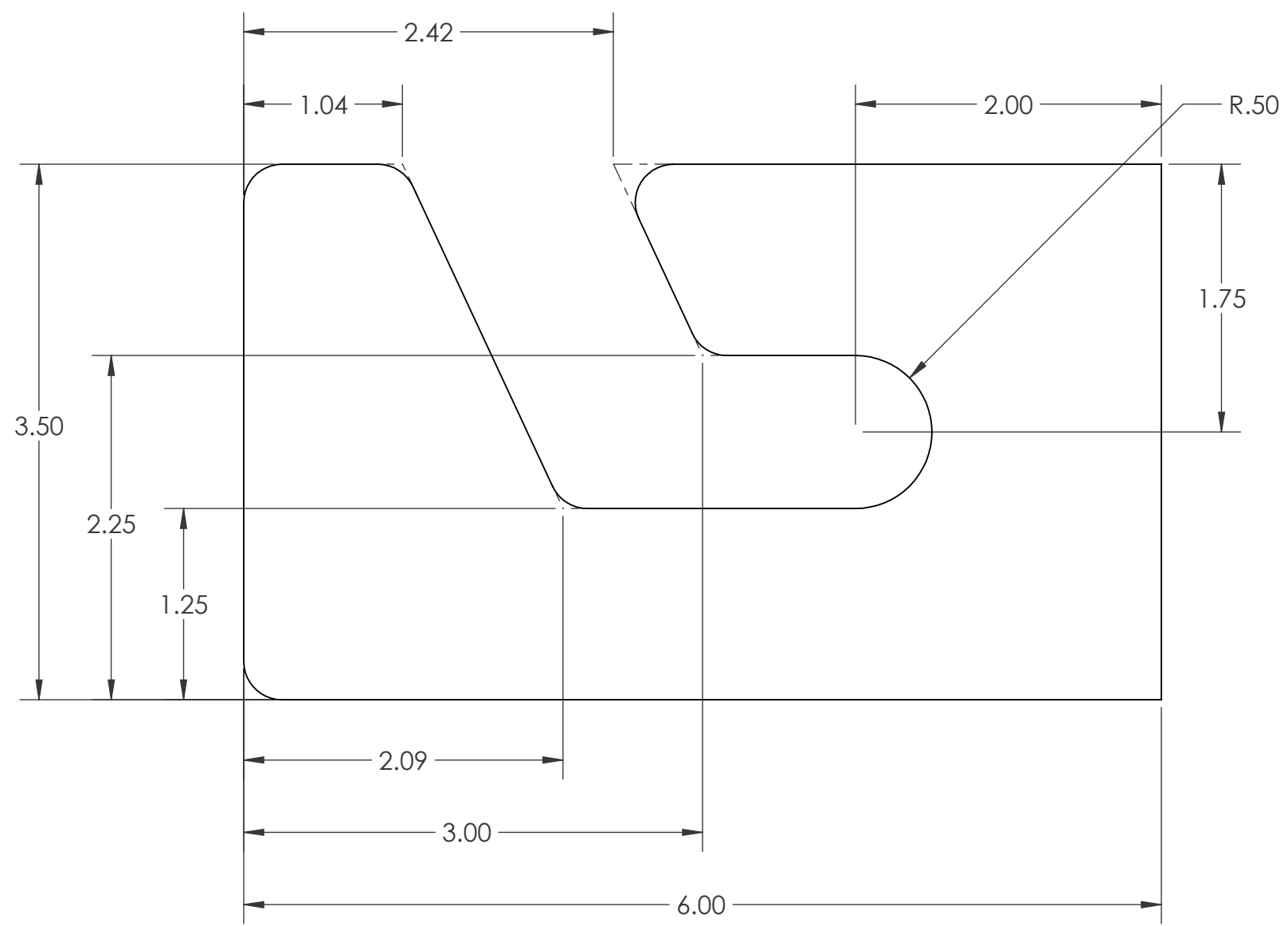

UNLESS OTHERWISE SPECIFIED:
 DIMENSIONS ARE IN INCHES
 MACHINING TOLERANCES:
 ANGULAR: MACH ±30'
 BEND ±30'
 ONE PLACE DECIMAL ±0.1
 TWO PLACE DECIMAL ±0.015
 THREE PLACE DECIMAL ±0.005
 BREAK CORNERS .015
 FINISH $\sqrt{125}$ RMS

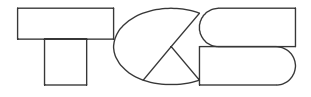

TITLE:
**DRAWING TABLE, PAPER
 ROLL SUPPORT**

MATERIAL	Pine		SIZE	DWG. NUMBER	REV
	= CRITICAL () = REFERENCE		B	DT-007	
DRAFTER	ATJ	DATE	26-MAY-19	SCALE: 1:1	WT: 0.15 lbs
					SHEET 1 OF 1

8 7 6 5 4 3 2 1