

# CONSTRUCTION MANUAL

## Sand Art Display-2

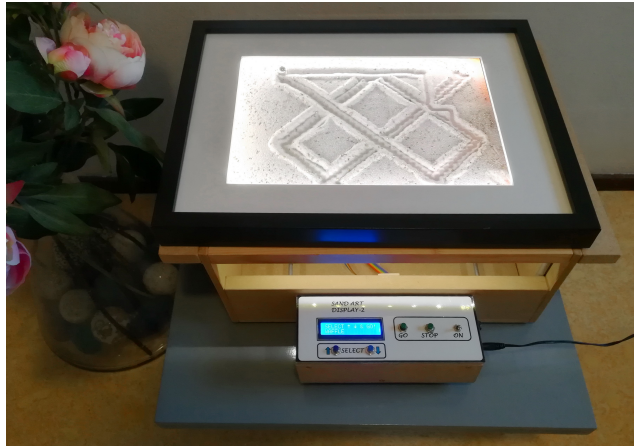

Imagine a Japanese Zen garden built into a glass-covered picture frame. Below the frame are electronics and robotics, creating geometric patterns and images in the sand. The effect is enchanting and magical, it is really Zen-like to see ever-changing patterns and images slowly appear in the sand. A Sand Art Display is a modern version of this traditional Zen sand garden. It is a drawing machine that creates mandala-like patterns in the sand. The operation of this display is as follows: under the glass top is a thin layer of sand, under the sand a twin-engine robot moves a strong magnet to steer a steel ball through the sand. The robot is controlled by an Arduino mini computer playing a pattern program, similar to the way a music player plays MP3 songs. The table calibrates itself when plugged in and after this calibration a number of pre-programmed patterns can be selected using the push buttons.

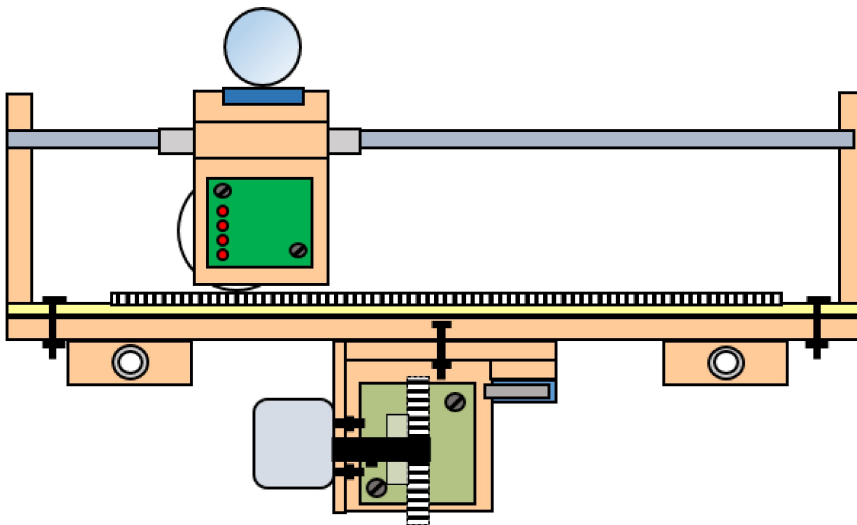

## CONTENT

3	REQUIREMENTS (TOOLS AND PARTS)
5	THE HOUSING
7	THE PICTURE FRAME
8	THE SAND HOLDER
9	THE X-CARRIAGE
10	THE MOTOR DRIVE FOR THE X-CARRIAGE
12	THE Y-CARRIAGE
13	THE MOTOR DRIVE FOR THE Y-CARRIAGE
15	THE CONTROL PANEL
17	THE WIRING
20	THE SOFTWARE

Construction manual	February 2022	version 1.0
Author	Alex Pikkert	
Dimensions	All dimensions in mm.	



## REQUIREMENTS (TOOLS AND PARTS)

You will need the following skills:

- Woodworking, using a soldering iron and a multimeter.
- Connecting and programming an Arduino microcontroller.

Can't you do this yourself? Then look at FabLab's, [www.instructables.com](http://www.instructables.com) or technical hobby clubs in your area. The Arduino community also has an extensive website where you can find everything about the operation, connection and programming. See [www.arduino.cc](http://www.arduino.cc). The software is free under the Creative Commons licenses.

You will need these tools:

- Screwdrivers
- Pointed pliers
- Jigsaw
- Cordless drill
- Pillar drill machine
- Round file (5 mm.)
- Soldering iron with a fine tip
- Solder (preferably lead-free)
- Cutting pliers
- Utility knife
- Hacksaw
- Wood drills
- Sandpaper
- Wood glue
- Pattex universal adhesive
- Double-sided tape
- PC

You will need these parts:

- MDF board in thicknesses of 3,6,9,12 and 18 mm. Dimensions: see description.
- 1 m. 18x18 mm. pinewood slat.
- 2 m. 9x9 mm. pinewood slat.
- 1 m. 18x4 mm. pinewood slat.
- 1 picture frame IKEA Ribba 30x40 cm. with a white mat board.
- 1 glass plate 30x40 cm. to replace the plastic plate of the Ribba.
- fine aquarium sand.
- 2x1m. round steel rod 5 mm.
- 4 metal pins 2 mm. for fixing the sand holder.
- 1 m. aluminum tube, inner diameter 5.5-6 mm, outer diameter 8 mm.
- 2 Reely polyacetal cogwheels, module type: 0.5, drill diameter 6 mm, number of teeth: 80. Conrad part number 1515290.
- 2 pieces Reely polyacetal toothed rack 250 mm. long, module type: 0.5, Conrad item number: 1515294.
- 2 insulated alligator clips for mounting the cogwheels.
- 2x0.5 m. flexible ribbon cable 20 wire AWG28.
- mounting wire 0.2 sqmm litze in various colors

- 1 m. heat shrink tubing 1mm.
- 5 cm. heat shrink tubing 4 mm.
- 2 5V. stepper motors type 28BYJ-48 with driver board ULN2003.
- 2 LED strings warm white 1 m. (Action).
- 1 Arduino UNO R3 (original or a clone).
- 1 female built-in power plug for 5.5x2.1 mm. round plug.
- 1 power supply 9 Volt DC 1 amp. with 5.5x2.1 mm. round plug.
- 2 resistors 2.2 kOhm 1/4 Watt.
- 4 resistors 10 kOhm 1/4 Watt.
- 1 resistor 100 Ohm 1 Watt.
- 1 capacitor 1000 uF 16V.
- 1 voltage stabilizer 7805.
- 1 diode 1N4007.
- 1 heat sink TO220 for the 7805.
- 1 toggle switch.
- 4 micro switches 10T85
- 4 mini push buttons color white, yellow and blue.
- 1 built-in fuse holder with a 1 amp. glass fuse 5x20 mm.
- 1 row of connection pins for the Arduino UNO.
- 1 PCB 5x7 cm. with 24x18 holes at 0.1 inch.
- M3 bolts and nuts.
- Chipboard screws.
- 4 nylon spacers 1 mm. thick.
- 1 disc magnet 20 mm. diameter, height 5 mm.
- 1 steel ball with a diameter of 12.7 mm.
- 1 mm. thick foam rubber approx. 30x40 cm.
- 1 metal ring 30 mm. with 8.5 mm. hole.
- 10 cm. bare copper wire 2.5 sq mm.
- Gosssy photo paper.
- Clear self-adhesive plastic foil.

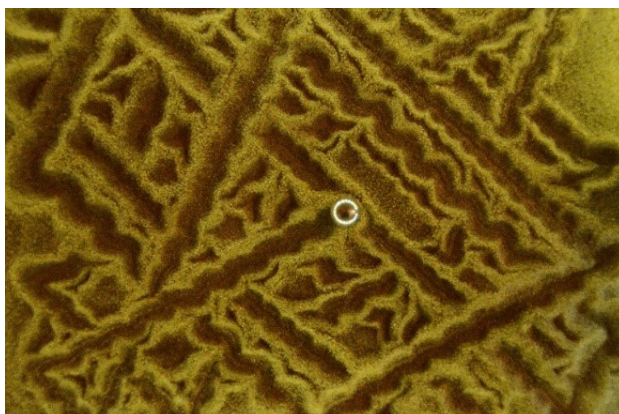

## THE HOUSING

The following components are required:

MDF:

A base plate 360x340 mm. thickness 9 mm.

B, C front/rear each 360x80 mm. thickness 18 mm.

D, E left and right side each 340x170 mm. thickness 9 mm.

H, I top left and right 340x40 mm. each. thickness 18 mm.

J, K top front and rear each 360x15 mm. thickness 6 mm.

Pinewood slat:

F, G top front and rear each 360 mm. long and 18x18 mm.

Other parts:

L, M two round steel rods, diameter 5 mm. length 332 mm.

N aluminum tube, diameter 8 mm, length 90 mm.

LED strip with a length of 27 cm. with 30 cm. flexible wiring.

First carefully drill the 5 mm. holes as shown on the drawing for guiding the Y-carriage in parts B and C. Drill the holes in the front part with a depth of 10 mm. Drill the holes in the other part fully through the MDF. In this way, the Y-carriage can be easily removed from the housing by sliding the steel rods out tot the back. Glue and screw parts B and C on the long side of the base plate A. Make sure they are perpendicular.

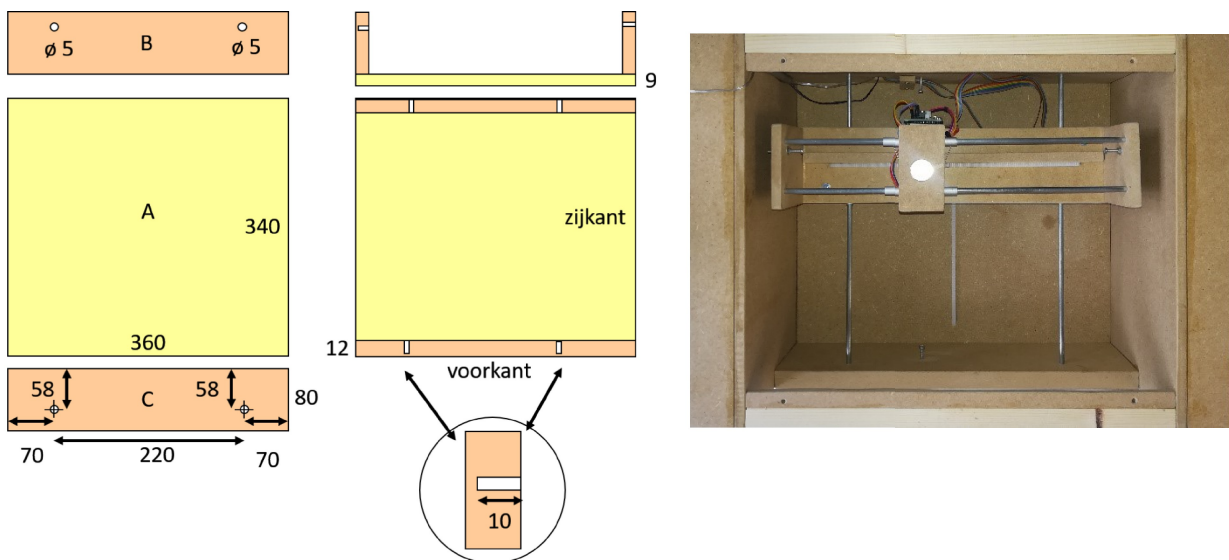

Then glue and screw the sides D and E to the base plate and the upright front and back.

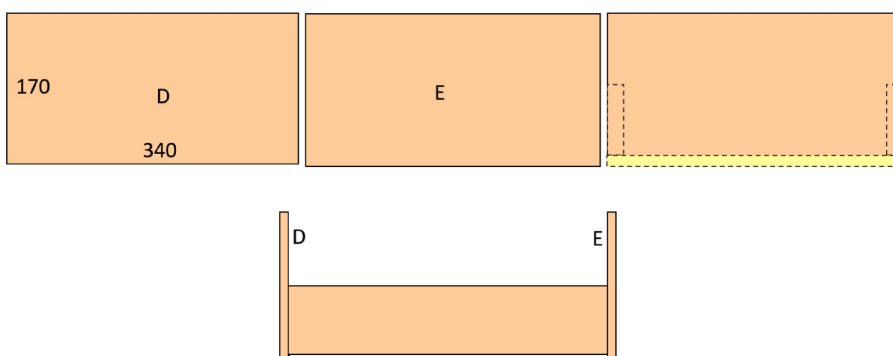

Glue and screw both pinewood slats F and G at the top between the side plates at the front and the back.

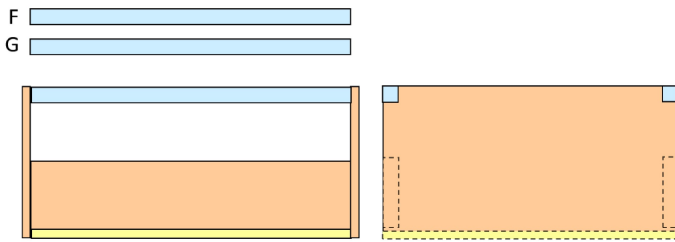

Then glue both top sides H and I on the left and right outside to the upright sides D and E.

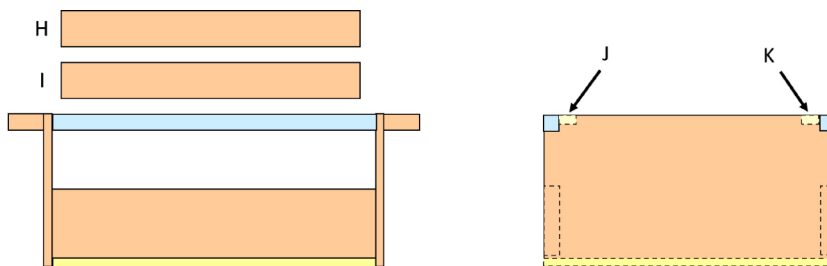

Finally, glue the MDF strips J and K on the inside at the top to the pinewood slats according to the drawing.

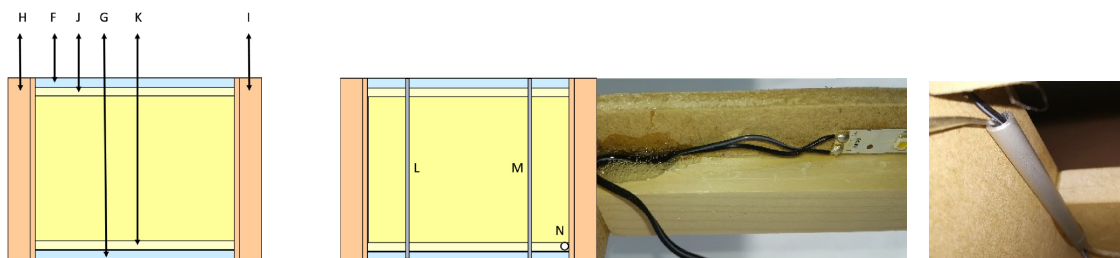

Cut two round steel rods L and M of 5 mm. diameter to a length of  $340-8 = 332$  mm. and place them in the holes of the front and back as shown on the drawing. Glue to the bottom of part K the 27 cm. LED strip and secure the wiring with glue. Glue the aluminum tube N in the right inner corner for the wiring of the LED strip under part K and the LED strip that will be mounted inside the picture frame.

## THE PICTURE FRAME



The display is covered at the top with a black RIBBA picture frame from IKEA, with a white mat board. This frame has a plastic cover, to get a more beautiful appearance, it has been replaced by a real glass plate of 30x40 cm. First remove the back plate and cut a rectangular hole in it, the edges of which fall just behind the mat board so that this back plate is not visible. Saw the pinewood slat of 18x4 mm. lengthwise in the middle to get two slats of 9x4 mm. Glue these slats upright all around on the back plate at a distance of 20 mm. from the outer edge.



Glue the LED strip on the inside of the 9x4 mm. slat, solder 50 cm. flexible wiring to the strip, glue this on the wood with a shrink sleeve protection to prevent damage. The led strip is just a few LEDs too short, so solder a part of a second strip to it. Of the remaining LEDs, a few are glued in the housing at the top under the part K so that the mechanism of the display is also illuminated. The LED strip can easily be cut on the oval copper surfaces and soldered together.

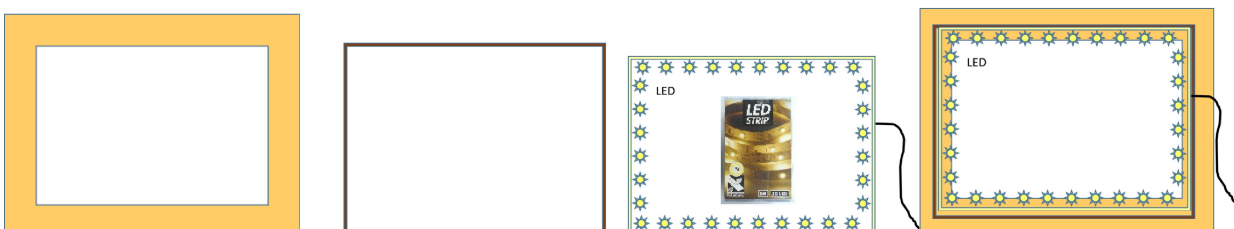

## THE SAND HOLDER

The following components are required:

A: MDF base plate 383x300 mm. 3 mm. thickness.

B: 2 m. pinewood slat, 9x9 mm.

C: 4 metal pins 2 mm.

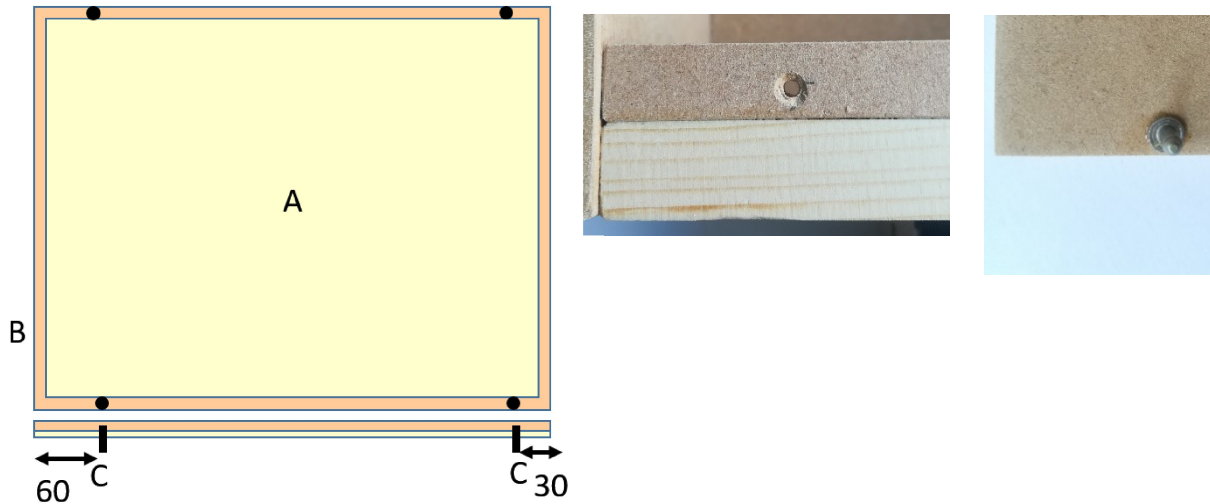

The sand holder consists of a base plate (A) with a slat (B) of 9x9 mm. glued to the edge. The corners of this slat are cut at 45 degrees to ensure a good fit. At the bottom of the long sides are 2 mm. metal pins mounted to fix the holder to the housing. For this, old pop rivets are used, any other material will also do. Drill 4 holes of 3 mm. in the slats J and K of the housing for these pins, to lock the sand holder on the top of the housing with a gap of a few mm. on the right side for the wiring of the LED strip. Place a 1 mm. layer of foam rubber in the sand holder. With this foam rubber the steel ball will be pulled smoothly through the sand by the magnet.

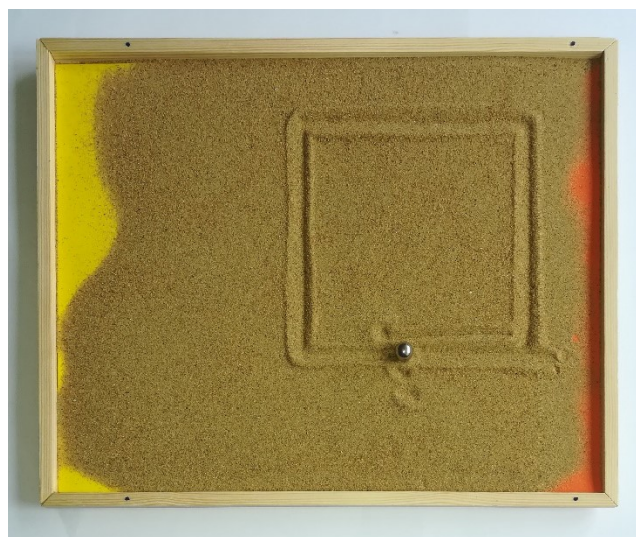



## THE X-CARRIAGE

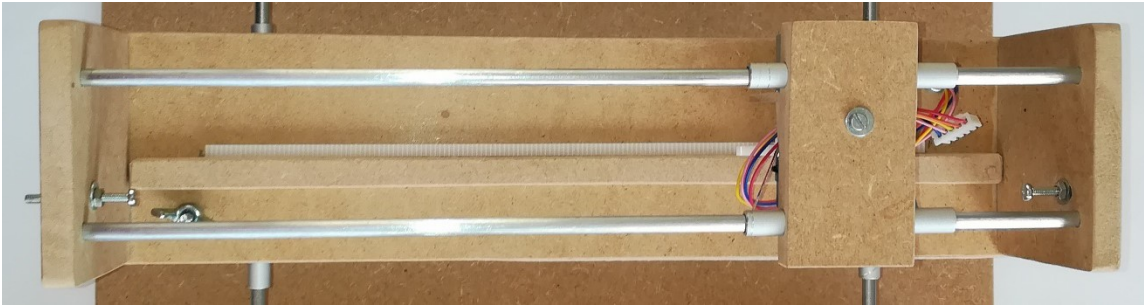

The following components are required:

MDF:

A base plate 320x75 mm. 3 mm. thickness.

B, C side each 70x75 mm. 9 mm. thickness.

Other parts:

D, E two round steel rods, diameter 5 mm. length 316 mm.

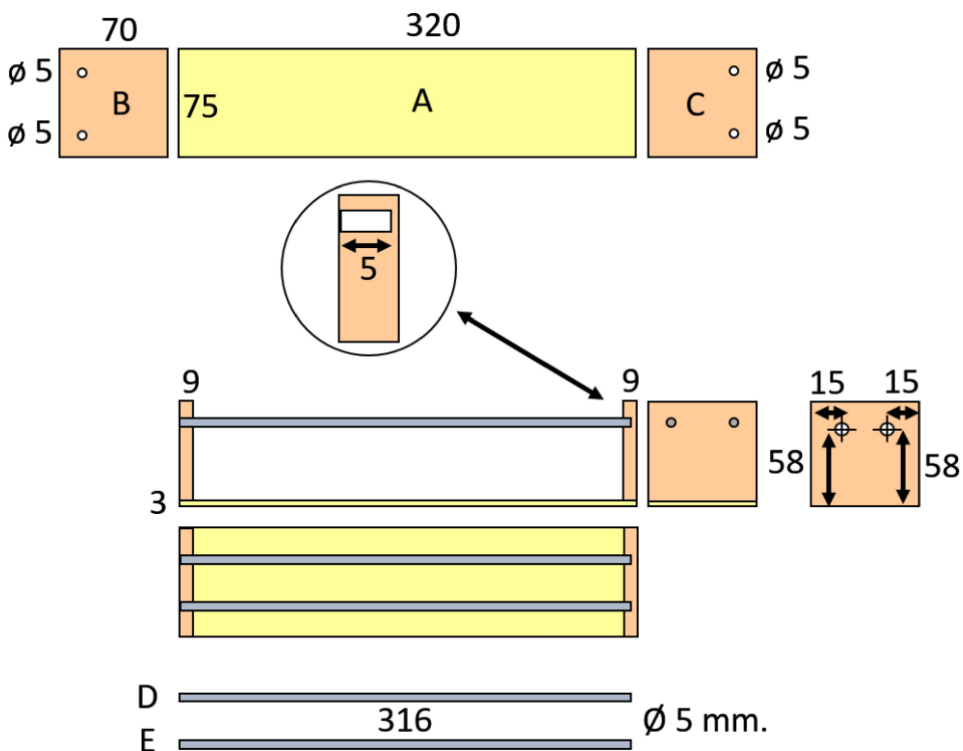

First carefully drill the 5 mm. holes as shown on the drawing for guiding the Y-carriage in parts B and C. Drill the holes in one part with a depth of 5 mm. Drill the holes in the other part fully through the MDF. In this way, the X-carriage can be easily removed by sliding the steel rods out. The center-to-center distance between the holes is 45 mm. Glue parts B and C on the small sides of base plate A. Make sure they are perpendicular. Handle this construction with care, the base plate with a thickness of 3 mm. can easily be cracked.

## THE MOTOR DRIVE FOR THE X-CARRIAGE

The following components are required:

MDF:

A driver plate 45x40 mm. 6 mm. thickness.

B top plate 40x75 mm. 12 mm. thickness.

C motor mount 40x15 mm. 6 mm. thickness.

D motor plate 45x40 mm. 3 mm. thickness.

E magnetic plate 40x75 mm. 12 mm. thickness.

F raising plate 40x75 mm. 3 mm. thickness.

Other parts:

2 aluminum tubes 8 mm. length 65 mm.

1 insulated alligator clip to mount the cogwheel.

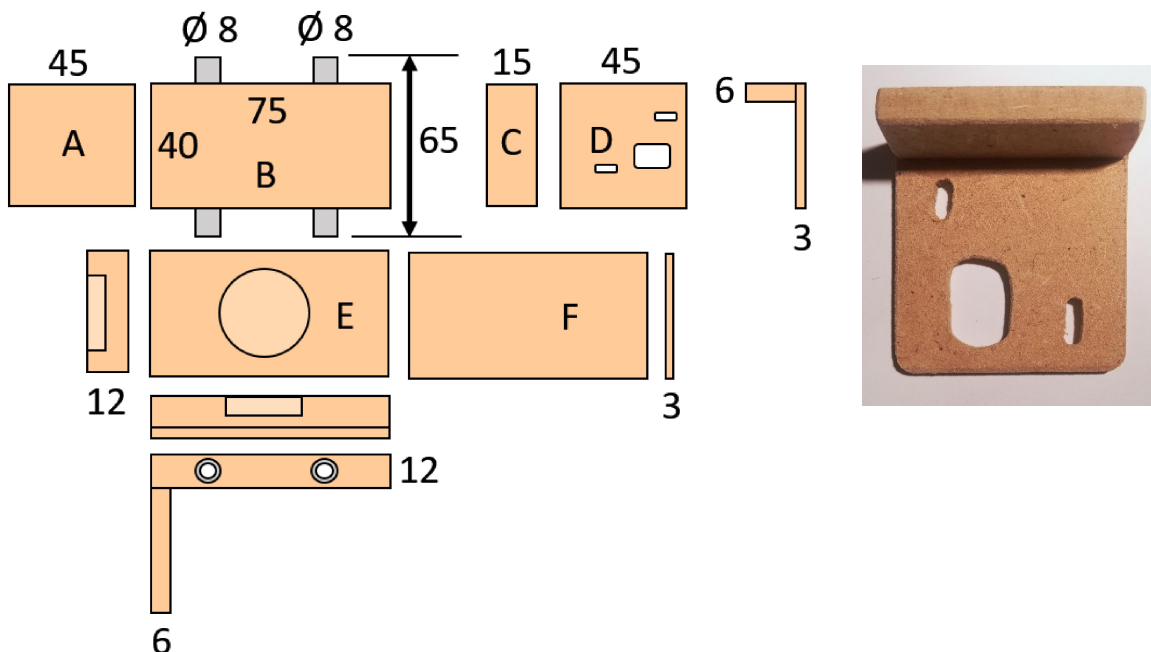

Carefully drill two 8 mm. holes perpendicularly with a pillar drill machine through the long side of part B with a center distance of 45 mm. Both holes with an equal distance from the short side. First drill with a smaller drill and finally use an 8 mm. drill, otherwise the MDF material may crack. Place the two aluminum tubes in these holes. Then glue part A to part B. Using a jigsaw, make the slotted holes in part D for the stepper motor. Make sure this motor can be adjusted up and down appr. 10 mm. Now glue part D against part C. Make a 20 mm. round hole in part E with a depth of 5 mm. for mounting the magnet and glue part F under part E. These parts are glued on part B at a later stage. When the glue has dried, mount the stepper motor on part D with two M3 bolts and attach the driver board to part A, also with two M3 bolts and two 5 mm. plastic spacers, as shown on the drawing. This is done because the ribbon cable for the connection slides underneath. Now mount the cogwheel on the shaft of the stepper motor. A plastic part was used for this, with an inner diameter of 5 mm. and an outer diameter of 8 mm. made from an alligator clip. The 8 mm. outer diameter is decreased to 6 mm. using the pillar drill machine to fit inside the cogwheel. This part is clamped in the cogwheel and secured to the motor shaft with a small screw. Then bolt the motor mounting plate C under part A with the cogwheel centered in the

longitudinal direction between both aluminum tubes. Use an M3 countersunk headed bolt because the plate F&E will be glued onto part A later. Then mount two microswitches against part C under part A with small wood screws with the contact arms protruding just outside part A.

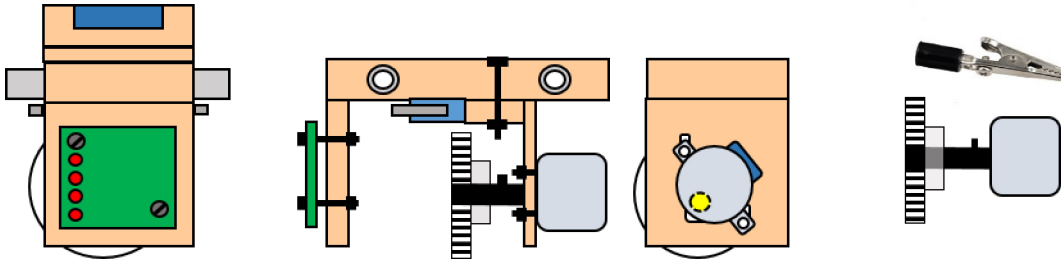

Now slide the complete motor drive onto the steel rods of the carriage and mark the path the cogwheel travels from left to right on the bottom plate. Glue the 250 mm. toothed rack along this marking and adjust the height of the stepper motor so the cogwheel and the toothed rack touch without excessive friction. Then secure the stepper motor in this position. Finally, mount M3 bolts in the X-carriage on both sides exactly where they can touch the switch arms of the micro switches for proper software detection of the end positions of the carriage.

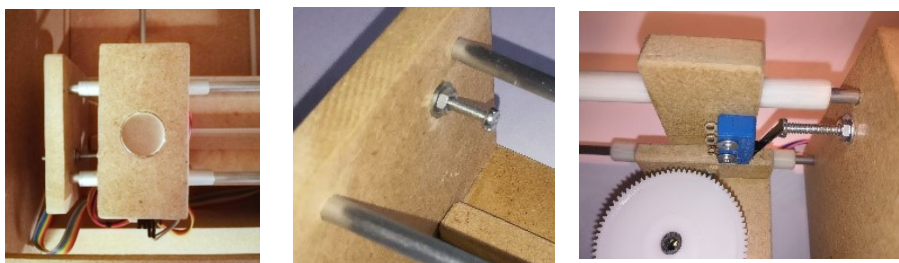
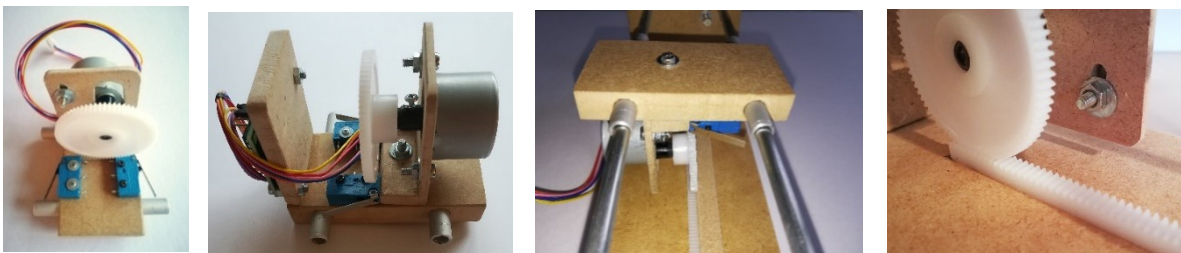
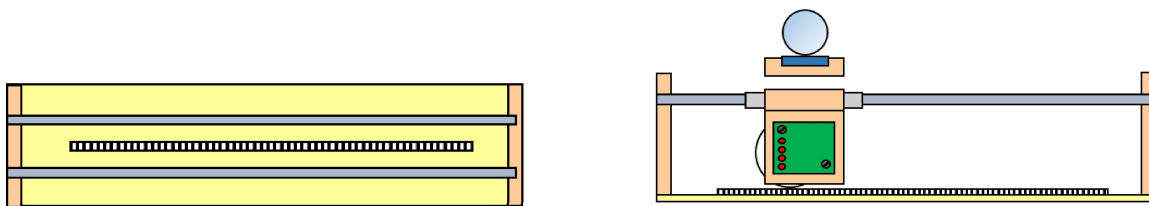

## THE Y-CARRIAGE

The following components are required:

MDF:

A base plate 320x75 mm. 6 mm. thickness.

B, C guide blocks, each 40x40 mm. 12 mm. thickness.

Other parts:

2 aluminum tubes 8 mm. length 75 mm.

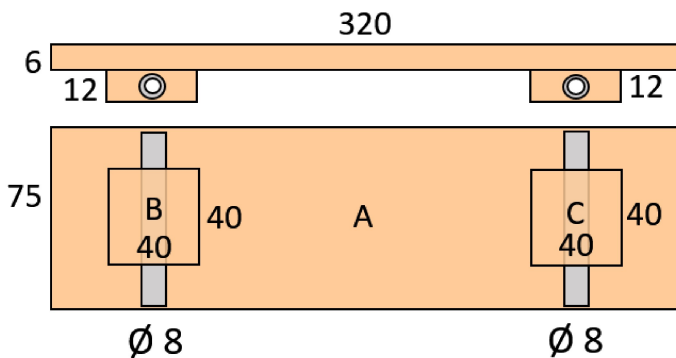

The base plate A has the same dimensions (length and width) as the base plate of the X-carriage. Carefully drill an 8 mm. hole with a drill press perpendicularly through the center of the side of both guide blocks B and C. First do this with a small drill and finally with an 8 mm. drill, otherwise the MDF material may crack. Mount an aluminum tube in each block. Then mount both blocks under the base plate A as follows:

Slide both guide blocks with the aluminum tubes onto the steel rods in the housing. Shift the protruding parts of the tubes so they protrude equally on both sides. Then press the tubes against the inside of the front. Apply wood glue to the top of the guide blocks and then rest the base plate on top with the long side also pressed against the inside of the front of the housing. The short sides must both have the same distance from the side walls of the housing. In this way, the guide blocks are neatly aligned to the base plate and the center distance is well-matched to the center distance of the steel rods. Now they can slide without friction. Let the glue dry completely without shifting the assembly.

## THE MOTOR DRIVE FOR THE Y-CARRIAGE

The following components are required:

MDF:

A top plate 70x50 mm. 6 mm. thickness.

B motor plate 50x60 mm. 3 mm. thickness.

C driver plate 54x50 mm. 6 mm. thickness.

D micro switch plate 20x80 mm. 9 mm. thickness.

Other parts:

1 insulated alligator clip to mount the cogwheel.

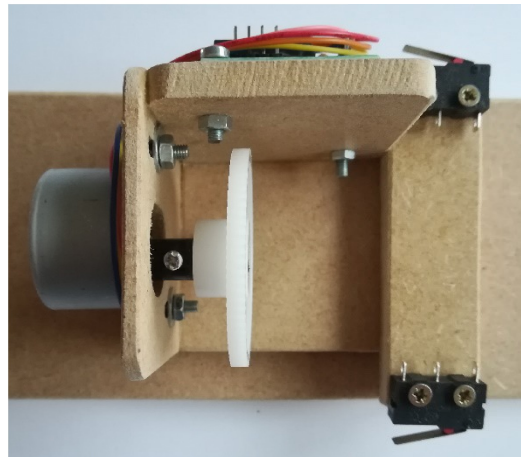
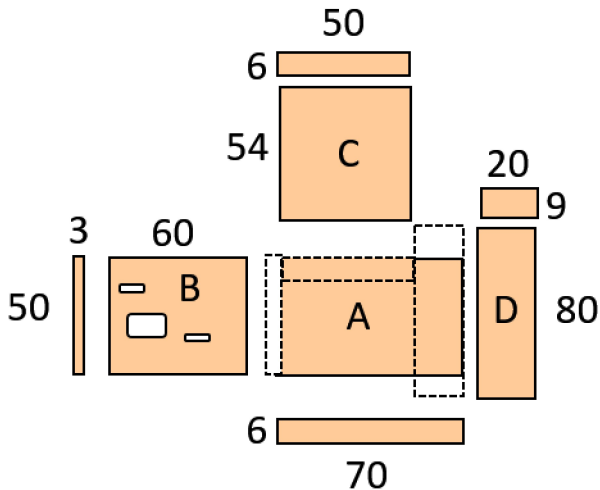

Using a jigsaw, make the slotted holes in part B for the stepper motor. Make sure this motor can be adjusted up and down appr. 10 mm. Now glue part B to part A and part C to part A and to part B as shown on the drawing. Glue part D to part A letting it protrude 15 mm. on both sides. Once the glue has dried, mount the stepper motor according to the drawing to part B with two M3 bolts and attach the driver board to part C, also with two M3 bolts and two 5 mm. plastic spacers. This is done because the ribbon cable for the connection slides underneath. Now mount the large cogwheel on the shaft of the stepper motor with a plastic part, in the same way as done for the motor drive for the X-carriage. Then mount two microswitches onto part D with small wood screws with the contact arms protruding just outside part A. Then screw the top plate A under the base plate A so the cogwheel is centered in the longitudinal direction between the aluminum tubes. Use an M3 countersunk headed bolt because the X-carriage is mounted on top of the base plate A.

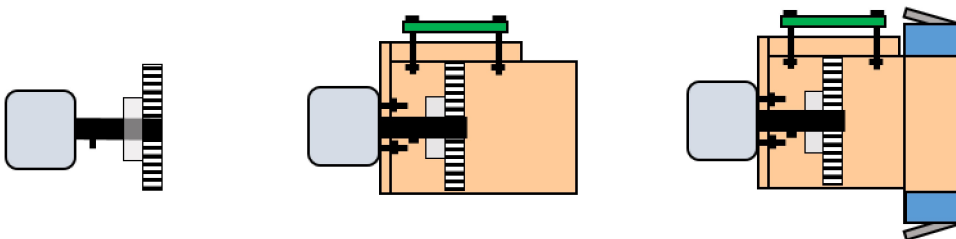

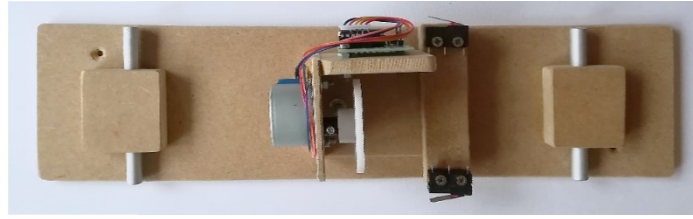
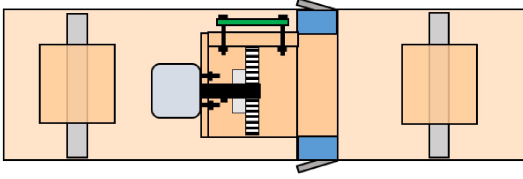

Now slide the base plate of the Y-carriage onto the steel rods in the housing and mark on the bottom plate the path the cogwheel travels from front to back. Glue the 250 mm. teathed rack along this marking. Adjust the stepper motor in height so the gear and the rack touch without excessive friction. Then secure the stepper motor in this position. Mount the base plate of the X-carriage with two M3 bolts on the base plate of the Y-carriage. Using the 2.5 sq mm. bare copper wire, make two extension brackets with a round bent ending as shown in the photo and attach them to the arm of the micro-switches of the Y-carriage with a piece of heat shrink tubing of 4mm. diameter. Glue two small wooden blocks on the inside of the housing where these brackets meet exactly in the end position. Finally, secure the ribbon cable of the Y-carriage with a wooden block on the inside of the housing so it cannot block the carriage.

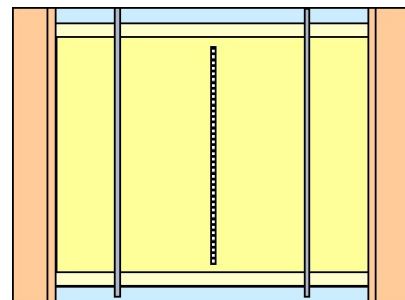
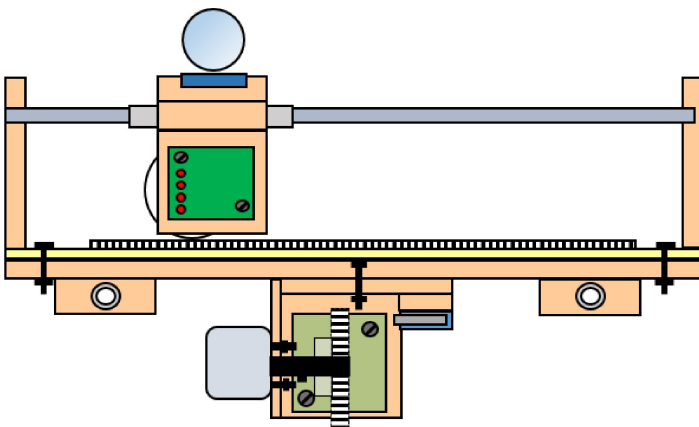
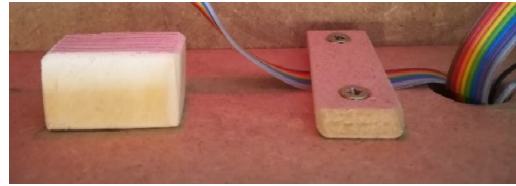
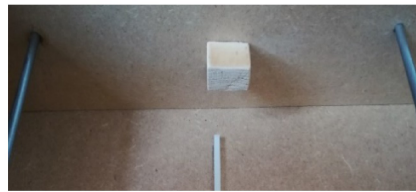
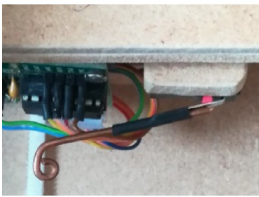

## THE CONTROL PANEL

The following components are required:

MDF:

A bottom plate 188x75 mm. 12 mm. thickness.

B, C side plates each 75x70 mm. 6 mm. thickness.

D front plate 70x200 mm. 6 mm. thickness.

E cover with menu 81x200 mm. 3 mm. thickness.

Pinewood slat:

F slat 18x18 mm. length 200 mm.

G, H slat each 18x18 mm. length 57 mm.

Other parts:

Color print of the menu 200x81 mm.

Clear adhesive film to protect the menu.

Metal ring 30 mm. with 8.5 mm. hole.

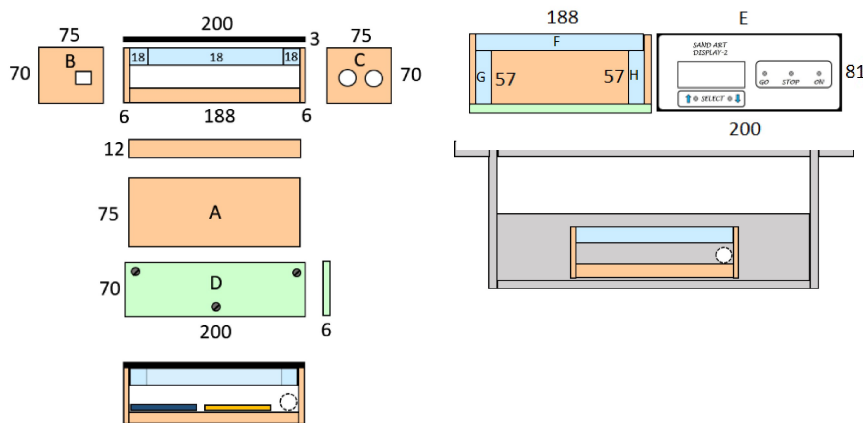

Drill three 3.5 mm. holes in the bottom plate A for mounting the Arduino, the USB connection must protrude through the left side of plate B. Mark this spot in this side plate and drill and file this hole. Also drill the two holes on the right side plate C for the mounting of the power plug and the fuse holder. The power plug is mounted on a metal ring because the wood is too thick for the fixing nut of this plug. Glue the ring on the outside to the side plate C. Mark on the front of the housing in the middle and 10 mm. under the top a rectangle, width 200 mm. and height 70 mm. Glue the strip F against the front within the top of this rectangle and glue the bottom plate A perpendicularly on the bottom of this rectangle. Also glue the side plates B and C within this rectangle on the front of the housing. When the glue has dried, drill a 15 mm. hole in the bottom right corner of the control panel in the housing for the ribbon cables for both carriages and the wiring for the LED lighting. Secure the front plate D with three wood screws.

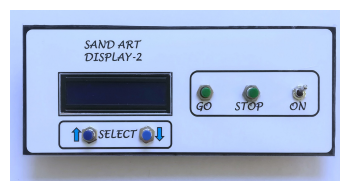
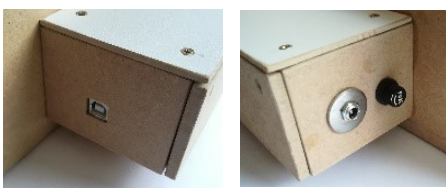

The full-size control menu.

Print this on glossy photo paper and glue it on the cover E. Add adhesive plastic foil over it for protection. Drill and file the holes for the LEDs and the switch/push buttons.

Dimensions of the holes: toggle switch: 6 mm, LED holders: 8 mm, push buttons: 7 mm.

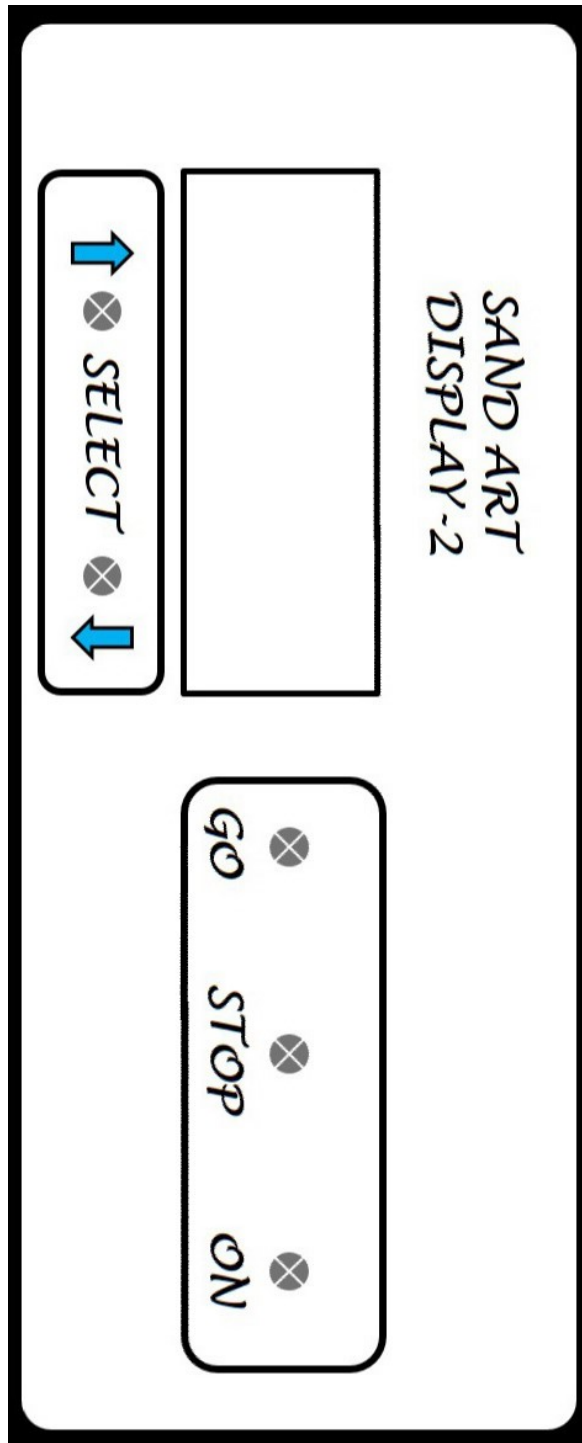



# THE WIRING

The connection diagram:

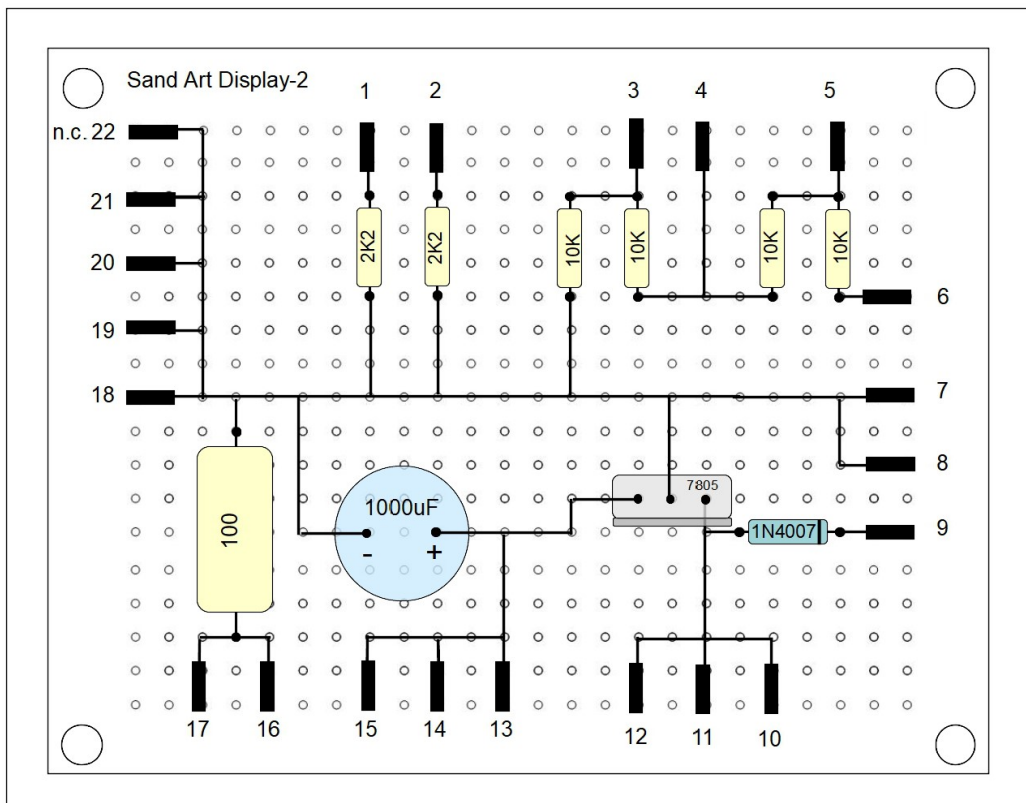
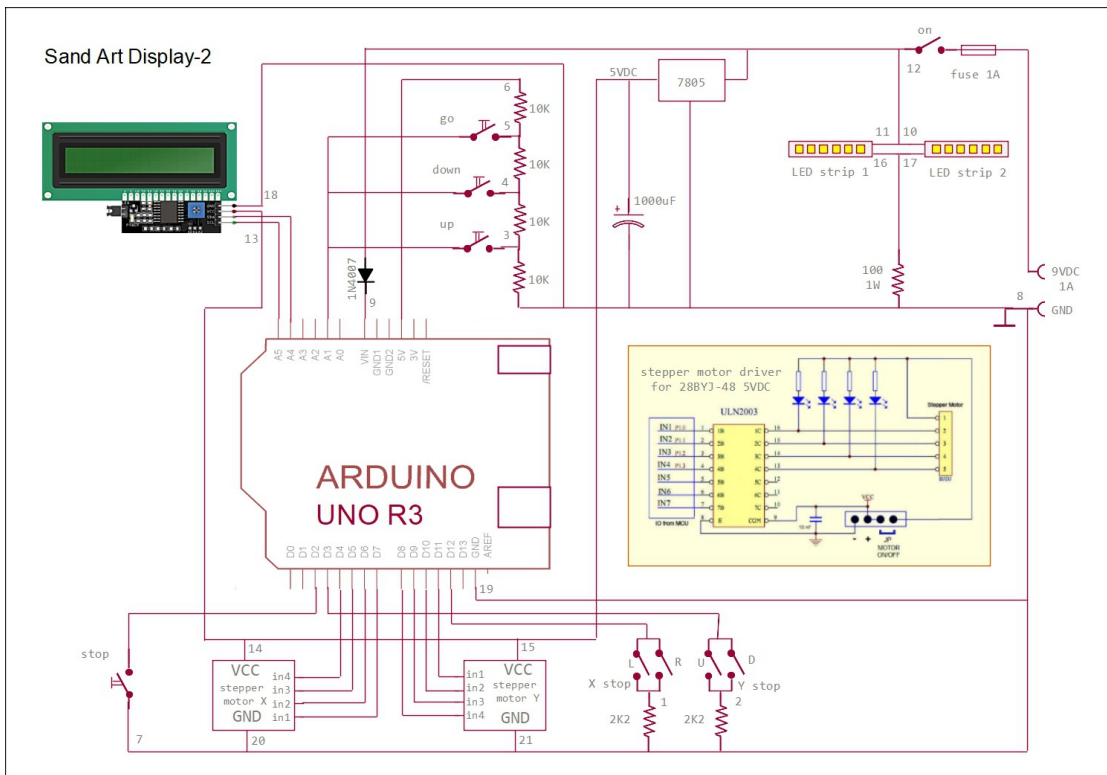

Mount the Arduino in the control panel with three M3 bolts, using one nylon spacer. Mount the parts on the PCB according to drawing. Solder the connections for the wiring at the top side of the PCB so the wiring can be connected easy. Mount it next to the Arduino on the bottom plate of the control panel with four wood screws using M3 nuts as spacers.

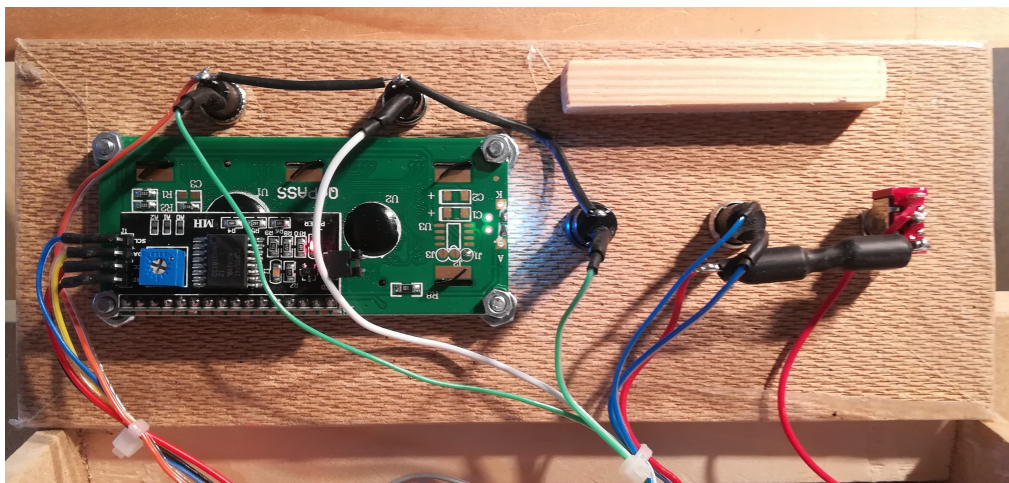
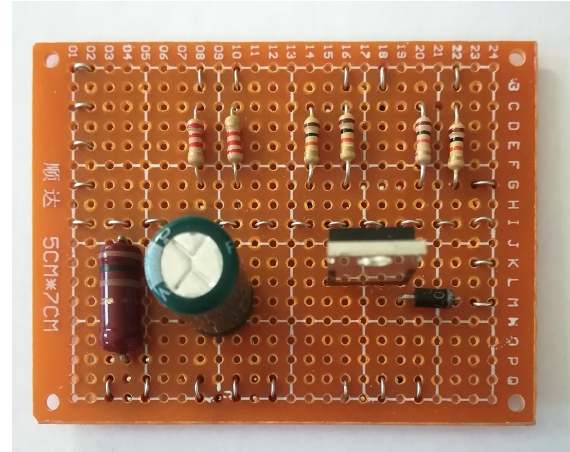
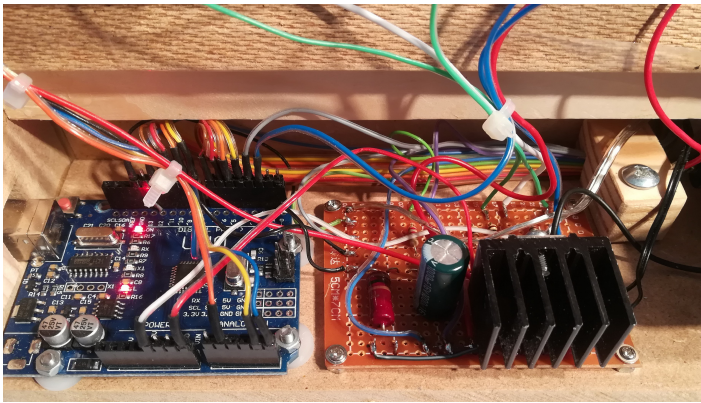

Glue a pinewood slat 9x9 mm. to the bottom of the lid with a length of 100 mm. to lock the lid so it fits snugly.

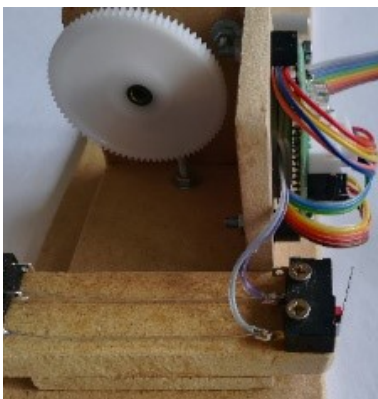

For the connection of the stepper motors use a piece of ribbon cable with a length of appr. 50 cm, split it into 2 pieces with 8 cores. Solder these to the pins of the two driver boards and to the NO contacts of the micro switches. Wire the two micro switches of each slide in parallel with their NO contacts with the thin bare mounting wire. Neatly insulate the soldered terminals on the pins of the driver boards with the 1 mm. heat shrink tubing. Guide the ribbon cables under the driver boards, secured with a few pieces of double-sided tape. To do this, first disassemble the driver boards. The connections on the Arduino are made with the connection pins to which the wires are soldered. Also insulate these pins neatly with the 1 mm. heat shrink tubing. Lock the ribbon cables coming in from the slides with a small block of pinewood in which a vertical slot has been sawn. Fix this block to the bottom plate with a wood screw. For all further wiring, use split single wires taken from the ribbon cable, except the wiring for connecting the power plug to the fuse holder, from the fuse holder to the toggle switch, from the toggle switch to the PCB and for the ground connection of the power plug to the PCB. Use the 1 sq mm. red and black connection wires for these connections. Mount the heat sink on the 7805 voltage stabilizer, it can get quite hot when the sand art display is in operation for a long time.

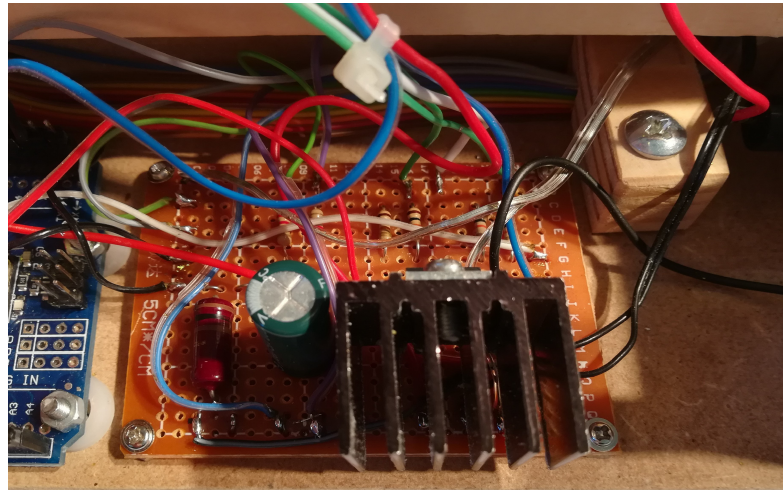
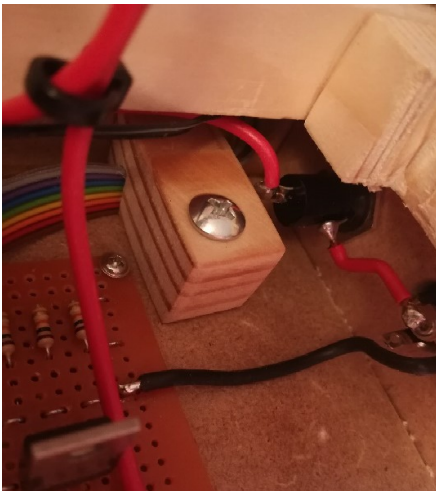

## THE SOFTWARE

The Arduino sketch can be downloaded from the website [www.apinventions.wordpress.com](http://www.apinventions.wordpress.com)

With this software, many possible patterns can be created.

The basic principles for the hardware connection on the Arduino are as follows:

Stepper motor for the X direction: port D8, D9, D10, D11.

Stepper motor for the Y direction: ports D4, D5, D6, D7.

Switches for selection port A1, maximum analog value is 1023.  
up=390, down=621, go=810.

Switches for end position detection X-carriage: port D12, Y-carriage: port D3.

Set ports A1, D2, D3 and D12 in the setup as INPUT\_PULLUP.

After switching on, the metal ball first goes to the top left starting position and then a pattern can be selected using the UP/DOWN buttons and the display.

Press GO and the the pattern will be drawn. The sequence can be interrupted anytime by pressing the STOP button. The metal ball will return to the starting position in the left/top corner until another pattern is selected and started.

