

APROBADO PARA CONSTRUCCION

FECHA: \_\_\_\_\_ FIRMA: \_\_\_\_\_ CUENTE

FECHA: \_\_\_\_\_ FIRMA: \_\_\_\_\_ JRGR

▲				
▲				
▲				
▲				
▲				
▲	PLANOS GENERALES PARA SU APROBACION			

REVISIONES	POR	APROB.	FECHA

CLIENTE: \_\_\_\_\_  
CLIENTE: \_\_\_\_\_

**UNIVERSIDAD POLITECNICA DE SLP**  
Urbano Villalón 500, Col. La Ladrillera, 78369  
TEL.: 01 444 812 6367  
SAN LUIS POTOSI, S.L.P.

RG. COMPANY Elgalindo\_94@hotmail.com

TITULO  
**CATAPULTA**

CLIENTE: UPSLP

No. DE PROYECTO \_\_\_\_\_  
NO. ORDEN COMPRA \_\_\_\_\_

DIB. ING. RAMON GALINDO  
FECHA: 20/10/2015  
ESCALA: 1:3  
NO. PLANO CTA-201015-01

ACOTACIONES: mm.  
PROYECCION: REVISION

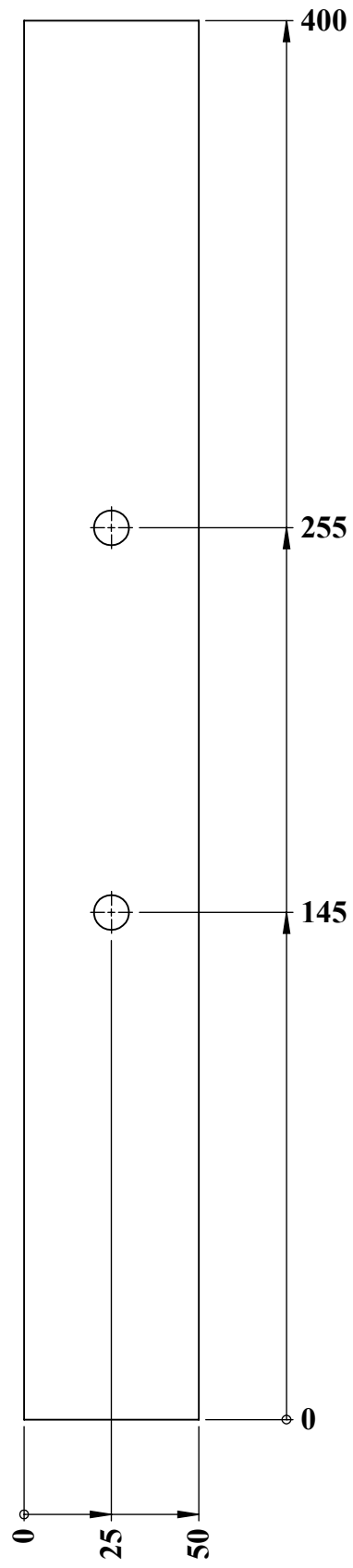

**POS. 01**

MAT.: MADERA  
□ 30 x 50 x 200  
REQ. 2 PZA.

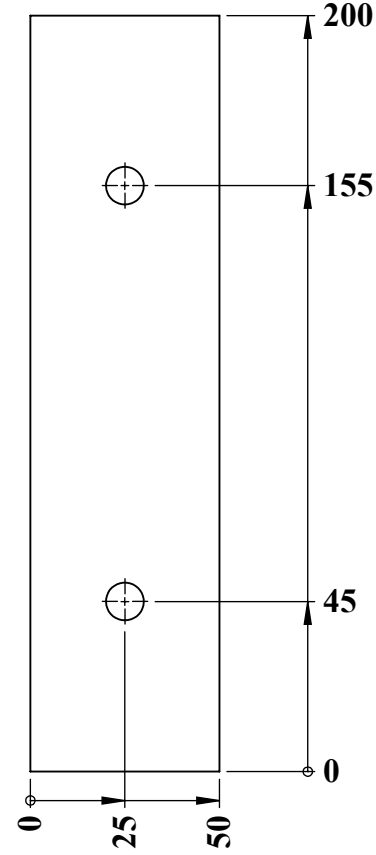

**POS. 02**

MAT.: MADERA  
□ 30 x 50 x 200  
REQ. 2 PZA.

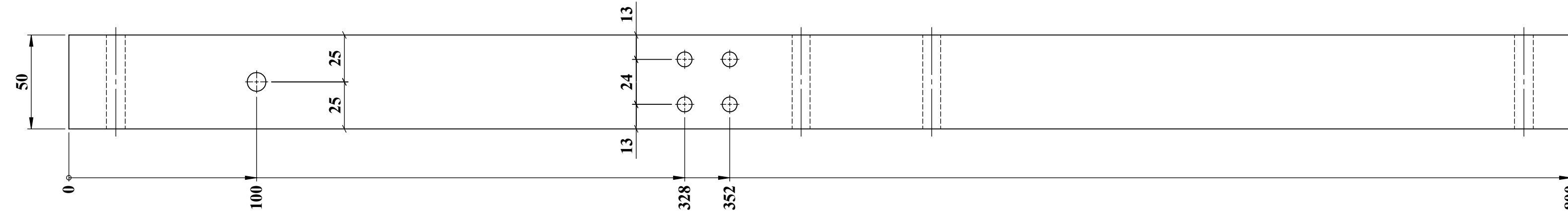
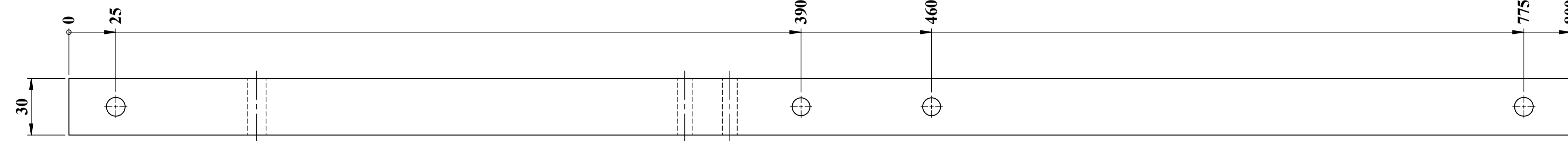

**POS. 03**

MAT.: MADERA  
□ 30 x 50 x 800  
REQ. 2 PZA.

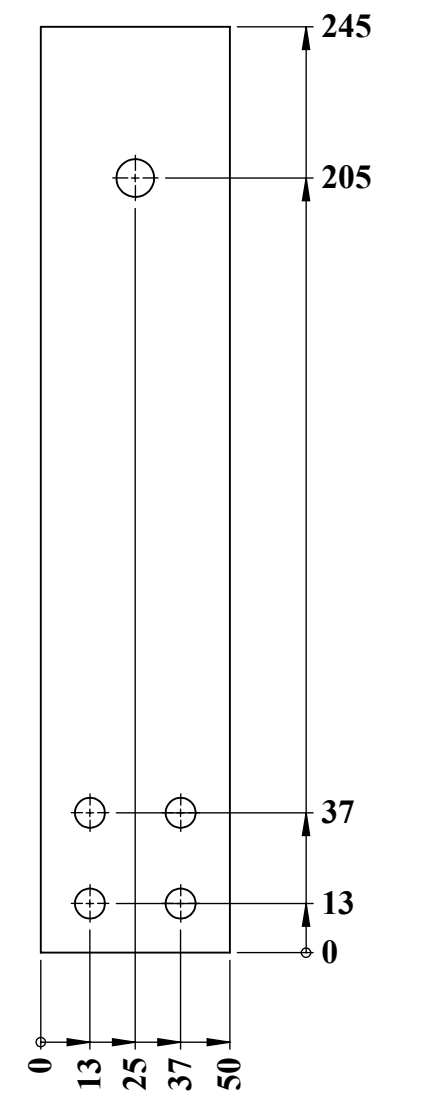

**POS. 04**

MAT.: MADERA  
□ 30 x 50 x 245  
REQ. 2 PZA.

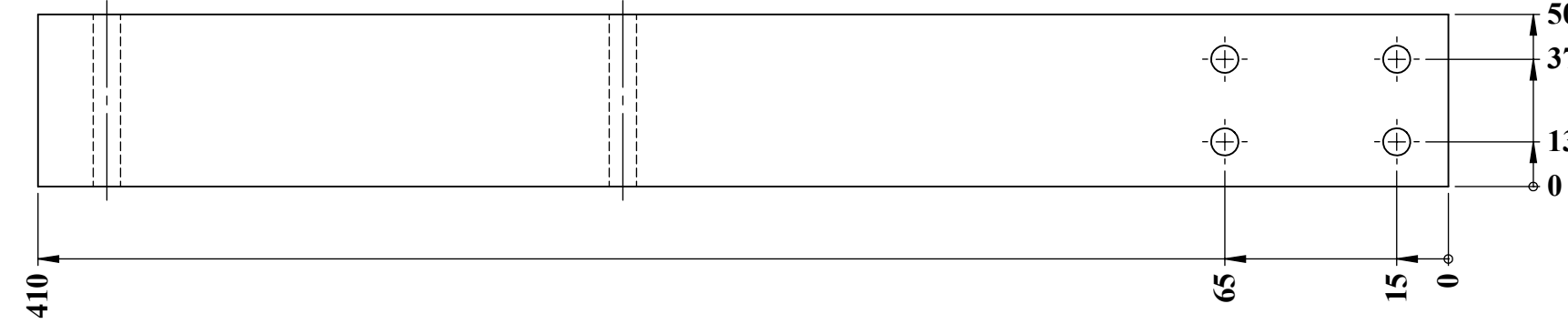
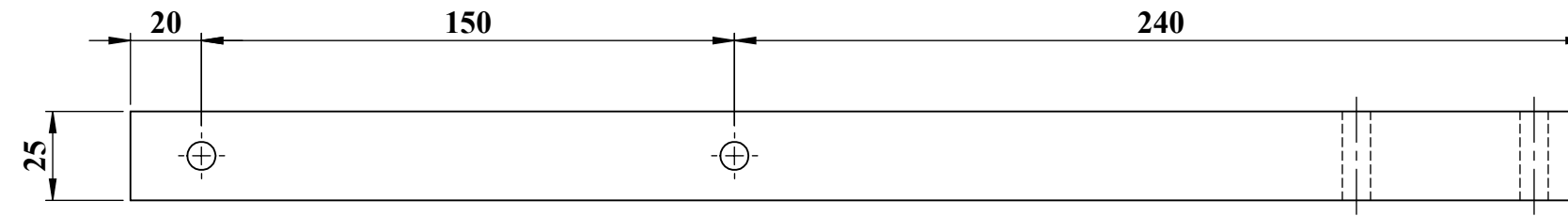

**POS. 06**

MAT.: MADERA  
□ 25 x 50 x 410  
REQ. 1 PZA.

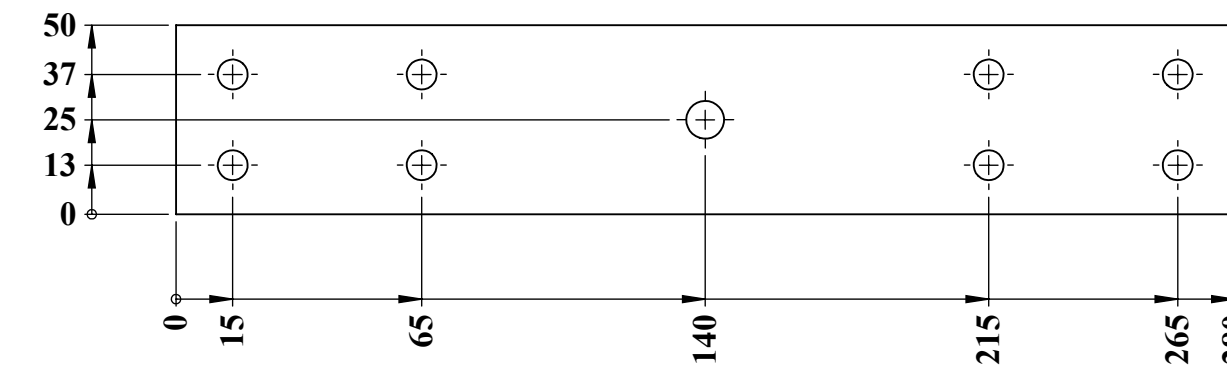

**POS. 08**

MAT.: MADERA  
□ 25 x 50 x 280  
REQ. 2 PZA.

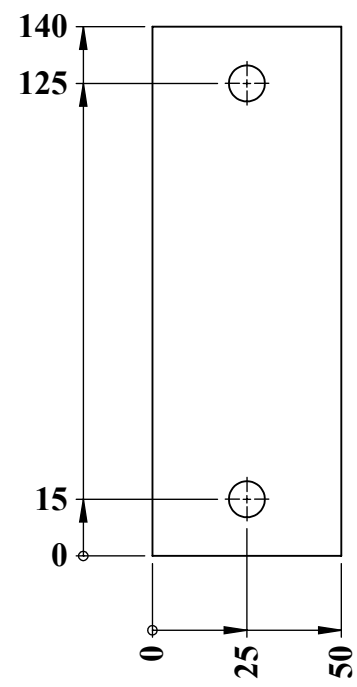

**POS. 05**

MAT.: MADERA  
□ 30 x 50 x 140  
REQ. 1 PZA.

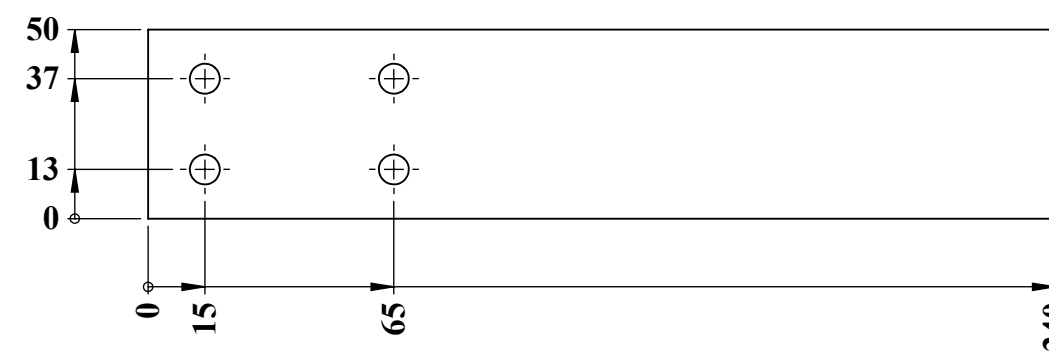

**POS. 07**

MAT.: MADERA  
□ 25 x 50 x 240  
REQ. 1 PZA.

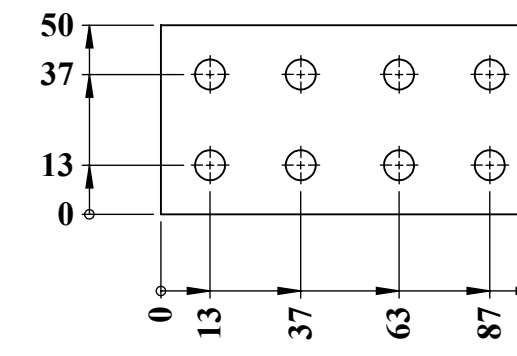

**POS. 09**

MAT.: METAL  
□ 1/4" x 50 x 100  
REQ. 2 PZA.

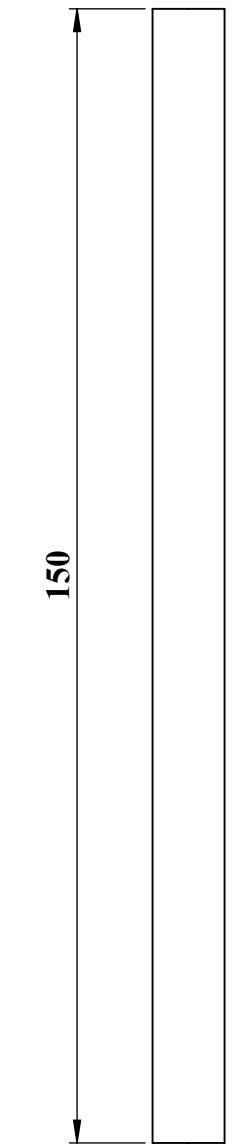

**POS. 10**

MAT.: MADERA  
∅ 3/8" x 150  
REQ. 2 PZA.

APROBADO PARA CONSTRUCCION

FECHA: \_\_\_\_\_ FIRMA: \_\_\_\_\_ CUENTE

FECHA: \_\_\_\_\_ FIRMA: \_\_\_\_\_ JRGR

△				
△				
△				
△				
△				
△	PLANOS GENERALES PARA SU APROBACION			
	REVISIONES			
		POR	APROB.	FECHA

CLIENTE:	
CLIENTE:	



**UNIVERSIDAD POLITECNICA DE SLP**  
Urbano Villalón 500, Col. La Ladrillera, 78369  
TEL.: 01 444 812 6367  
SAN LUIS POTOSI, S.L.P.

RG. COMPANY    Elgalindo\_94@hotmail.com

NO. DE PROYECTO	DIB. ING. RAMON GALINDO
NO. ORDEN COMPRA	FECHA: 20/10/2015

<b>TITULO</b>		<b>CATAPULTA</b>	
CLIENTE: UPSLP		ESCALA: 1:2	ACOTACIONES: mm.
NO. PLANO	CTA-201015-02	PROYECCION:	REVISION