

This circle prevents arm from getting caught on tabs. No tabs are glued onto this circle.

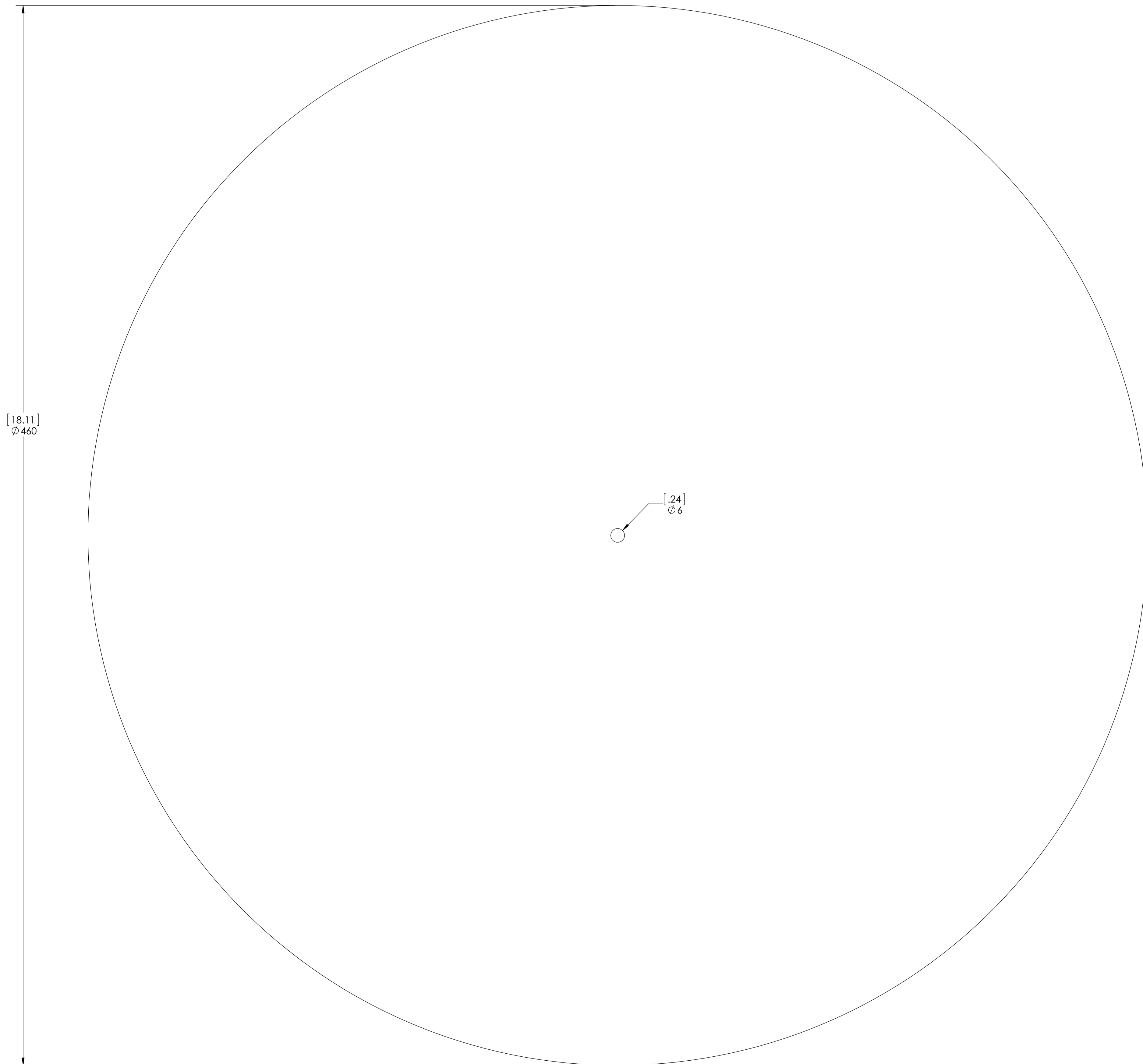

UNLESS OTHERWISE SPECIFIED: DIMENSIONS ARE IN MILLIMETERS		FINISH:		DEBUR AND BREAK SHARP EDGES		DO NOT SCALE DRAWING		REVISION	
SURFACE FINISH:									
TOLERANCES:									
LINEAR:									
ANGULAR:									
DRAWN:		NAME	SIGNATURE	DATE				TITLE:	
CHK'D:									
APP'VD:									
MFG:									
Q.A:									
		MATERIAL:		DWG NO.		SCALE:1:1		A1	
		WEIGHT:		SHEET 1 OF 9					

Need 2 semi-circles

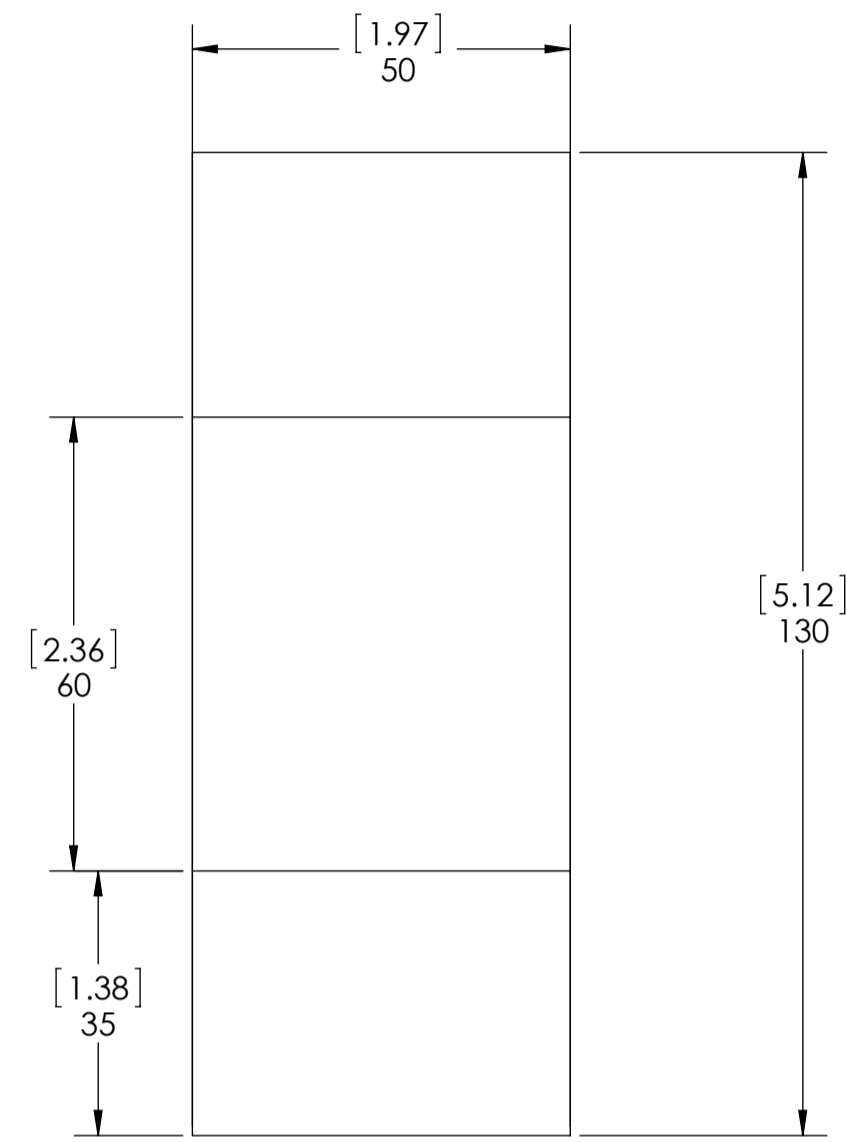

Need 16 tabs  
- 9 for large semi-circles  
- 7 for small semi circles

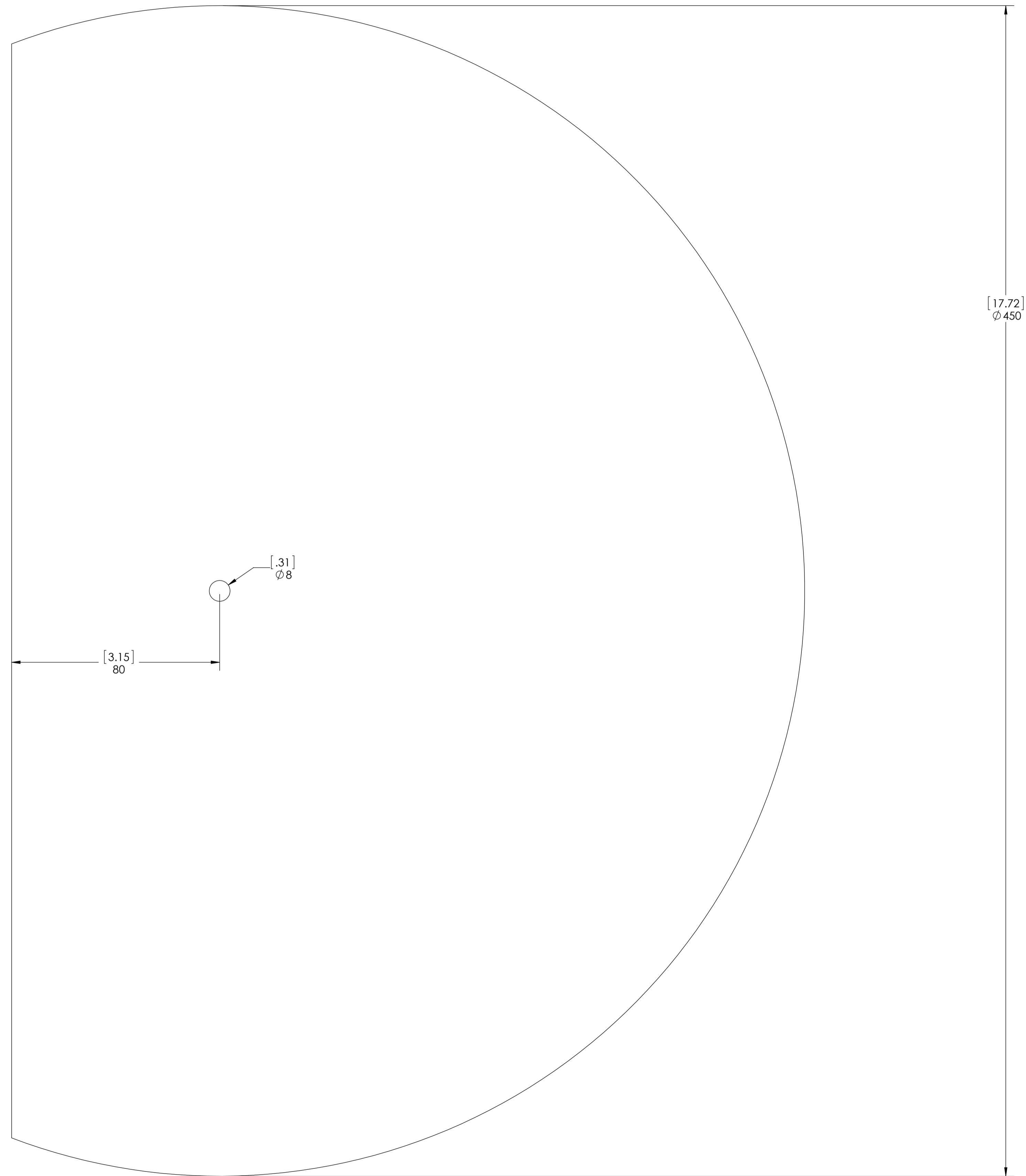

UNLESS OTHERWISE SPECIFIED: DIMENSIONS ARE IN MILLIMETERS		FINISH:		DEBUR AND BREAK SHARP EDGES		DO NOT SCALE DRAWING		REVISION	
SURFACE FINISH:									
TOLERANCES:									
LINEAR:									
ANGULAR:									
DRAWN:	NAME:	SIGNATURE:	DATE:			TITLE:			
CHKD:									
APPVD:									
MFG:									
QA:									
						MATERIAL:	DWG NO.	CBR - final	
						WEIGHT:	SCALE:1:1	SHEET 2 OF 9	

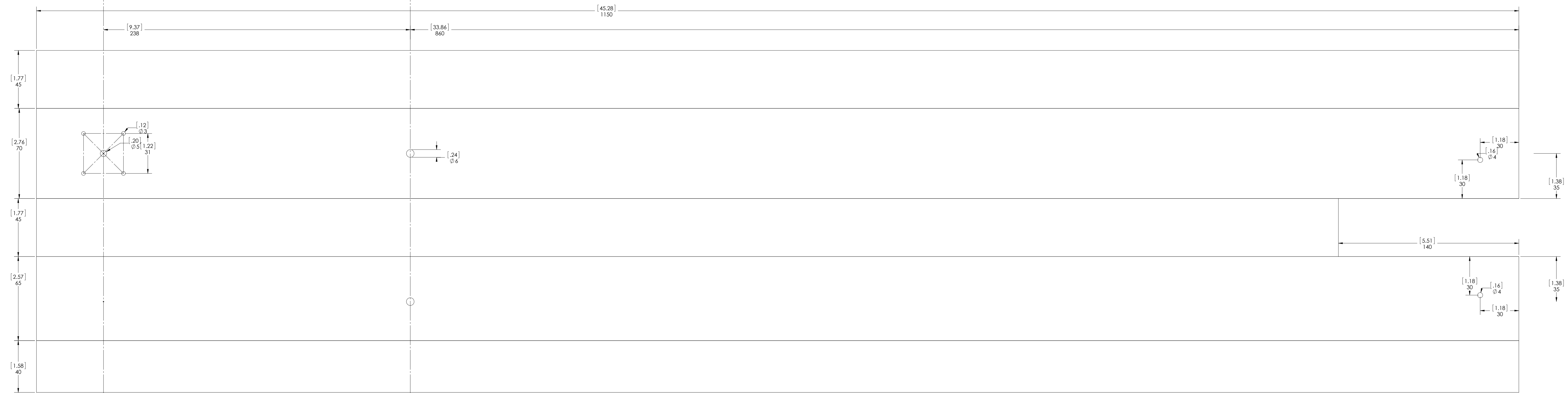

This is the main arm that bears most of the load. Motor 1 is attached on the left.



UNITS OR DIMENSIONS SPECIFIED:		INCH	DESIK AND	DO NOT SCALE DRAWING	REVISION
DIMENSIONS ARE IN MILLIMETERS			BEKAS SWAMP		
DRAWING NUMBER			0000		
PROJECT NAME					
DATE					
NAME	SIGNATURE	DATE			FILE:
DESIGNER					
CHECKED					
APPROVED					
DATE					
MATERIAL					
DRAWING NO.					
SCALE: 1:1					
PROJECT					
SHEET # OF #					

This is the arm to which the claw or camera mount is attached to.



UNITS SPECIFIED:		INCH	DIN/ISO AND MKS/SAE SHARP EDGES		DO NOT SCALE DRAWING	REVISION
DRAWN BY:			DATE:			TITLE:
CHECKED BY:			DATE:			
APPROVED BY:			DATE:			
MATERIAL:			DRAWING NO.:			
SCALE:			SHEET NO.:			



This is the counter-weight that attaches to the main arm on the same side as Motor 1.  
 Add approximately 1 kg of pebbles or sand in a zip-lock bag.  
 The counter-weight will help the robot pick up heavier loads.

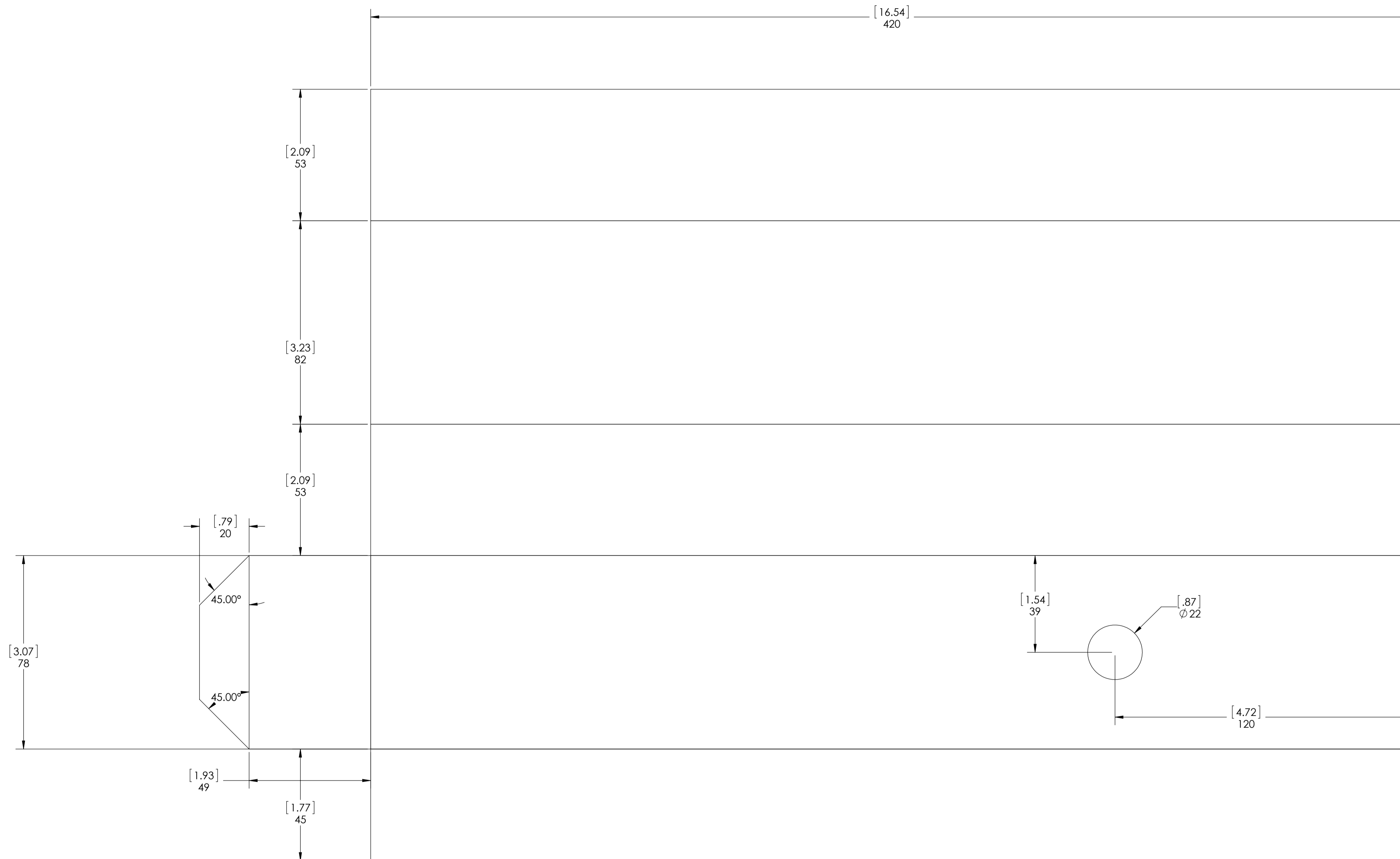

UNLESS OTHERWISE SPECIFIED: DIMENSIONS ARE IN MILLIMETERS		FINISH:		DEBUR AND BREAK SHARP EDGES		DO NOT SCALE DRAWING		REVISION	
SURFACE FINISH:									
TOLERANCES:									
LINEAR:									
ANGULAR:									
DRAWN:		NAME:	SIGNATURE:	DATE:		TITLE:			
CHK'D:									
APP'VD:									
MFG:									
Q.A:						MATERIAL:		DWG NO. <b>CBR - final</b>	
						WEIGHT:		SCALE 1:1	
								SHEET 7 OF 9	

This semi-circle prevents motor from catching on tabs. No tabs are glued onto this semi-circle. Only one of these are needed.

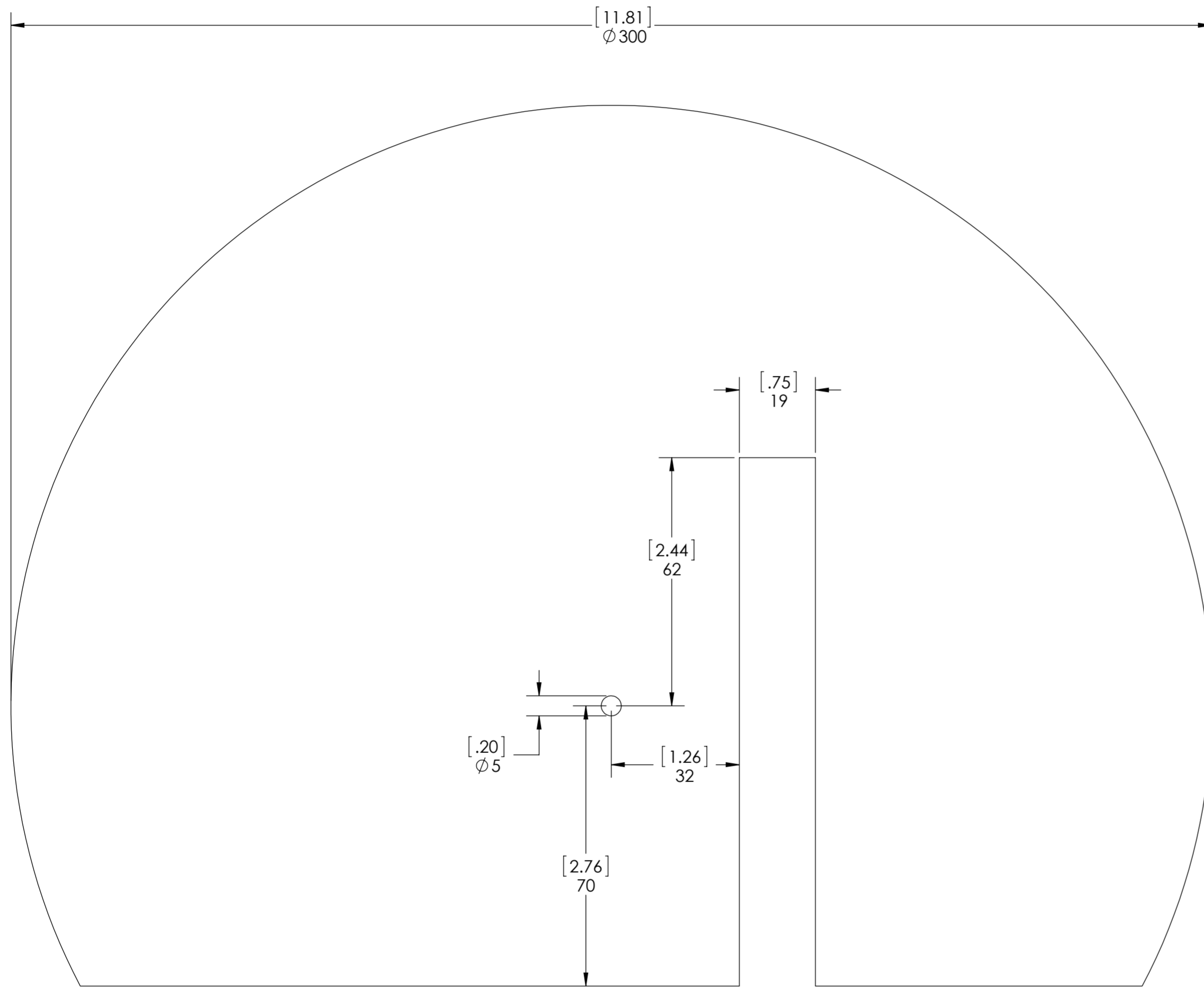

UNLESS OTHERWISE SPECIFIED: DIMENSIONS ARE IN MILLIMETERS		FINISH:		DEBUR AND BREAK SHARP EDGES		DO NOT SCALE DRAWING		REVISION	
SURFACE FINISH:									
TOLERANCES:									
LINEAR:									
ANGULAR:									
DRAWN:		NAME	SIGNATURE	DATE		TITLE:			
CHK'D:									
APPV'D:									
MFG:									
Q.A:						MATERIAL:	DWG NO.	CBR - final	
								A2	
						WEIGHT:	SCALE:1:1	SHEET 8 OF 9	



Need two of these semi-circles. Tabs are glued on to these.  
Slightly smaller than x1 semicircles. This is to give clearance for tabs.

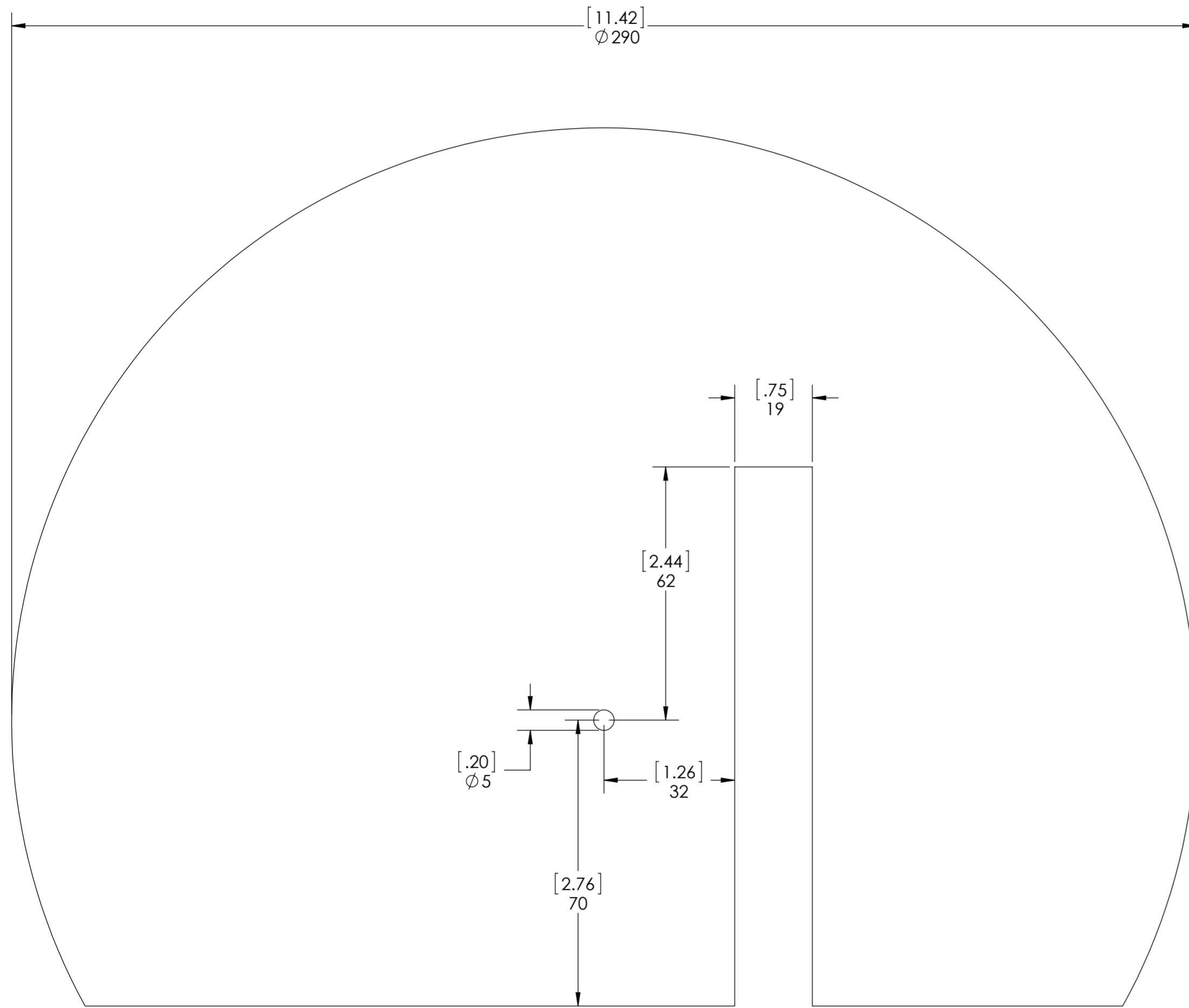

UNLESS OTHERWISE SPECIFIED: DIMENSIONS ARE IN MILLIMETERS		FINISH:		DEBUR AND BREAK SHARP EDGES		DO NOT SCALE DRAWING		REVISION	
SURFACE FINISH:									
TOLERANCES:									
LINEAR:									
ANGULAR:									
DRAWN:		NAME	SIGNATURE	DATE		TITLE:			
CHK'D:									
APP'V'D:									
MFG:									
Q.A:						MATERIAL:	DWG NO.	CBR - final	
								A2	
						WEIGHT:	SCALE:1:1	SHEET 9 OF 9	