

Find 3 parts with the same number

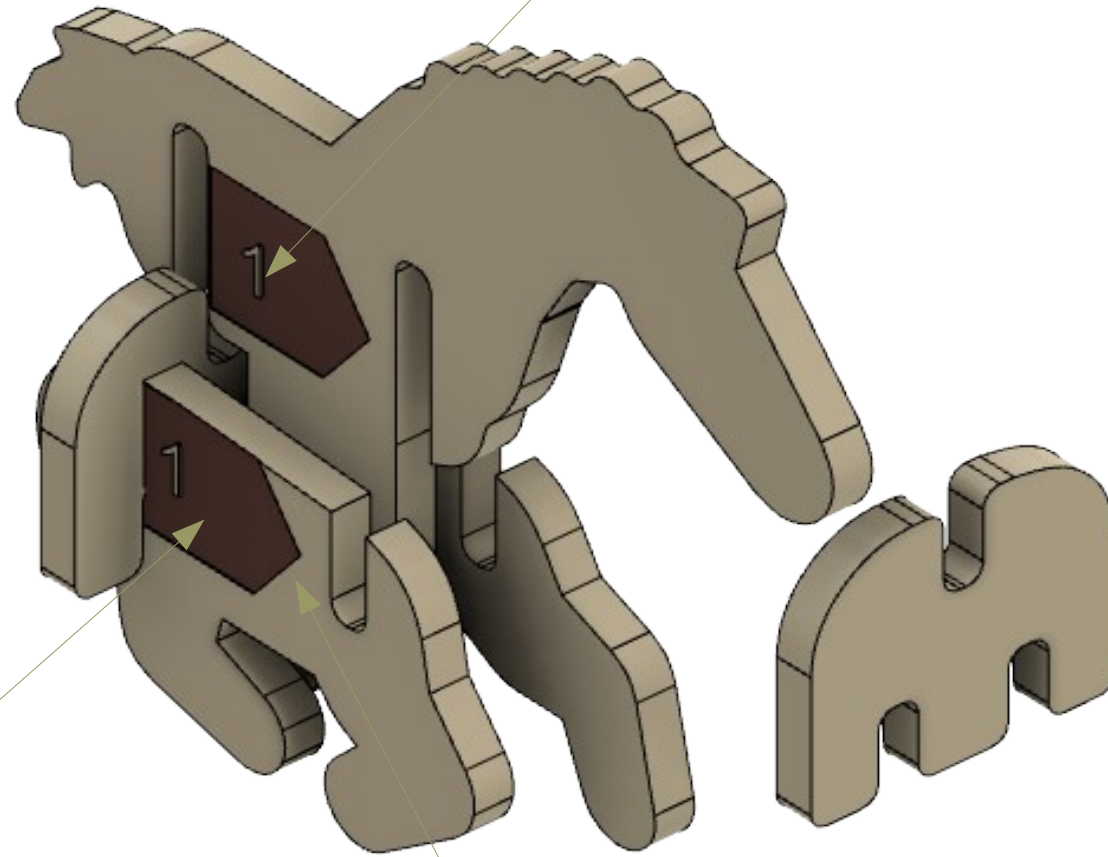

Markings on leg parts
are on the outside

All marking point forward

Arranged all ponies so that their numbers are in a counter-clockwise order.

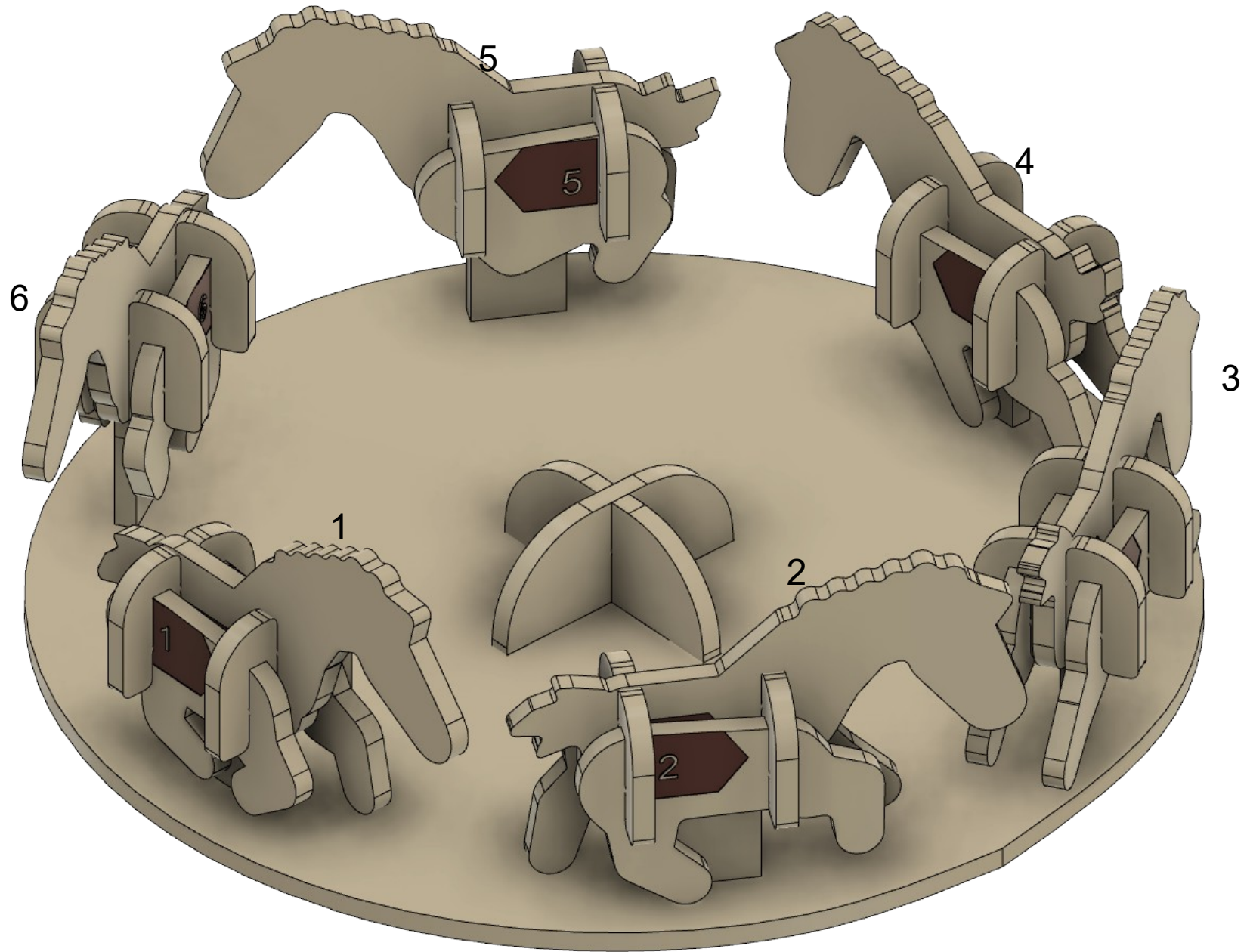

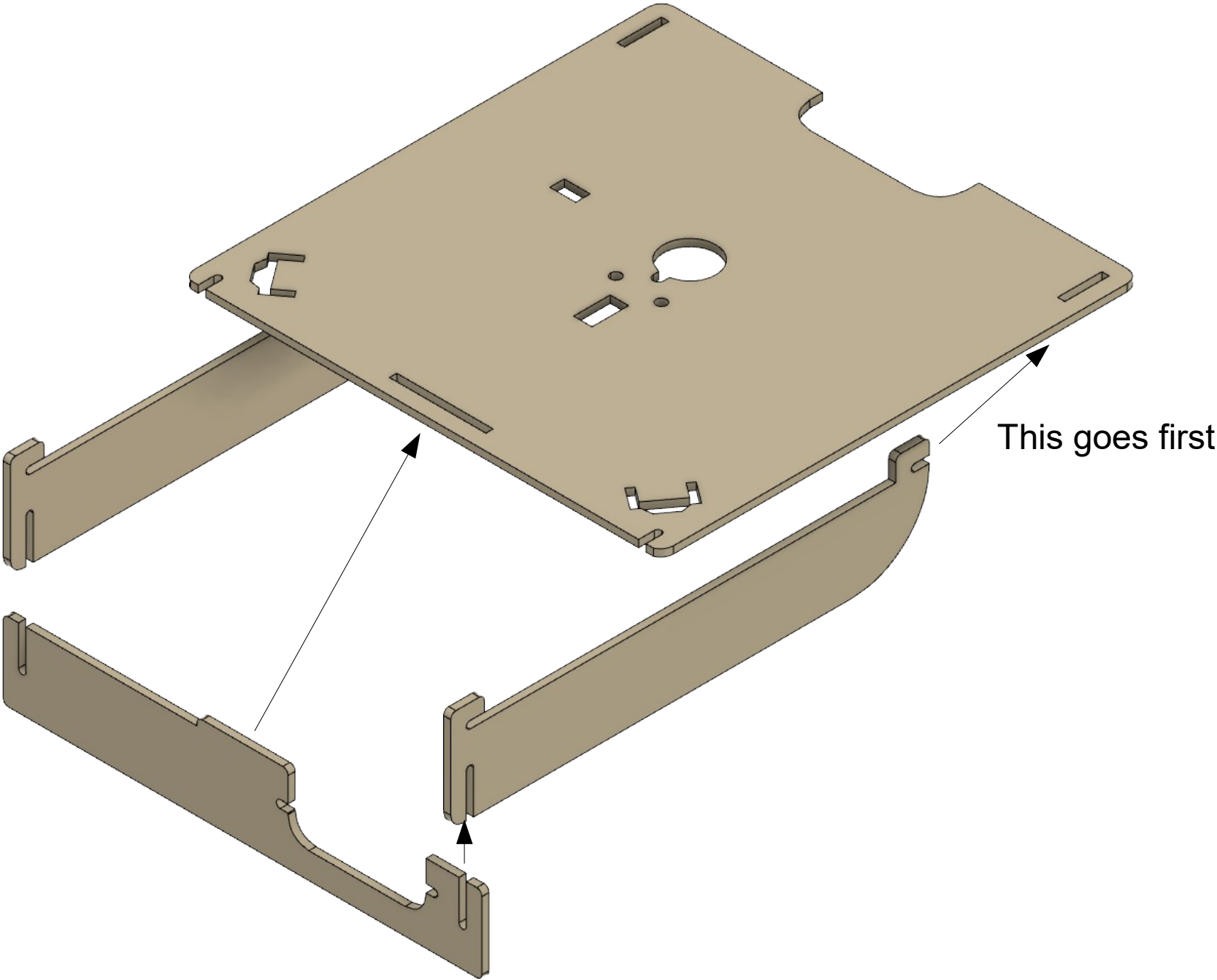

This goes first

