



Android Controlled Bluetooth Sumobot (Ultimate DIY RC! \$90)

by **ASCAS** on August 31, 2013

Table of Contents

Android Controlled Bluetooth Sumobot (Ultimate DIY RC! \$90)	1
Intro: Android Controlled Bluetooth Sumobot (Ultimate DIY RC! \$90)	2
Step 1: Tools & Materials	3
Step 2: Choosing Your Metal Gearbox	4
Step 3: Choosing Your Motor Driver	5
Step 4: Mounting The Motors	5
Step 5: Gluing The Side Panels	5
Step 6:	6
Step 7: Installing The Batteries	6
Step 8: Installing The Arduino Shields & Sensors	7
Step 9: Installing The Hood (Takes A Lot of Thinking)	8
Step 10: Installing & Knowing Your Bluetooth Module	8
Step 11: The Arduino Codes (C++)	9
File Downloads	11
Step 12: You're Done! Enjoy Your, Heavy Combat Sumobot!	11
Related Instructables	12
Advertisements	13



Author:ASCAS ASCAS.com

Angelo Casimiro: Hello! I'm an enthusiastic hobbyist like you. I started posting ibles" at 10 y/o. I'm currently 15, I'm working on some autonomous robots right now. PROUD TO BE FILIPINO! I hope you find my guides useful =)) I'm good in electronics and computer programming. I got interested in electronics and mechanics when i was 4 year old. And started soldering circuits (kits) at 7 years old. And improved soldering at 9 years old without any kit only following circuit diagrams. And started making original circuits and schematics at 12 years old. Now I'm 13, I make customized PCBs, I already made an audiophile tower speakers, a high grade amplifier and an automated solar power light managing system. Right now my new interest comes from HiFi, Pro-audio and Audiophile setups. I build HiFi amplifiers from scratch. I also build bookshelf, tower, monitor and subwoofer speakers using my trusty "Jigsaw, Sander, Drill and Wood Glue" all started from a 4x8 MDF board.

Intro: Android Controlled Bluetooth Sumobot (Ultimate DIY RC! \$90)

Time to get pushy! This week I built a \$90, Android controlled bluetooth sumobot. I finally decided to tweak my 1KG autonomous sumobot before competing in the nationals, just for fun. I added a \$8 bluetooth module. It's an Arduino-Android based, open source robot, you can pretty much do anything with it! A major code reconstruction was necessary for my hardware to work with the module.

Meet "CALSONIC" the 1KG hybrid autonomous sumobot (RC/ runned by AI), named after the Nissan skyline and lemans. I'm about to make a skyblue paintjob similar to the Nissan calsonic. The other one, is named FAC3PALM and has a green theme color.

The app is free from google-play ([Bluetooth RC Car](#)). It includes: 8 directional movements, a speed control slider, 3 toggle switches and can use the accelerometer for steering. With the proper tools & equipment you can pretty much finish this within an hour or so.

Guide Includes:

- Codes For Arduino (Explained)
- "Bluetooth RC" Android App
- Free Printable PDF (Pro not needed)

SPECS:

- Arduino UNO based (programmed with C++)
- 500-1200 RPM Metal Gearbox (High Speed & Torque)
- 30 Ampere Pololu Motor Shield (High Performance)
- 15 meter range bluetooth module (easy to use TX, RX)
- Powered by a 4 Cell recycled LiPo (Debloated Turnigy)
- 3x Sharp Proximity Sensors + 2 Ground Sensors

My Dry-run Video (Enjoy!)

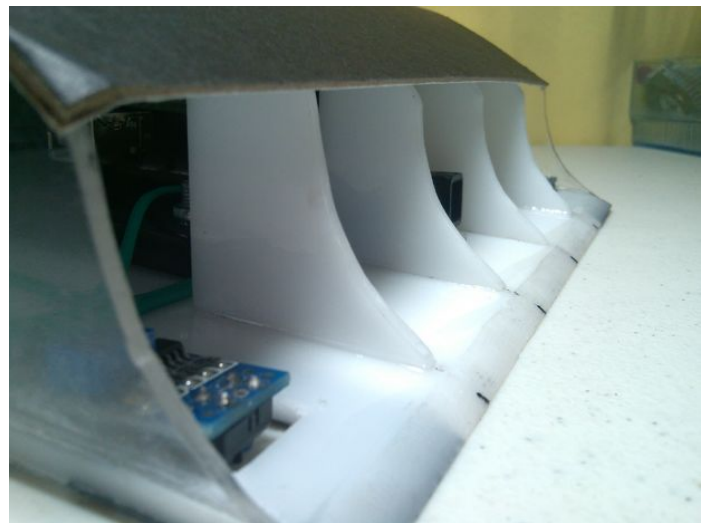
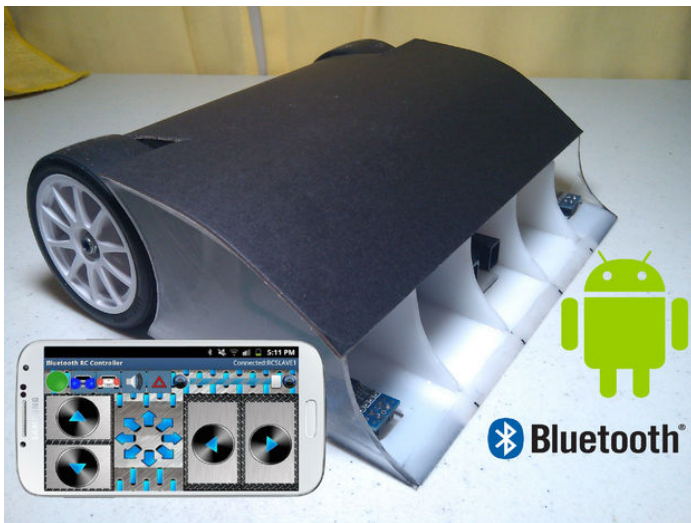

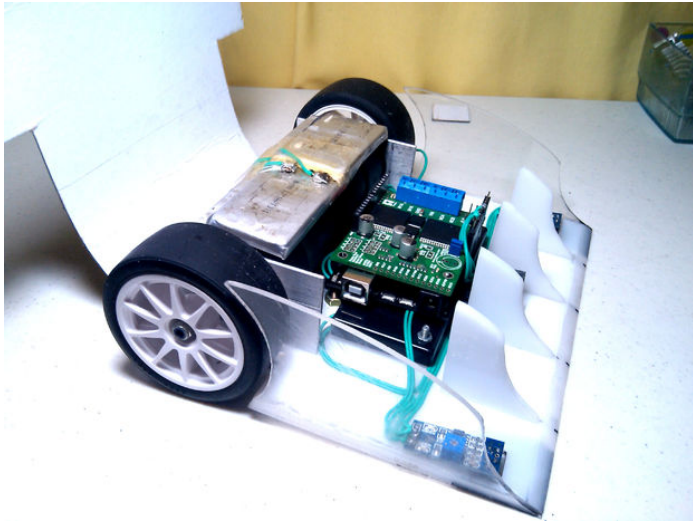
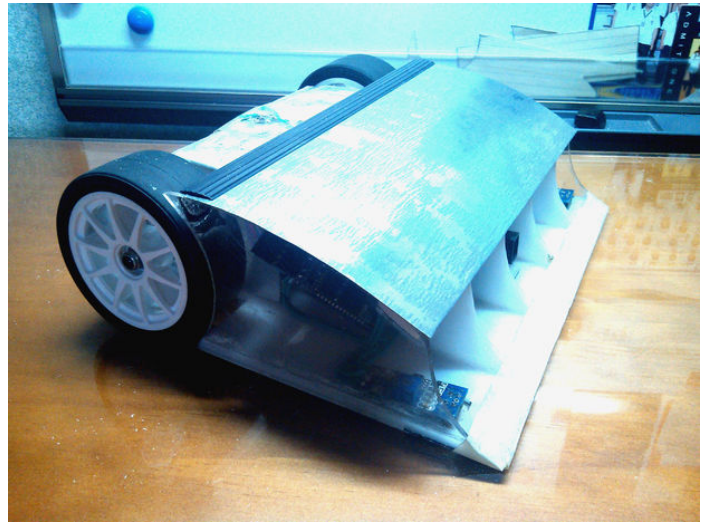
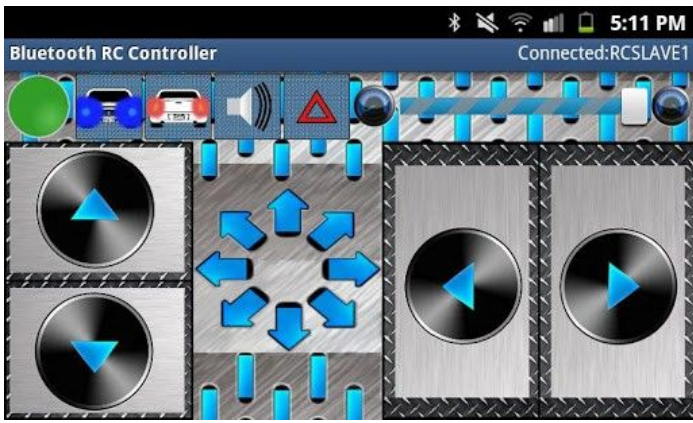

Step 1: Tools & Materials

Here's the list of my exact parts. Try to wait for a Christmas sale in Pololu.com , I saved 35% on their parts. In step 2 and 3 alternatives will be given. Click on the material so see link. I

Materials:

- Arduino UNO R3/ Arduino Leonardo -----[\$17 @Amazon, clone = \$12]
- Pololu Dual VNH5019 Motor Shield (2x30A) -----[\$39 on Christmas/ reg=\$49]
- 2x 500-1200 rpm 37D Metal Gearbox (19:1) -----[\$48, DX version = \$27]
- JY-MCU Bluetooth Module (10-15m Range) -----[\$8.20]
- Ground/ Line Digital Sensors (Schmitt Trigger) -----[\$4.60]
- 3x Sharp Proximity Sensors (Not Included in \$90) ---[\$30 Optional]
- 2x Recycled Tamiya RC Wheels (Free - Inventory) ---[Recycled Free!]
- DIY/ Custom Gearbox, Aluminum Bracket -----[Recycled Free! <Alternative Link \$7]
- Recycled 4cell 1.3Ah LiPo (From Bloated Turning) --[Recycled Free! <Alternative Link]
- 19x16 Acrylic (Thickness 50mm) -----[\$5 - Local Hardware Store]
- Super Glue Bottle (Gorilla 10ml) -----[\$5 - Free If You have one]

Tools:

- Leatherman
- Dremel Rotary Tool
- Jigsaw (Blade for Acrylic)

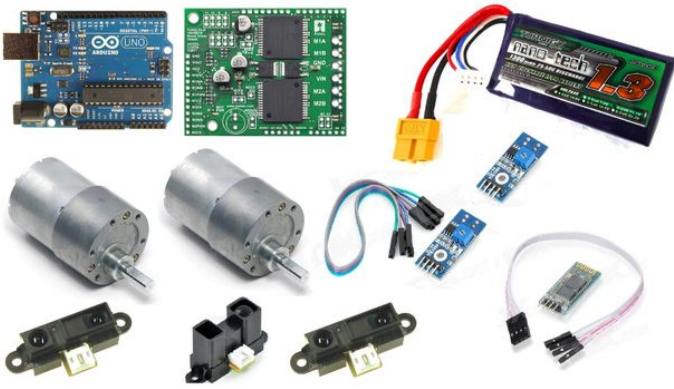

Step 2: Choosing Your Metal Gearbox

In my opinion, Pololu is the best place to buy high quality metal gearboxes, they are expensive though. My second choice is DX.com , they sell a lot of cheap ones, but they only sell those "high-torque: low-speed".

Links:

- Pololu List: Metal Gearboxes
- DealExtreme List: Metal Gearboxes
- I have the pololu gearbox 37D (19:1, 500RPM)

Ratio Dictionary:

- **Torque** = Provides a high output power. (ex. A truck needs high torque when climbing up a hill with a heavy load "1st gear")
- **Speed** = The RPM rating, swiftness of an object (ex. On a flat surface, race cars need a lot of speed to catch up "7th gear")
- When using the same motor setup, high-torque gearboxes have a lower speeds, while high-speed gearboxes have lower torques.



Gear Ratio	No-Load Speed @ 12 V	Stall Torque @ 12 V	Stall Current @ 12 V	www.pololu.com	
				With Encoder	Without Encoder
1:1	11,000 RPM	5 oz-in	5 A	motor_without_gearbox	
19:1	500 RPM	84 oz-in	5 A	37Dx52L mm	37Dx52L mm
29:1	350 RPM	110 oz-in	5 A	37Dx52L mm	37Dx52L mm
50:1	200 RPM	170 oz-in	5 A	37Dx54L mm	37Dx54L mm
67:1	150 RPM	200 oz-in	5 A	37Dx54L mm	37Dx54L mm
100:1	100 RPM	220 oz-in	5 A	37Dx57L mm	37Dx57L mm
131:1	80 RPM	250 oz-in	5 A	37Dx57L mm	37Dx57L mm

Step 3: Choosing Your Motor Driver

I had the Pololu Dual VN5019 (High-Performance 30A Motor driver) for about a year now, it performs really well and doesn't even sweat/ heat-up. The Arduino R3 Motor Shield is also a great choice, but can only support 4A motors. DealExtreme on the other hand sells cloned versions for half the price, I haven't tried them yet but the reviews are good.

My Preferred Choices:

- 1st.) Pololu Dual VN5019 (2x30 Amperes) - \$49 (\$35 Christmas)
- 2nd.) DX Dual VNH Clone (2x30 Amperes) - \$24
- 3rd.) Arduino R3 Motor Shield (2x4 Amperes) - \$25
- 4th.) DX, R3 Motor Shield Clone (2x4 Amperes) - \$13

Arduino R3 Motor Shield \$25

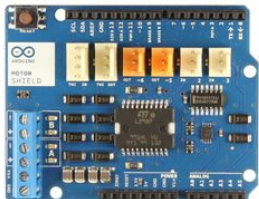

DX R3 Motor Shield Clone \$13

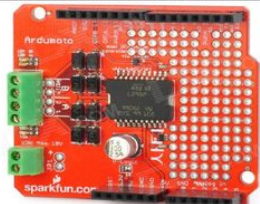

Pololu VN5019 Motor Shield \$49 (\$35 on Dec 25)

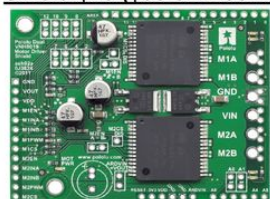

DX VNH Motor Driver Clone \$24 + Free Shipping

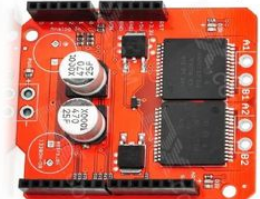

Step 4: Mounting The Motors

Use your Dremel, or Jigsaw to cut a 19x16cm piece of acrylic (thickness 50mm), this will be used for your chassis. I found these cool L-shaped aluminum brackets from the trash, I used it to fabricate my own "Gearbox Mounts". It's free! =D

You can ask for some L-aluminum from a nearby, on ongoing constructions (aluminum scrap inventory).

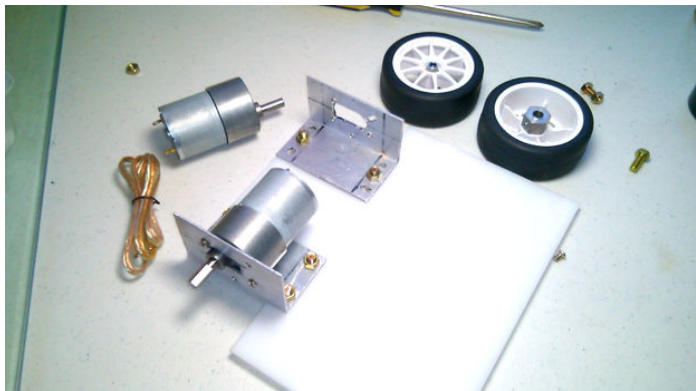

Step 5: Gluing The Side Panels

It took me a lot of sweat to cut these side panels. I did it the hard way, by using a file and hacksaw. In my experience, using rotary tools on acrylic is a big no, since I shattered a lot of them before.

For the wheels, I needed an adapter/ hubs for the Tamiya RC wheels, so I fabricated mine using a lathe machine. If you want the ones, ready made, go to BaneBots.com

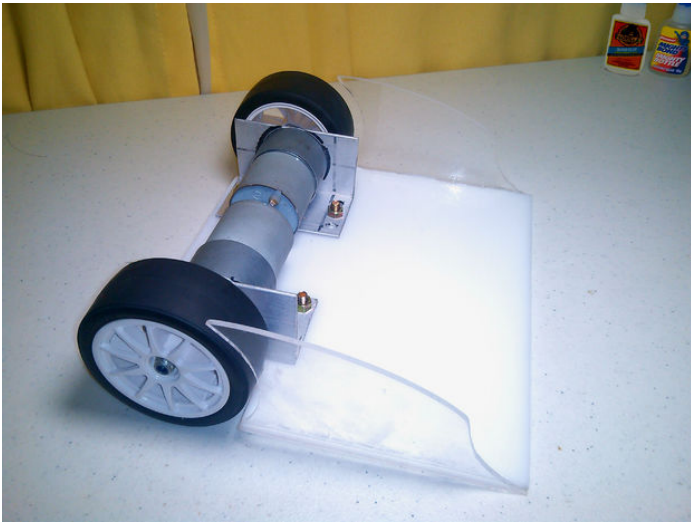

Step 6:

Since this bot was intended to be a sumobot, the scoop/ blade was designed for combat, it must be perfect. Again, rotary tools rotate too fast, therefore you don't have that much control over it. Instead I used the trusty old file to do the job.

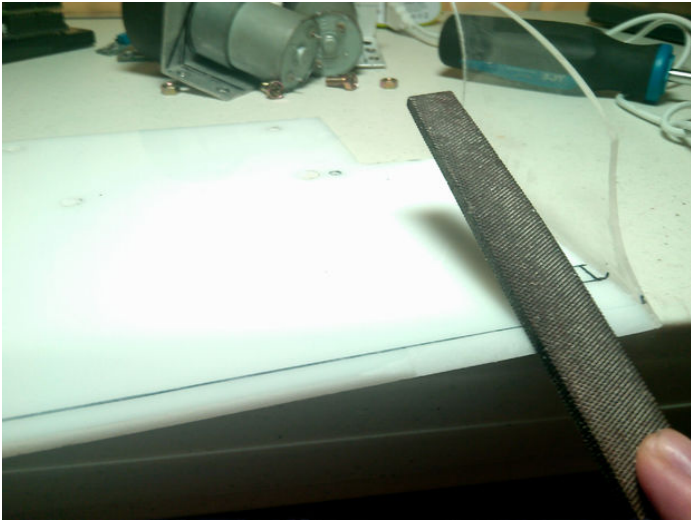

Step 7: Installing The Batteries

The battery's position plays a huge roll on balance. If placed on the back then there's a bigger chance of having a wheelee' effect, this increases traction, but if your batteries are located near the front, traction will decrease while the wheelee effect decreases too.

We all know that Lithium-Polymers bloat, and when they bload they start to become useless (fear of exploding). I debloated them by carefully punching a hole, small enough for the hydrogen gasses to escape, then I patched them.

Warning: Debloating batteries is not advisable, do it at your own risk!

If you want to buy a new one, the best, quality brand I know is Turnigy (4Cell, 1300mAh LiPo) they also feature a 1 year warranty.

- Pic1: My Current Design (CALSONIC)
- Pic2: My Previous Deisgn (FAC3PALM)
- Pic3: My Previous Deisgn (FAC3PALM)

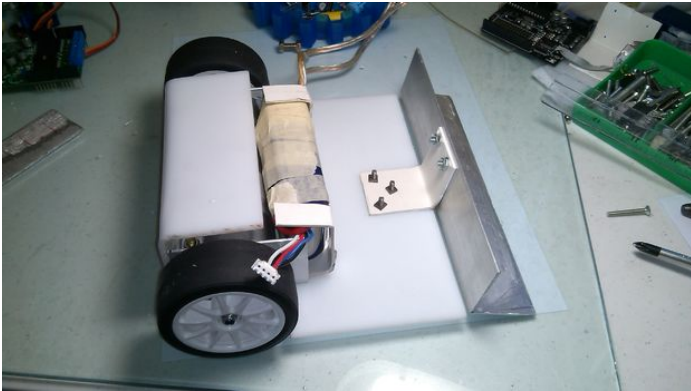
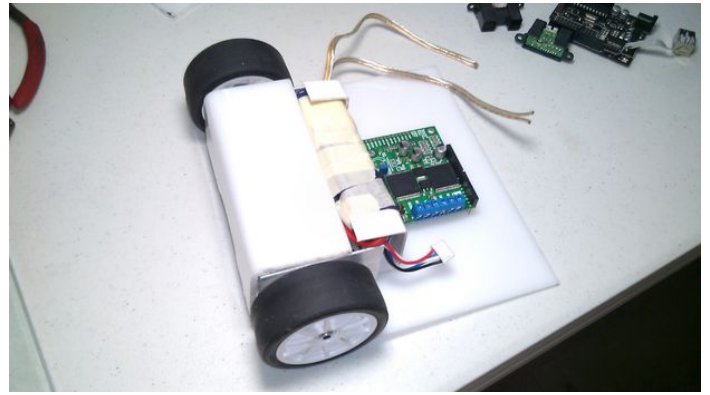
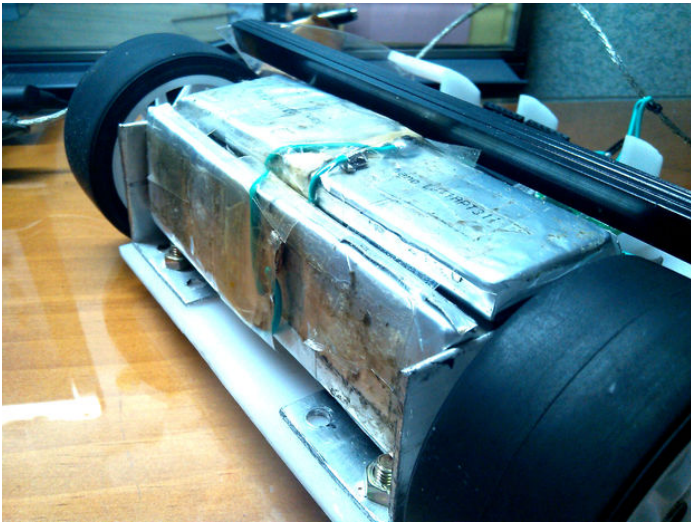

Step 8: Installing The Arduino Shields & Sensors

As we all know, it's easy to assemble the shields. Just snap in the "Motor Driver" above the Arduino UNO. Then wire up your sensors to your board. The Bluetooth connection will be shown in the next step.

I found this cool looking fan from an old PC videocard. I installed it since it make you bot look intimidating.
For the scoop, I hacksawed 4 identical pillars then glued them with super glue and reinforced by clear epoxy.

The sensors are optional, I installed them since the robot is intended to fight in the autonomous division.

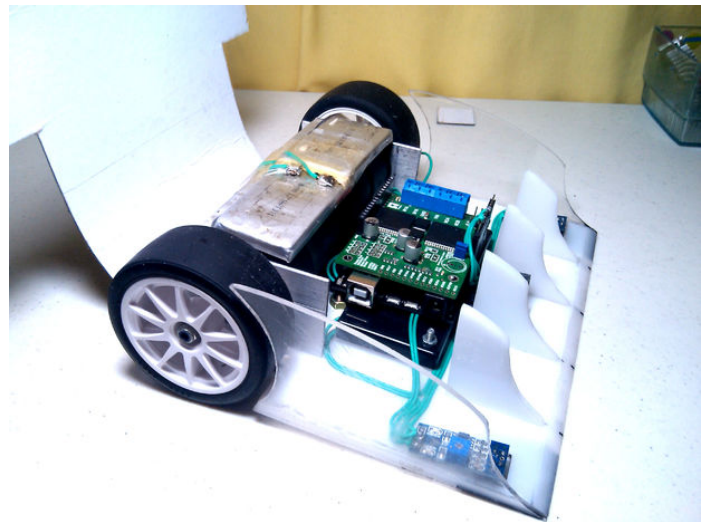
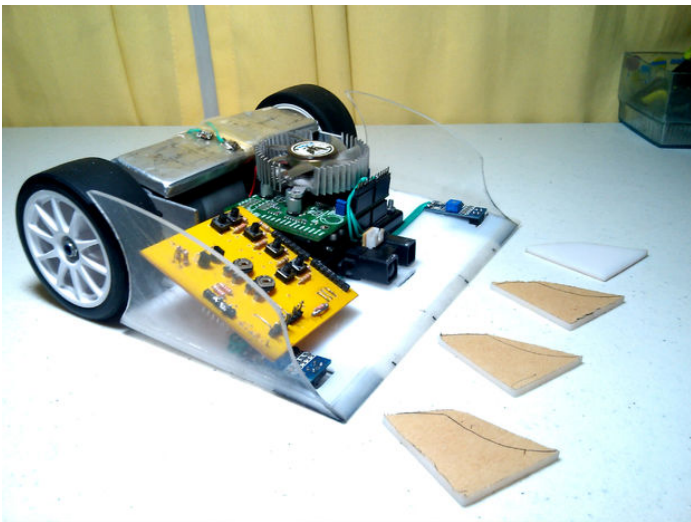

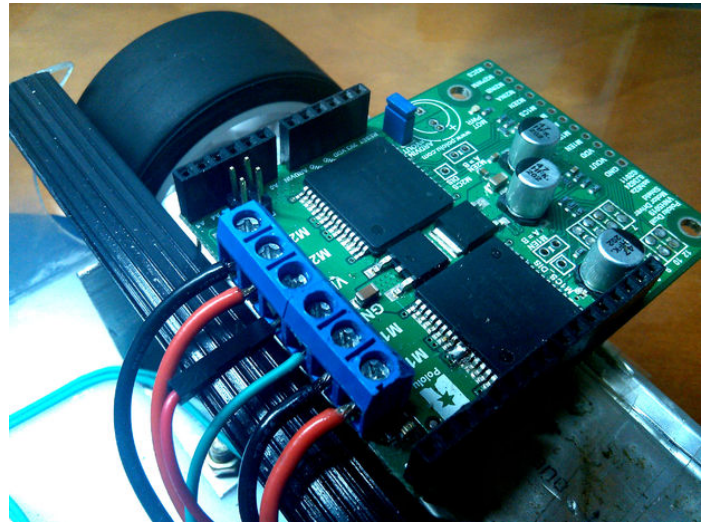
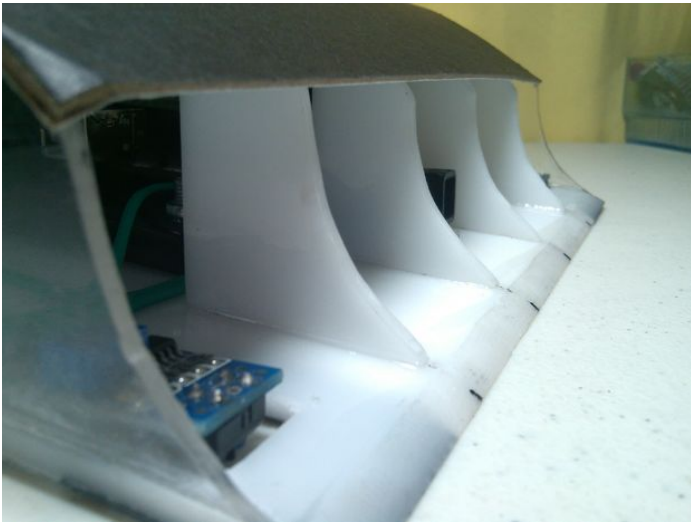

Step 9: Installing The Hood (Takes A Lot of Thinking)

It took me a lot of time to design my hood. Since this robot was intended for combat (@National Competition), it is essential to have a highly accessible hood, in case problems start to show up during the competition. My first hood version used a sheet of 1/8 illustration board. The second one used a bent metal sheet, I used the sliding folder's clip as the mount.

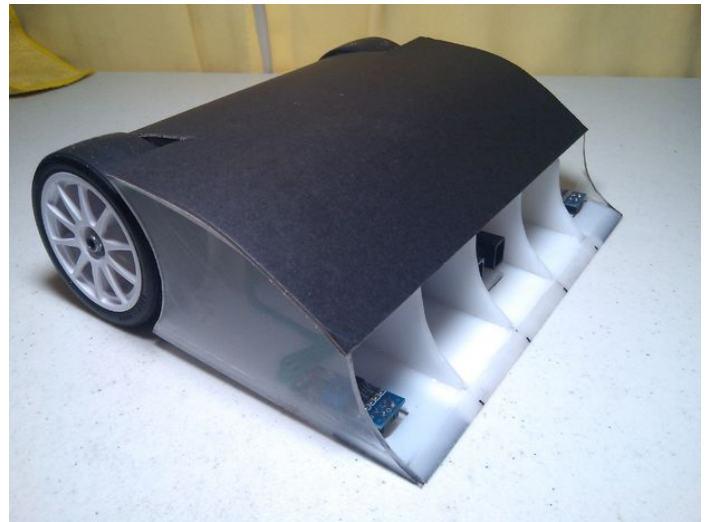
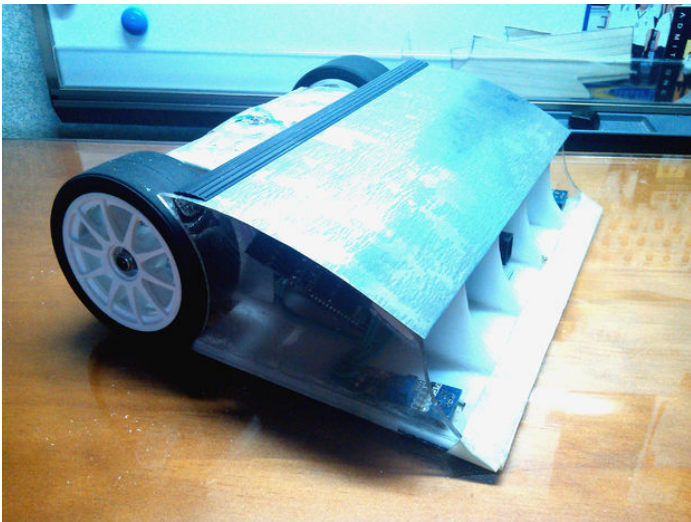

Step 10: Installing & Knowing Your Bluetooth Module

You can buy your Bluetooth Module from DX.com , for \$8, don't worry about the shipping because it's free. There's a graphic diagram below. Now let's get started, first your package should come with a wire (extender), connect your +5v to your duino, then your ground wire. Second the TX from your Bluetooth should go to your Arduino's RX and the RX of your bluetooth to your Arduino's TX.

REMEMBER: Before programming, disconnect your Bluetooth's TX & RX from your Arduino to avoid errors.

How it works: So far, I know that the APP sends letters to your Arduino board via bluetooth. Your Arduino, then decodes these by using statements and condition, which will be discussed on the next page.

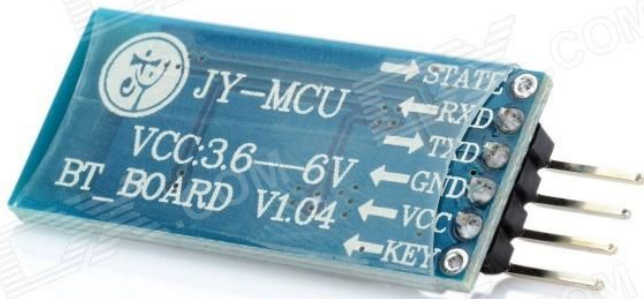
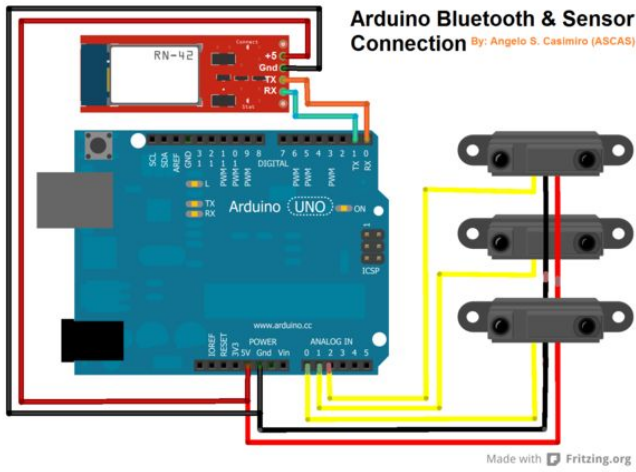

Step 11: The Arduino Codes (C++)

I reconstructed the codes since they were intended for a L298N motor shield. I also changed the executions and added more math, divisional processes, thus making the movements more fluid and dynamic. The toggle switches are disabled, you can enable them by removing the "// (comment sign)".

Attention: The codes only work on the "Pololu Dual VN5019" you'll need to reconstruct the codes if you're using the R3 motor shield.

The App can be downloaded from "play": Arduino Bluetooth RC Car

The original code can be found here: Bluetooth RC Codes

My Codes for my VN5019 Setup: Arduino Bluetooth RC

// Reconstructed By: Angelo Casimiro (ASCAS)

```
#include "DualVN5019MotorShield.h"
DualVN5019MotorShield md;
char dataIn='S';char determinant;char det;int vel = 0; //Bluetooth Stuff
//int power = 4; // Remove This To Enable Tollge Switch #2
int overdrive = 13; //Press Toggle Switch #1, the pin13 LED will light up
```

```
void setup(){
  Serial.begin(9600);md.init();
```

<http://www.instructables.com/id/Android-Controlled-Bluetooth-Sumobot-Ultimate-DIY/>

```

/*pinMode(power , OUTPUT);*/ //toggle switch function
pinMode(overdrive, OUTPUT);
}

void loop(){ det = check(); // You'll need to reconstruct this if you're not using the Pololu Dual VNH5019

while (det == 'F') // F, move forward
{md.setSpeeds(vel,vel);det = check();}

while (det == 'B') // B, move back
{md.setSpeeds(-vel,-vel);det = check();}

while (det == 'L') // L, move wheels left
{md.setSpeeds(vel/4,vel);det = check();}

while (det == 'R') // R, move wheels right
{md.setSpeeds(vel,vel/4);det = check();}

while (det == 'I') // I, turn right forward
{md.setSpeeds(vel,vel/2);det = check();}

while (det == 'J') // J, turn right back
{md.setSpeeds(-vel,-vel/2);det = check();}

while (det == 'G') // G, turn left forward
{md.setSpeeds(vel/2,vel);det = check();}

while (det == 'H') // H, turn left back
{md.setSpeeds(-vel/2,-vel);det = check();}

while (det == 'S') // S, stop
{md.setSpeeds(0,0);det = check();}

//-----Toggle switch code-----//
/* while (det == 'U')
{digitalWrite(power, HIGH);det = check();}
while (det == 'u')
{digitalWrite(power, LOW);det = check();}*/
//-----Mains Power-----//
while (det == 'W')
{digitalWrite(overdrive, HIGH);det = check();}
while (det == 'w')
{digitalWrite(overdrive, LOW);det = check();}
}

int check()
{if (Serial.available() > 0) {dataIn = Serial.read();
if (dataIn == 'F'){determinant = 'F';}
else if (dataIn == 'B'){determinant = 'B';}else if (dataIn == 'L'){determinant = 'L';}
else if (dataIn == 'R'){determinant = 'R';}else if (dataIn == 'I'){determinant = 'I';}
else if (dataIn == 'J'){determinant = 'J';}else if (dataIn == 'G'){determinant = 'G';}
else if (dataIn == 'H'){determinant = 'H';}else if (dataIn == 'S'){determinant = 'S';}
else if (dataIn == '0'){vel = 400;}else if (dataIn == '1'){vel = 380;}
else if (dataIn == '2'){vel = 340;}else if (dataIn == '3'){vel = 320;}
else if (dataIn == '4'){vel = 280;}else if (dataIn == '5'){vel = 240;}
else if (dataIn == '6'){vel = 200;}else if (dataIn == '7'){vel = 160;}
else if (dataIn == '8'){vel = 120;}else if (dataIn == '9'){vel = 80;}
else if (dataIn == 'q'){vel = 40;}else if (dataIn == 'U'){determinant = 'U';}
else if (dataIn == 'u'){determinant = 'u';}else if (dataIn == 'W'){determinant = 'W';}
else if (dataIn == 'w'){determinant = 'w';}}return determinant;}

```

```
File Edit Sketch Tools Help
sketch_sep01a Arduino Bluetooth Codes (CLASONIC 1KG SUMOBOT) $
void loop(){ det = check();

while (det == 'F') // F, move forward
(md.setSpeeds(vel,vel);det = check();)

while (det == 'B') // B, move back
(md.setSpeeds(-vel,-vel);det = check();)

while (det == 'L') // L, move wheels left
(md.setSpeeds(vel/4,vel);det = check();)

while (det == 'R') // R, move wheels right
(md.setSpeeds(vel,vel/4);det = check();)

while (det == 'I') // I, turn right forward
(md.setSpeeds(vel,vel/2);det = check();)

while (det == 'J') // J, turn right back
(md.setSpeeds(-vel,-vel/2);det = check();)

while (det == 'G') // G, turn left forward
(md.setSpeeds(vel/2,vel);det = check();)

while (det == 'H') // H, turn left back
(md.setSpeeds(-vel/2,-vel);det = check();)

while (det == 'S') // S, stop
```

One file added to the sketch.

45 Gizduino miniUSB w/ ATmega328 on COM14

File Downloads



Arduino Bluetooth Codes (CLASONIC 1KG SUMOBOT).rar (1 KB)

[NOTE: When saving, if you see .tmp as the file ext, rename it to 'Arduino Bluetooth Codes (CLASONIC 1KG SUMOBOT).rar']

Step 12: Your'e Done! Enjoy Your, Heavy Combat Sumobot!

You're done! Cheers! You've finished your Android Controlled Sumobot. Cheers! =D

Don't forget to vote and leave a comment. =D

Watch that video again :D

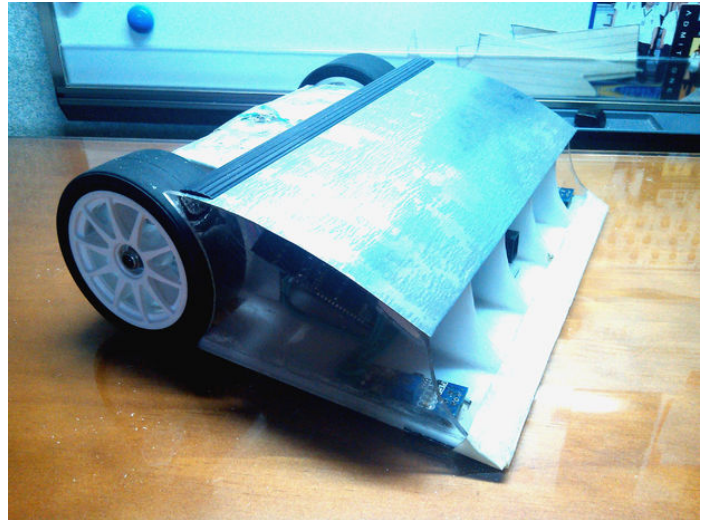

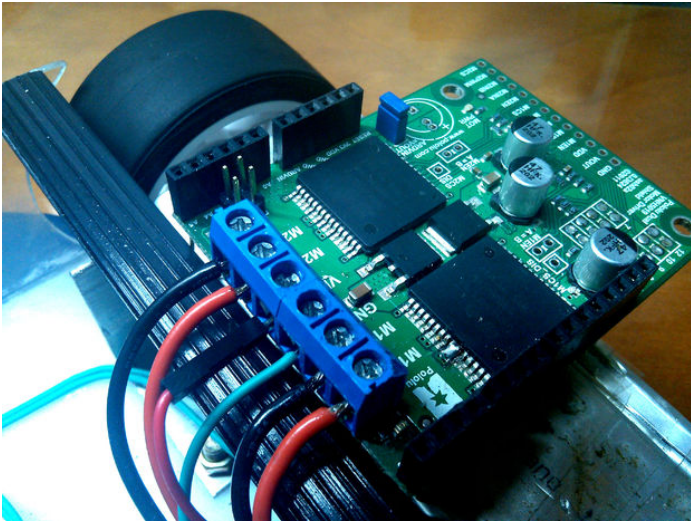
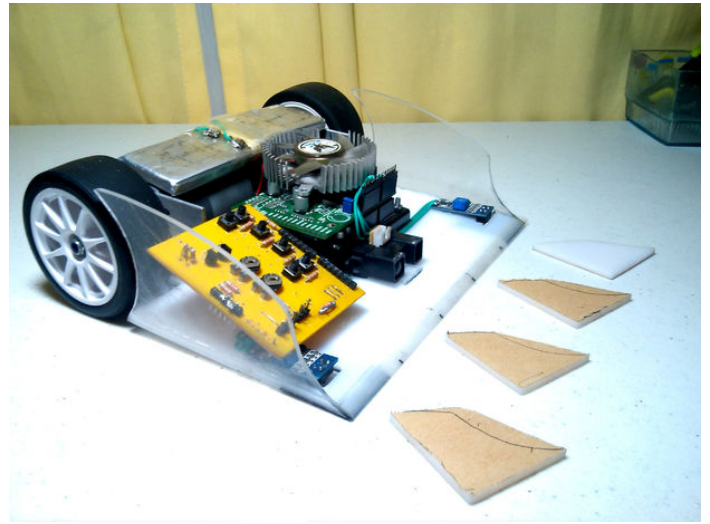
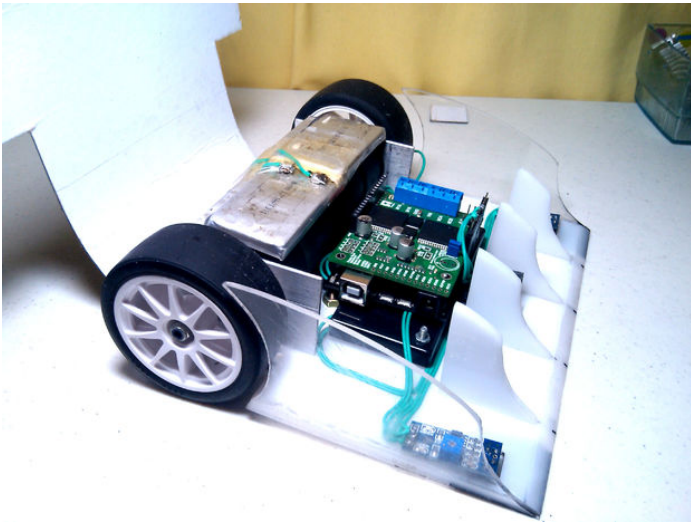

Related Instructables



CxemCAR 1 - Android Control RC Car over Bluetooth by tolik777



Super Nintendo on Android with original controller (video) by bsoares



Simple RC car for beginners (Android control over Bluetooth) by tolik777



My Mini Sumobot (500g Prototype) (Photos) by ASCAS



Cheap 2-Way Bluetooth Connection Between Arduino and PC by techbitar



Reverse Engineering =Uzzors2k= Bluecar Android App. Amarino Stuff Too. by robwasab

