

Operation Instruction

Model:A8

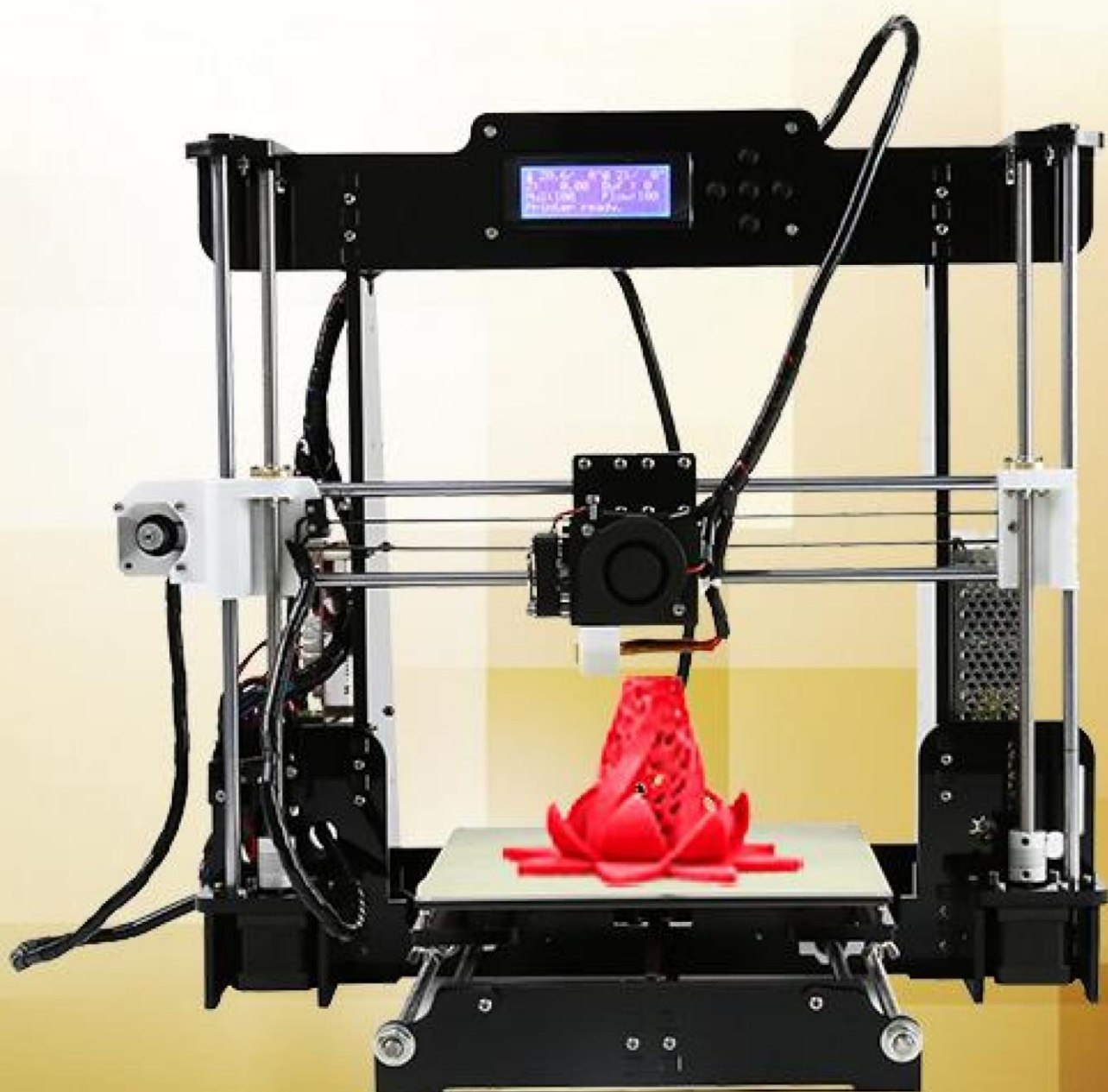

Contents

INTRODUCTION	2
A. Security Considerations	3
B. Product Details	4
1.Specifications	4
2.Machine parts	4
3.Extruder drawing	5
4.Tool List	6
C. Cura Software	9
1.Installation of Cura14.07	9
1.1 File location in the TF card	9
2. Cura Setting	18
2.1 Clear platform	18
2.3 Layer height settings	23
D. Printing Operation	46
1. Introduction of Display	46
2. Install Filament	56
2.1 Set Preheat Mode	56
2.2 Filament Installation	57
2.3 Pull out filament	59
3. Platform Adjustment	60
4. Printing	62
E. FAQ and Solution	65
1. Z Axis Ajustment	65

2. Nozzle blocking	67
3. FAQ	69
F. Maintenance	70
G. Maintenance policy	71

INTRODUCTION

A8 FDM 3D printer can print CAD 3D printer model to real . A8 uses Acrylic to build its frame while it uses linear bearings , belts and threaded rods to build X , Y , Z axis .

It enables A8 to print steadily with no vibration .

Note:

1. All statement included in this Instructions have been checked carefully , if any typographical errors or misunderstanding , we have the final interpretation .
2. No noification if any update .

A. Security Considerations

To avoid danger when using 3D printer , please pay attention to precautions below .

⊗ Danger

During Operation , the maximum temepature of nozzle can be 260 °C while hotbed can be 100 °C . For your safety , during printing or cooling down , do not touch the nozzle , hotbed and models under printing . Power works at 110V/220V 50HZ AC and supply ground needed . Do not use other power supply , or it may cause components damage , fire or electric shock . And we take no responsibility for this .

⚠ Warning

We suggest wearing protective goggles when removing auxiliary support materials .
 Some filaments will emit slight irritant gases , so we suggest to use 3D printer in a ventilated environment .

Note: ABS filament will emit a bit toxic gases when it melts .

B. Product Details

1.Specifications

Model: A8	Nozzle diameter: 0.4mm
Layer thickness: 0.1-0.3mm	Machine size: 500*400*450mm
Printing speed: 10-120mm/s	Machine weight: 7.5KG
X Y axis position accuracy: 0.012m	Packing size: 510*345*215mm
Z axis position accuracy: 0.004m	Gross weight: 9.2KG
Printing material: ABS,PLA	Build size: 220*220*240mm
Material tendency: PLA	LCD screen: Yes

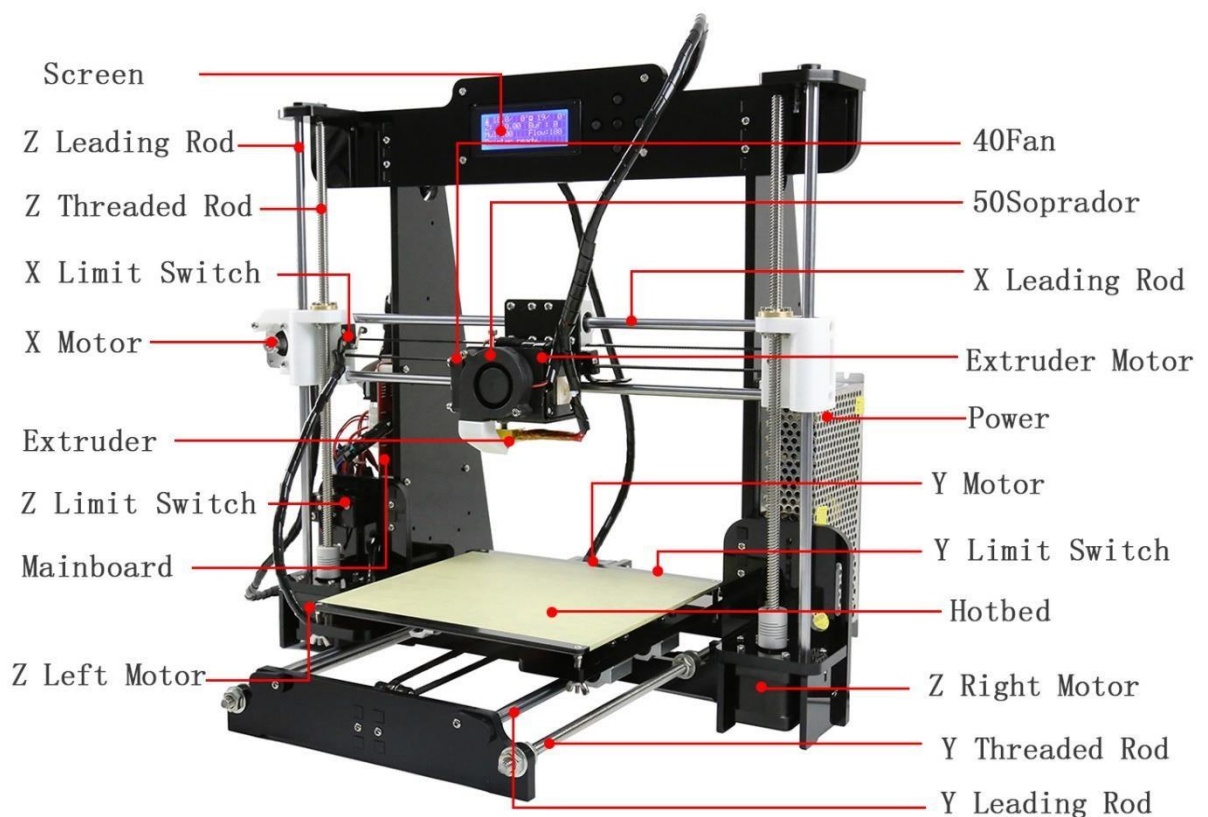

Filament diameter : 1.75mm	Offline printing: TF CARD
Software language: Multi-Language	File format: STL、G-Code、OBJ
Function of support: automatically	OS: windows(linux、 mac)
Software: Cura	Working condition: 10-30°C, Humidity 20-50%

2.Machine parts

3.Extruder drawing

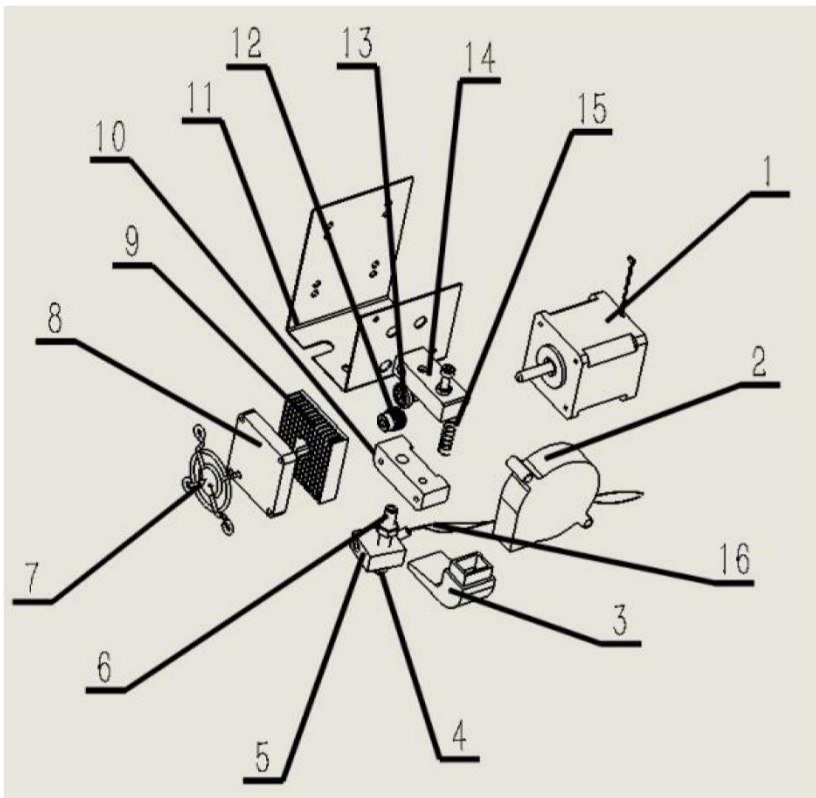



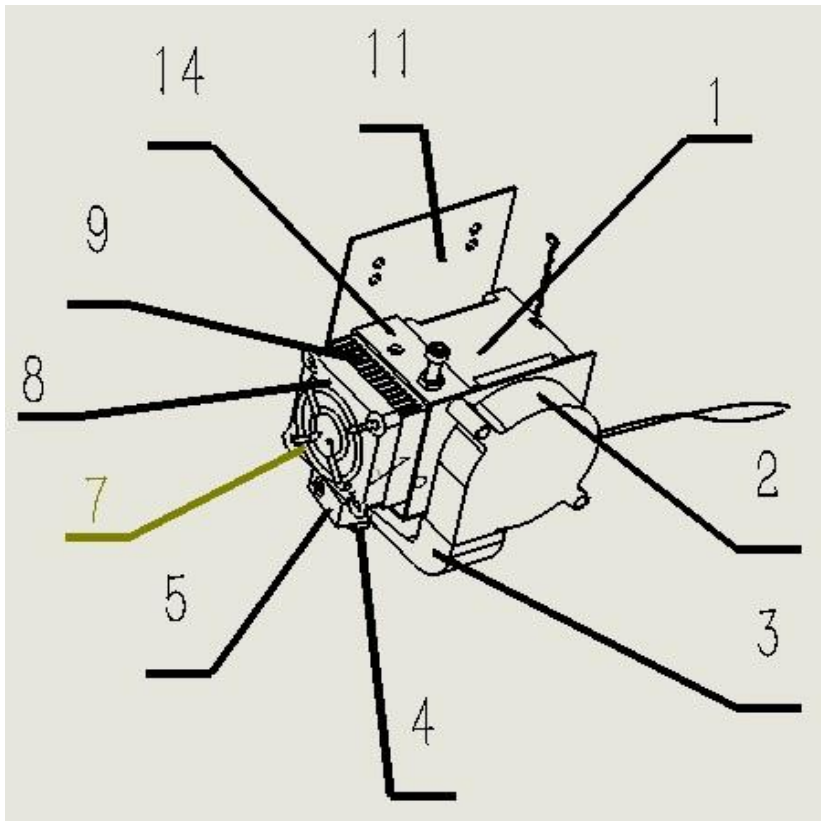











No.	Part Name	Quantity
1	Extruder Motor	1
2	Blower	1
3	Wind Mouth	1
4	Nozzle (0.4mm)	1
5	Heating Block	1
6	Throat	1
7	Fan Cover	1
8	Fan	1
9	Heat Sink	1
10	Extruder Seat	1
11	Bend Parts	1
12	Brass Wheel	1
13	U-Bearing	1
14	Briquetting	1
15	Spring	1
16	Heating Pipe	1





















4.Tool List











3D Printer A8 assembly parts list





Item	Material number	Picture	Name	QTY	Item	Material number	Picture	Name	QTY
1-1	1700100001		Hot bed fixed aluminum plate	1	2-1	1700200004		Mainboard	1
1-2	1700200001		220mm*220mm*3mm Hot bed	1	2-2	1700300005		Left Z axis nut support	1
1-3	1101900001		Plastic nippers	1	2-3	1700300006		Right Z axis nut support	1
1-4			1.5M Power line	1	2-4	1300300001		Wind mouth	1
1-5	1101900008		5mm*160mm Screwdriver	1	2-5	1700300001		1.7M Belt	1
1-6	1700200002		Four parts below in this bag	1	2-6	1202200007		1.5M wire	1

Item	Material number	Picture	Name	QTY	Item	Material number	Picture	Name	QTY
1-6-1	1700200003		40*10 Fan	1	2-7	1700200005		5015 Air blower	1
1-6-2	1101200002		40*11 Cooling fin	1	2-8	1700300002		Y axis belt bearing support	1
1-6-3	1101700001		Fan cover	1	2-9	1700300003		Five parts below in this bag	1
1-6-4	1700100003		M3*45 Screw 2pcs M3 Spacer 8pcs	1	2-9-1	1300100009		Z axis Limit switch fixed plate	2
1-7	1700100004		Screw bag include below screws	1	2-9-2	1300100004		Y axis motor support	1
1-7-1	1700100005		M3*18 screw 50pcs	1	2-9-3	1300100007		Y axis Limit switch fixed plate	1
1-7-2	1700100006		M3 Nut 60pcs	1	2-9-4	1300100005		Y axis belt fixation clamp	2

Item	Picture	Name	QTY	Check	Item	Picture	Name	QTY	Check
1-7-3		M8 Nut 16pcs M8 Spacer 12pcs	1		2-9-5		Guide rod back up plate	6	
1-7-4		M4*8 screw 28pcs M4*14 screw 6pcs	1		2-10		Side support plate	2	
1-7-5		M3*30 screw 14pcs	1		2-11		Filament support plate	2	
1-7-6		M3*12 screw 15pcs	1		2-12		Filament support plate connecting plate	2	
1-7-7		M2*12 screw 4pcs wing nut 4pcs Spring 4pcs	1		2-13		Screen baffle plate	1	
1-7-8		M3*20 screw 4pcs M2.3*10screw 2pcs	1		2-14		Z axis motor support Plate	4	
1-8		Three parts below in this bag	1		2-15		8GB TF card and card reader	1	

Item	Material number	Picture	Name	QTY	Item	Material number	Picture	Name	QTY
1-8-1	1202100006		Wire 65CM	1	3-1	1300100017		Bottom support plate	1
1-8-2	1700200013 1700200014 1700200014		Z Limit switch A 20CM X Limit switch B 50CM Y Limit switch C 50CM	3	3-2	1300100016		Top support plate	1
1-8-3	1300400003 1300400004		Pillar washer M3*7 4pcs Pillar washer M3*15 4pcs	8	3-3	1300100011		Back plate	1
1-9	1700100013		Three parts below in this bag	1	3-4	1300100015		Front plate	1
1-9-1	1101900010		3mm*130mm Screwdriver	1	3-5	1700300024		Support plate lock plate	2
1-9-2	1101900004 1101900006 1101900005 1101900007		Hex wrench M1.5 Hex wrench M2 Hex wrench M2.5 Hex wrench M3	4	3-6	1300100019		Z axis motor fixed plate	2
1-9-3	1101900002		Open spanner	1	3-7	1300100003		Y axis motor fixed plate	1

Item	Picture	Name	QTY	Check	Item	Picture	Name	QTY	Check
1-10		Four parts below in this bag	1		3-8		Extruder	1	
1-10-1		4.5M Winding pipe	1		3-9		X axis motor	1	
1-10-2		Belting	10		3-10		Y axis motor	1	
1-10-3		R clip	3		3-11		Z axis motor	2	
1-10-4		Locating piece	2		3-12		Linear bearing	7	

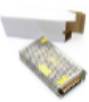
Item	Material number	Picture	Name	QTY	Item	Material number	Picture	Name	QTY
1-11	1700200011		LCD 2004 screen	1	3-13	1700100014		Guide rod 436mm 2pcs Guide rod 380mm 4pcs	6
1-12	1202100031		X Motor line 40CM Y Motor line 40CM Left Z Motor line 40CM Right Z Motor line 90CM Extruder Motor line 90CM	5	3-14	1700100015		T type lead screw M8*345mm 2pcs Threaded rod M8*400mm 2pcs Threaded rod M8*150mm 1pcs	5
1-13	1700200027		Heat bed line 90CM	1	3-15	1200100002		Power Supply	1

C. Cura Software

1.Installation of Cura14.07 a:

Where can I find the software?

- 1) TF card with shipment; 2) download from Internet; b:

Installation process

- 1) From TF card with shipment



Insert TF card and open the file **1.1**

File location in the TF card

1) Insert TF card , open the file

名称 ^	修改日期	类型	大小
 Installation Instruction	2016/7/7 星期四 ...	文件夹	
 Print Model STL	2016/6/22 星期三 ...	文件夹	
 Software	2016/7/7 星期四 ...	文件夹	
 Test file GCODE	2016/6/22 星期三 ...	文件夹	
 Tool List&other pictures	2016/7/7 星期四 ...	文件夹	

名称 ^	修改日期	类型	大小
 CH340G Drive	2016/7/7 星期四 ...	文件夹	
 Cura 14.07	2016/7/7 星期四 ...	文件夹	
 RepetierHost_1_0_5	2016/7/7 星期四 ...	文件夹	

名称 ^	修改日期	类型	大小
 Cura download link.txt	2016/7/1 星期五 ...	文本文档	1 KB
 Cura_14.07.exe	2015/8/11 星期二 ...	应用程序	18,377 KB

2) Download from Internet

Official Website: <https://ultimaker.com/en/cura-software/list>

Choose corresponding software to download

WINDOWS

Version: 2.1.2 32 bit	Release date: 6/7/16
Version: 2.1.2 64 bit	Release date: 6/7/16
Version: 15.04.6	Release date: 6/7/16
Version: 15.04.5	Release date: 3/17/16
Version: 15.04.4	Release date: 1/5/16
Version: 15.04.03	Release date: 11/4/15
Version: 15.04.2	Release date: 7/28/15
Version: 15.04	Release date: 4/15/15
Version: 15.02.1	Release date: 2/19/15
Version: 15.01	Release date: 1/30/15
Version: 14.12	Release date: 12/15/14
Version: 14.09	Release date: 9/19/14
Version: 14.07	Release date: 7/3/14
Version: 14.06	Release date: 6/16/14
Version: 14.03	Release date: 3/17/14
Version: 14.01	Release date: 1/10/14
Version: 13.12	Release date: 12/23/13
Version: 13.11	Release date: 11/22/13
Version: 13.10	Release date: 10/18/13
Version: 13.06.4	Release date: 6/26/13
Version: 13.04	Release date: 4/26/13
Version: 13.03	Release date: 3/8/13
Version: 12.12	Release date: 12/24/12
Version: 12.11	Release date: 11/12/12
Version: 12.10	Release date: 11/8/12

b. Software Installation Process

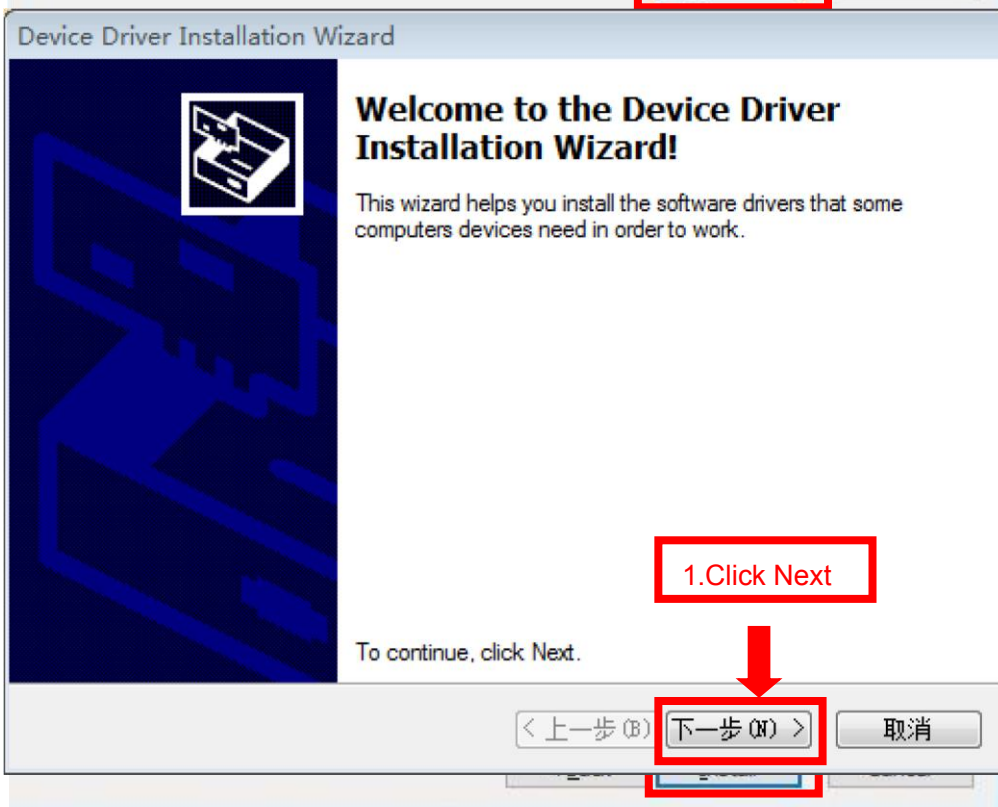
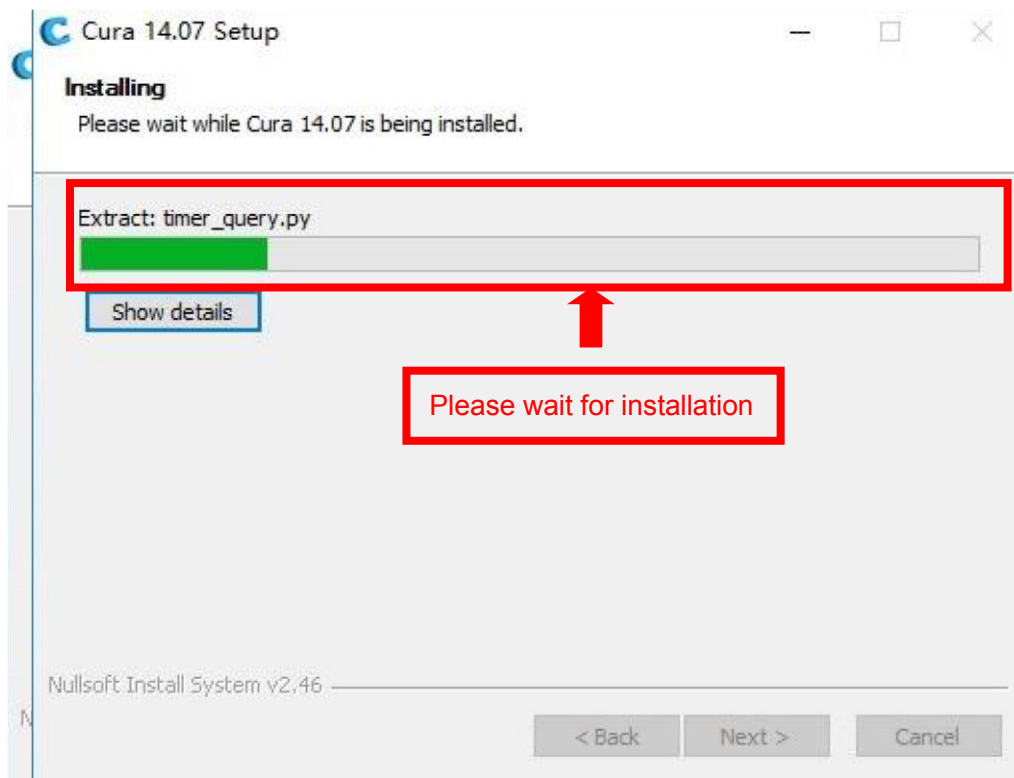

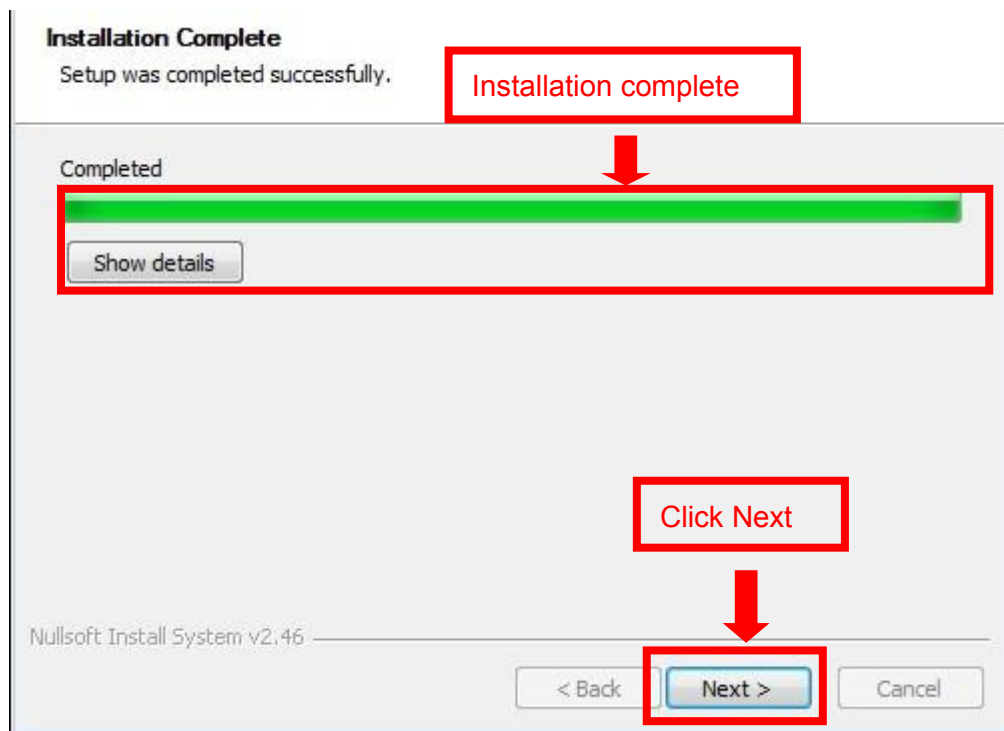
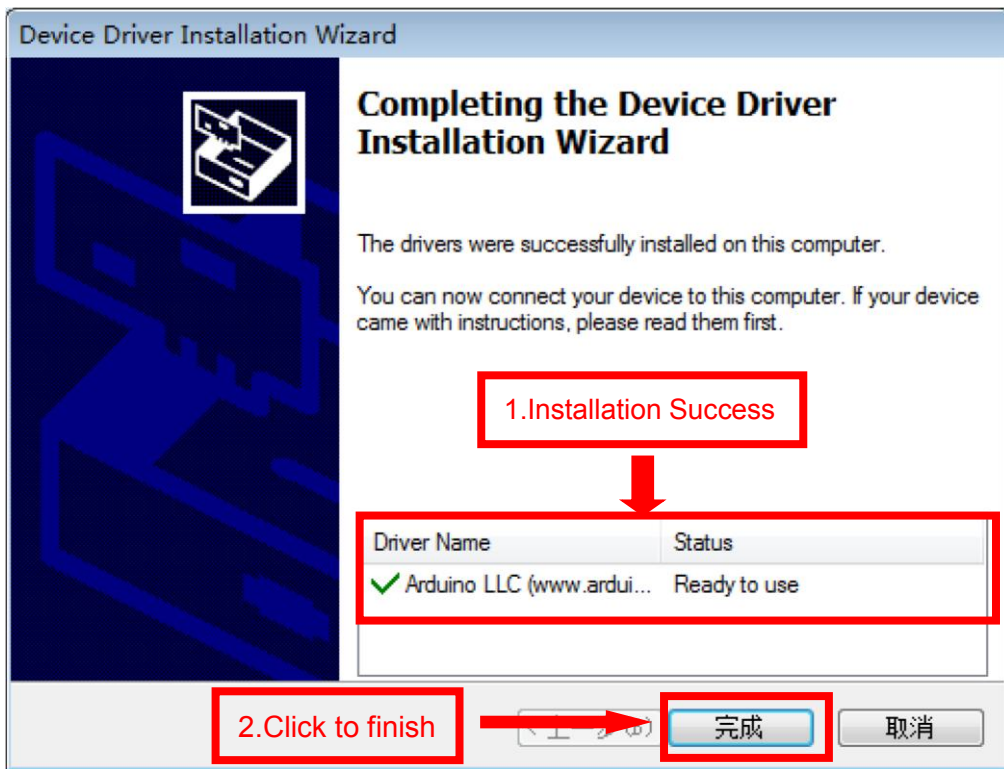

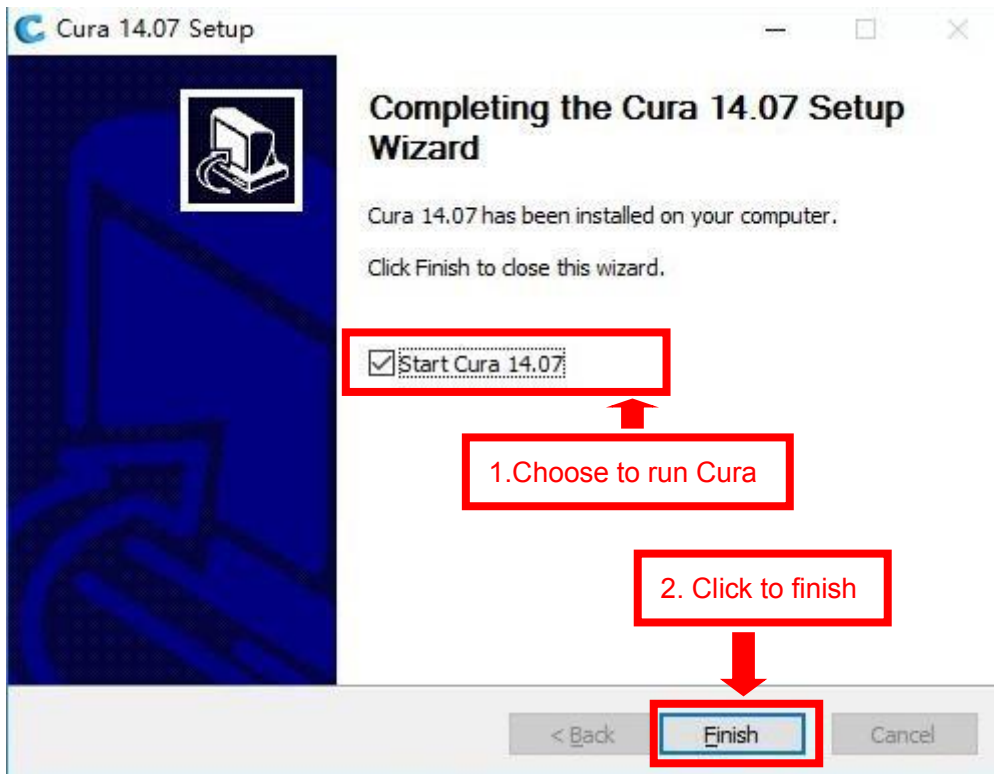

Configuration Wizard

Custom RepRap information

RepRap machines can be vastly different, so here you can set your own settings.
Be sure to review the default profile before running it on your machine.
If you like a default profile for your machine added, then make an issue on github.

You will have to manually install Marlin or Sprinter firmware

Machine name:

Machine width (mm):

Machine depth (mm):

Machine height (mm):

Nozzle size (mm):

Heated bed:

Bed center is 0,0,0 (RoStock):

< Back **Finish** Cancel

This is A8 parameter

You can customize name here.

**We default these data .
You can fill in according to
actual condition**

Choose this option

DO NOT choose this option !!!

1.Click to finish

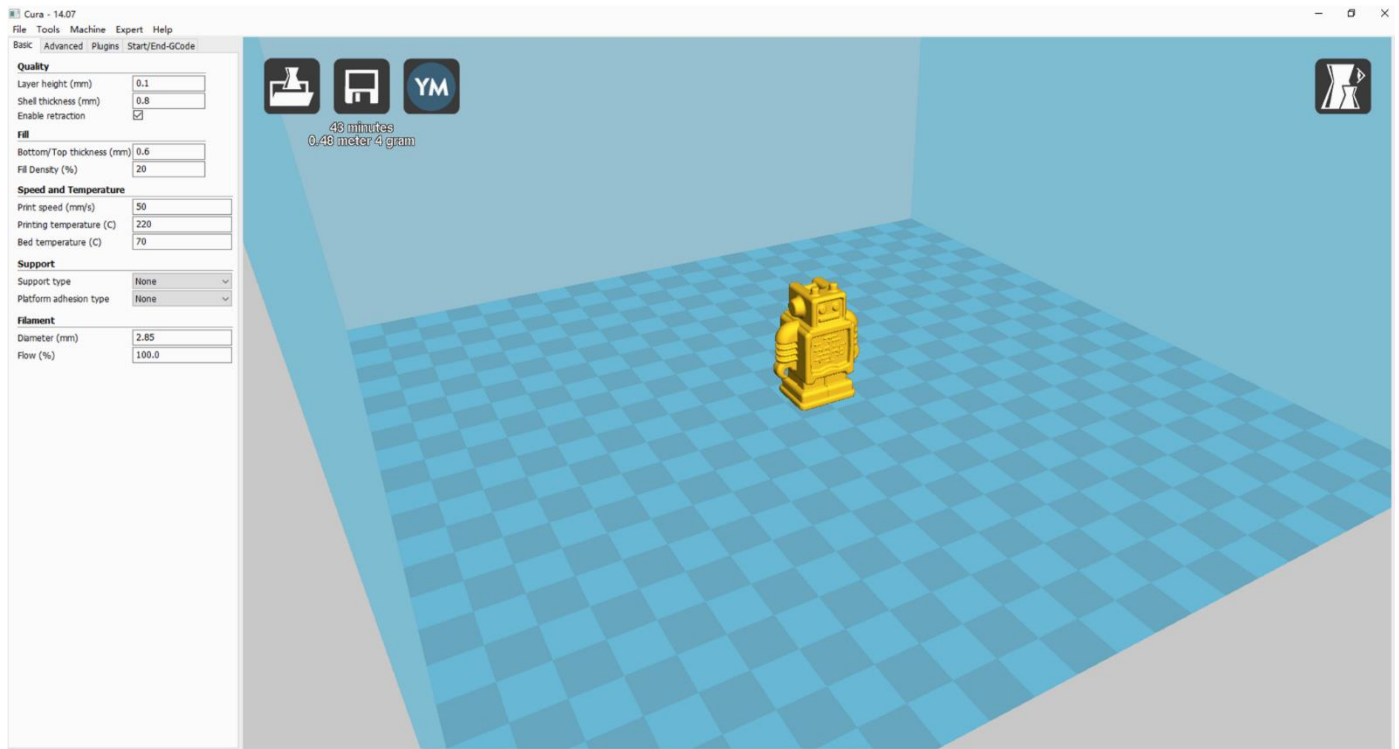

Now you have finished the installation. Next , enter Cura .

2. Cura Setting

2.1 Clear platform

Delete the dog. Two ways for you :

1.Move mouse to dog ,right click, click “delete object”.

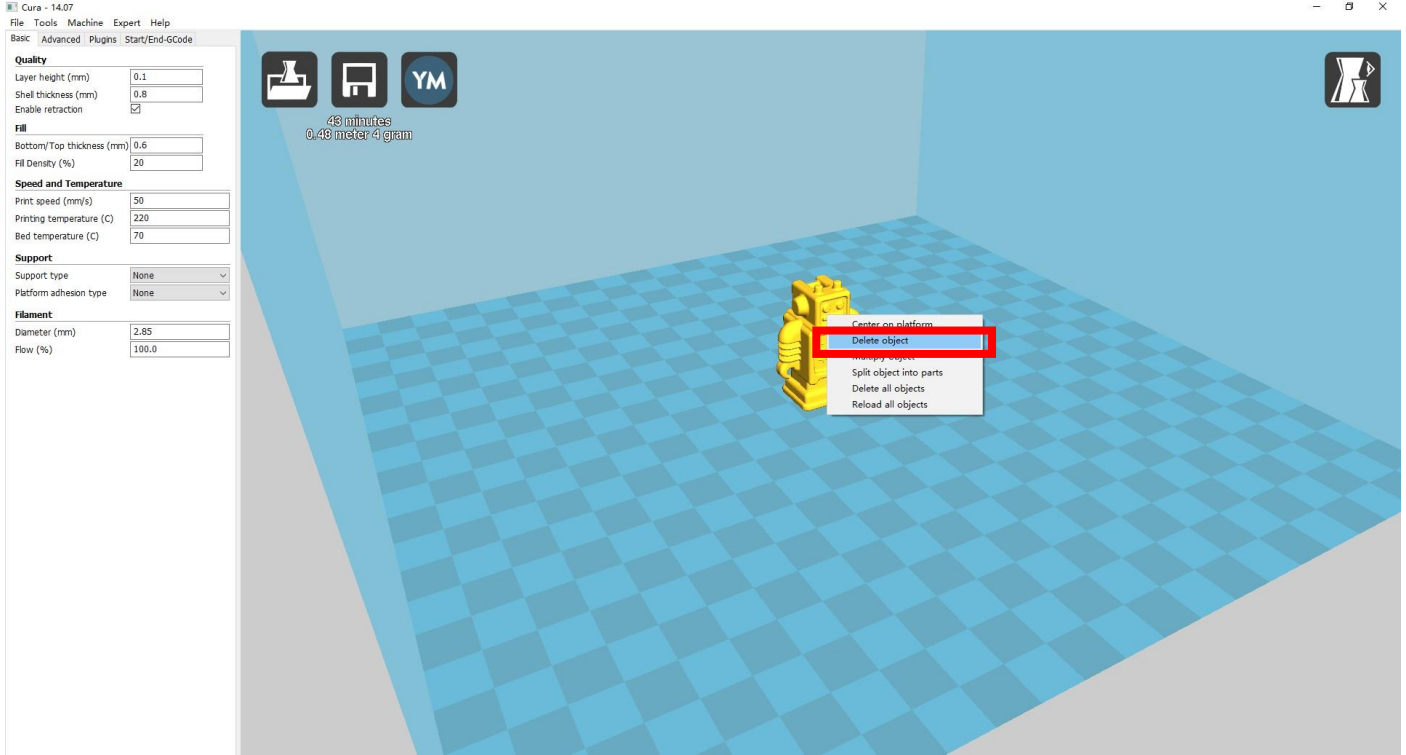

2. Left click "File", choose "Clear platform".

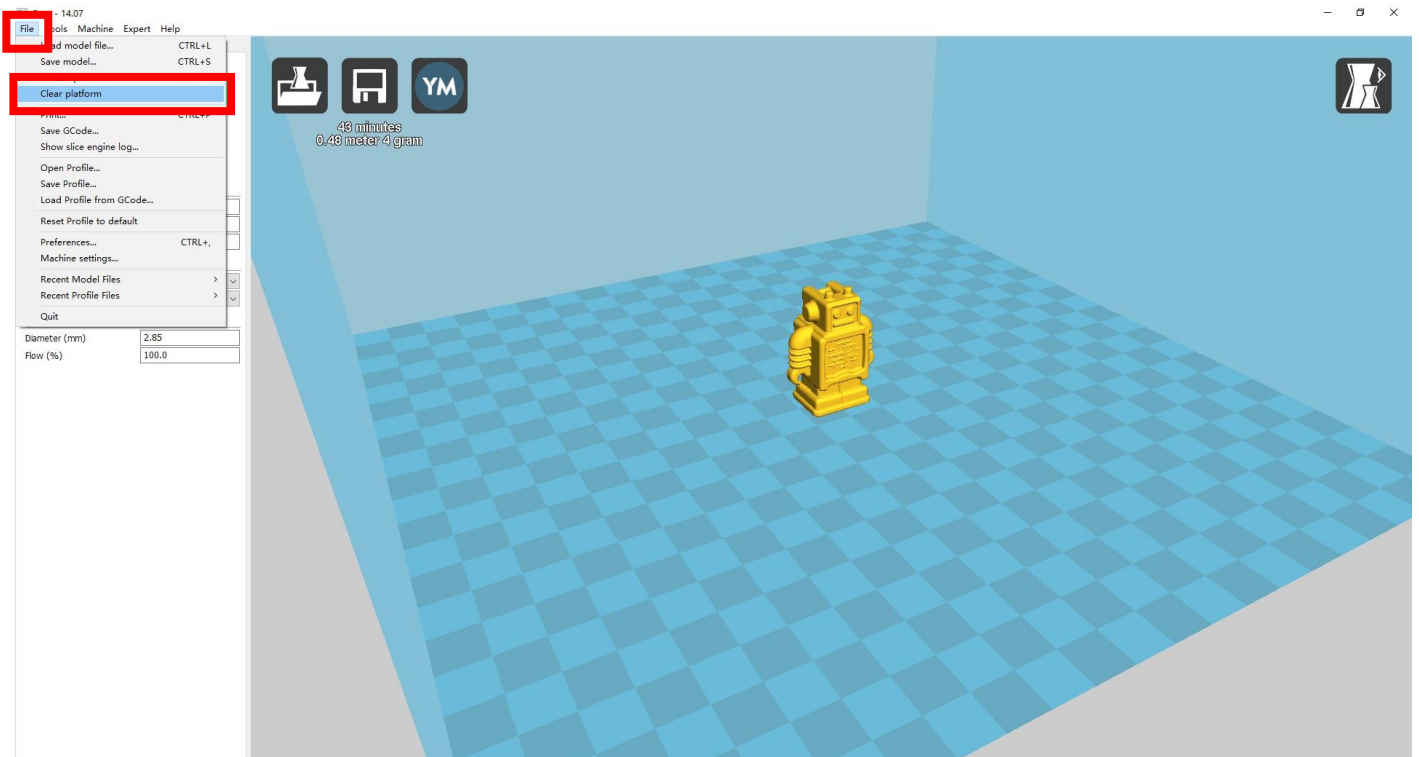

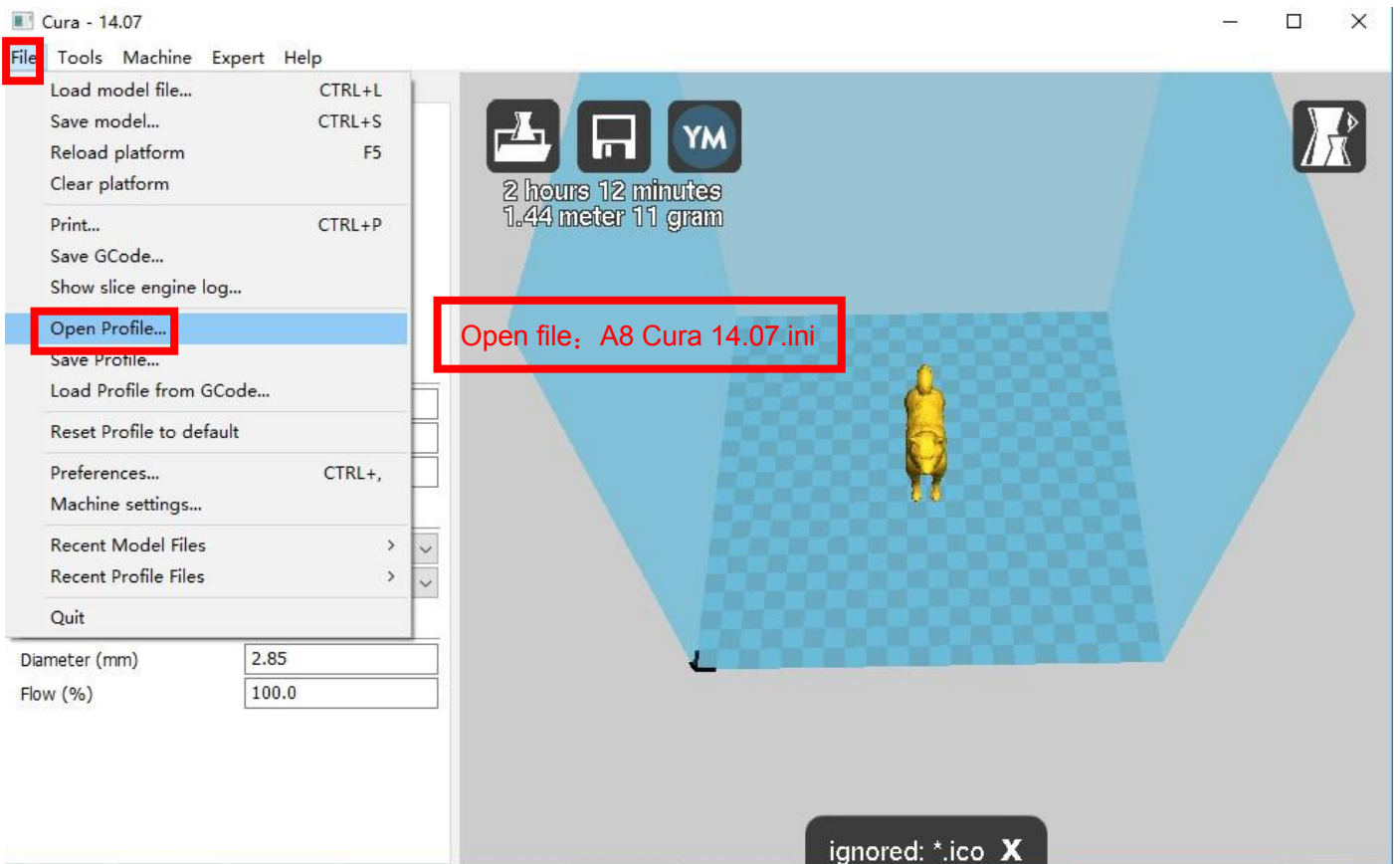
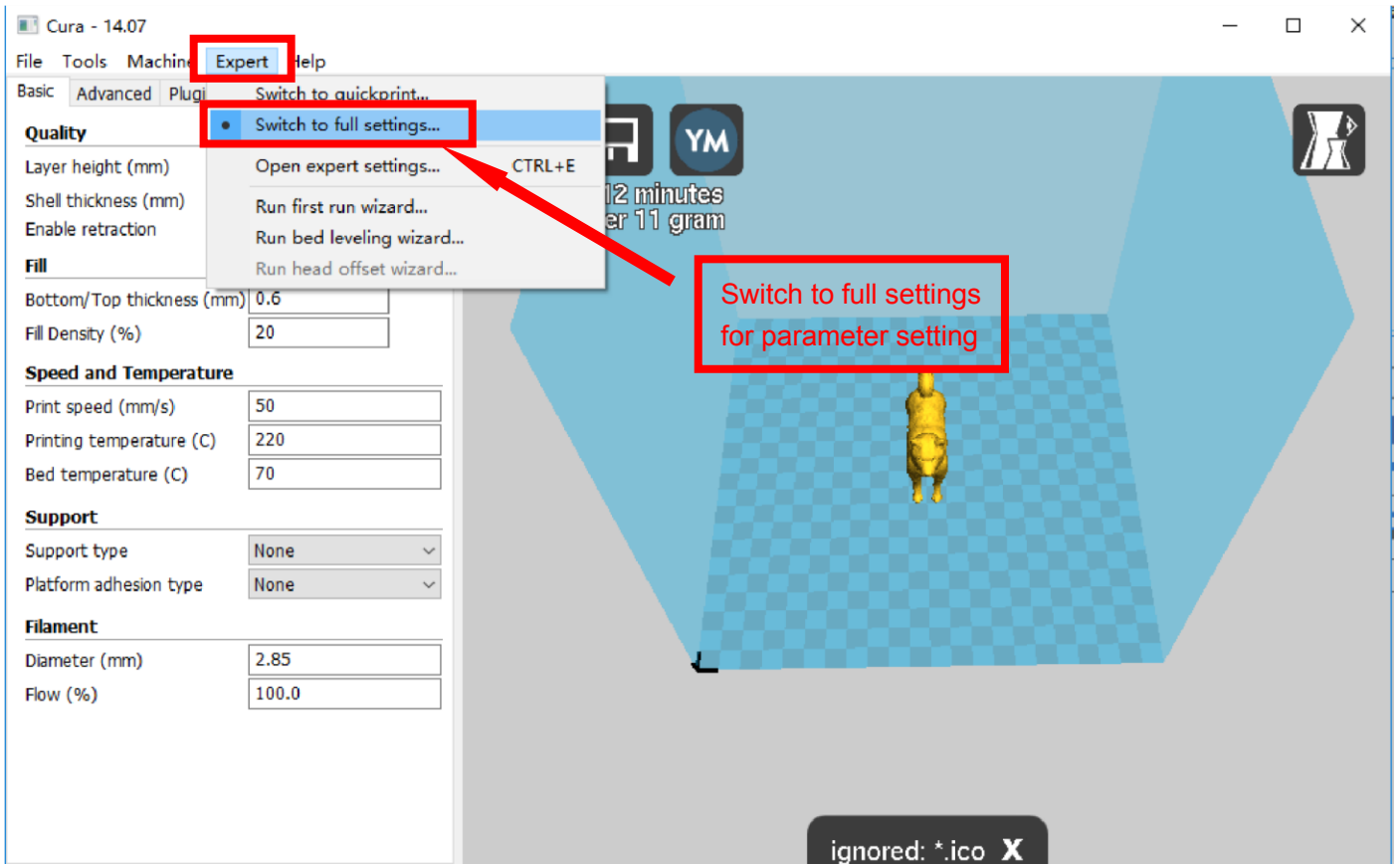

Position of configuration file: Computer/TF card)/ configuration file for cura-14.07

(suggestion :keep this file copy to your computer)

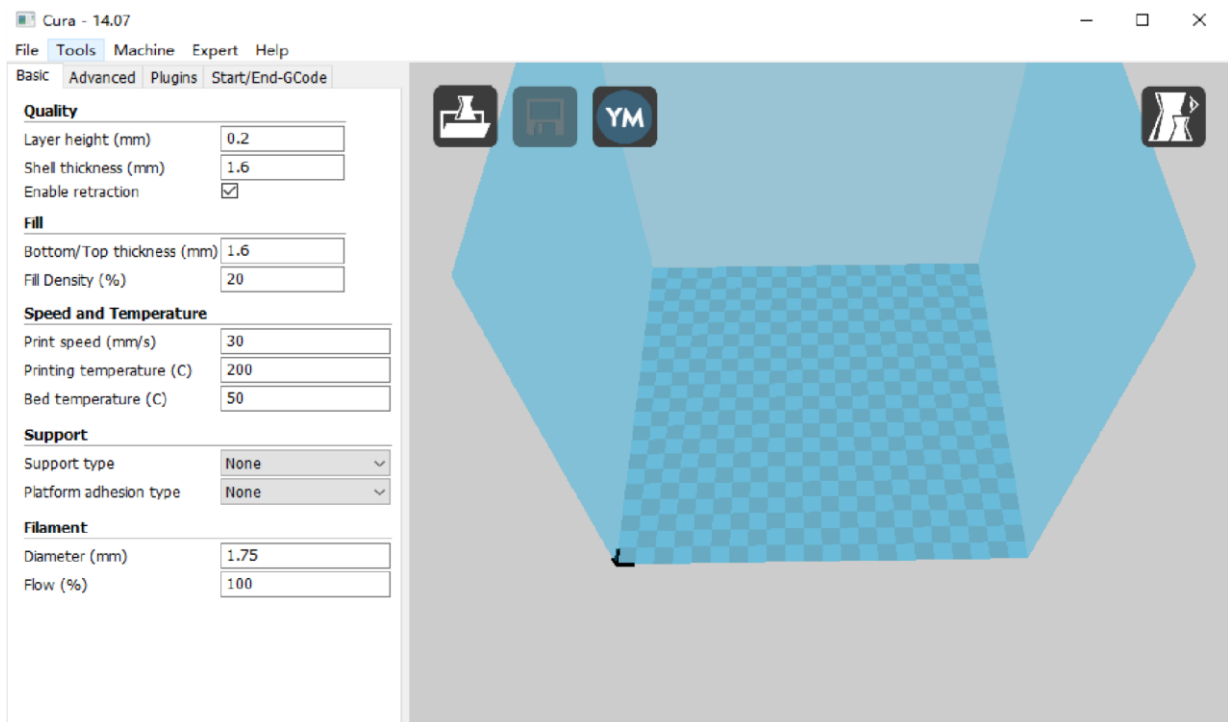
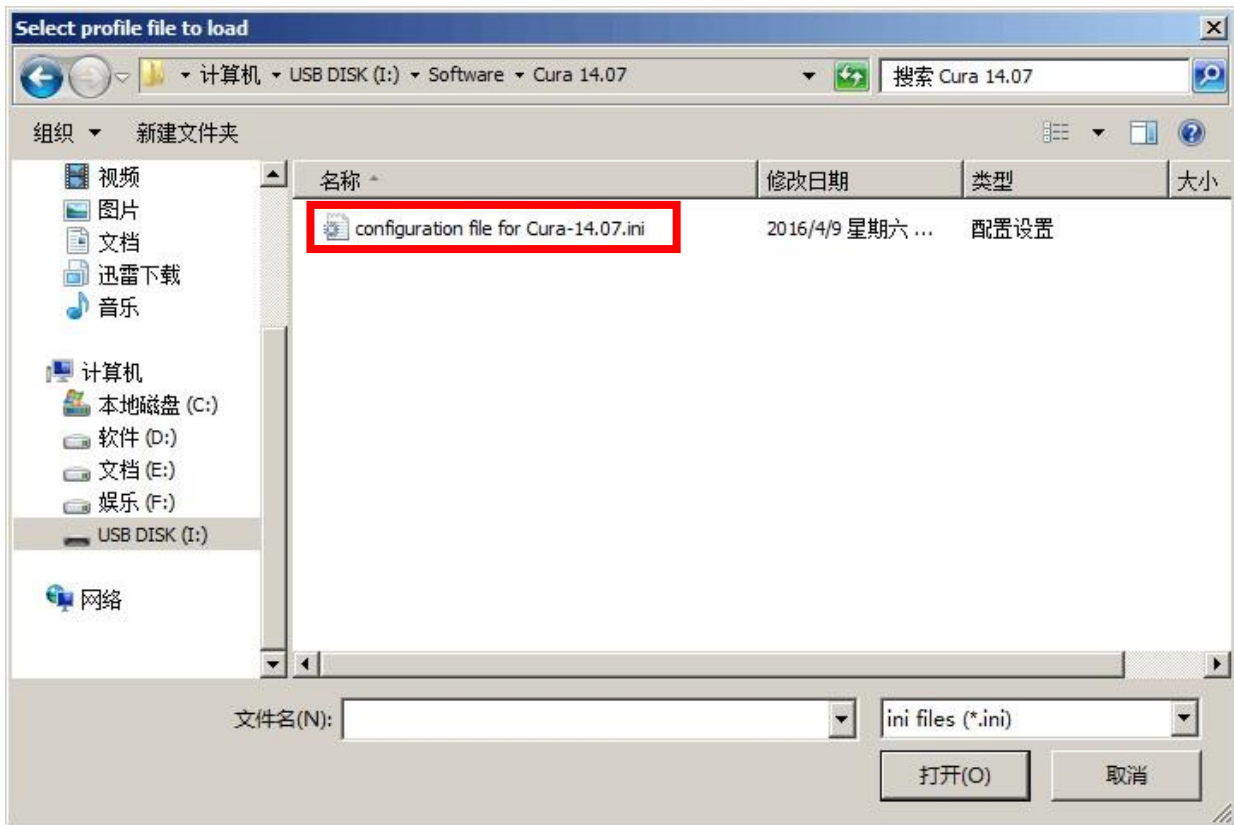

Cura - 14.07

File Tools Machine Expert Help

Basic Copy profile to clipboard

Ma Print all at once

No2 Print one at a time

Retraction

Speed (mm/s) 40

Distance (mm) 4.5

Quality

Initial layer thickness (mm) 0.2

Initial layer line width (%) 100

Cut off object bottom (mm) 0.0

Dual extrusion overlap (mm) 0.15

Speed

Travel speed (mm/s) 50

Bottom layer speed (mm/s) 20

Infill speed (mm/s) 0

Outer shell speed (mm/s) 0.0

Inner shell speed (mm/s) 0.0

Cool

Minimal layer time (sec) 10

Enable cooling fan

1 hour 53 minutes
4.93 meter 15 gram

If print once at a time , it will influence the printing quality, even cause damage to printer. So please choose "Printer at once".

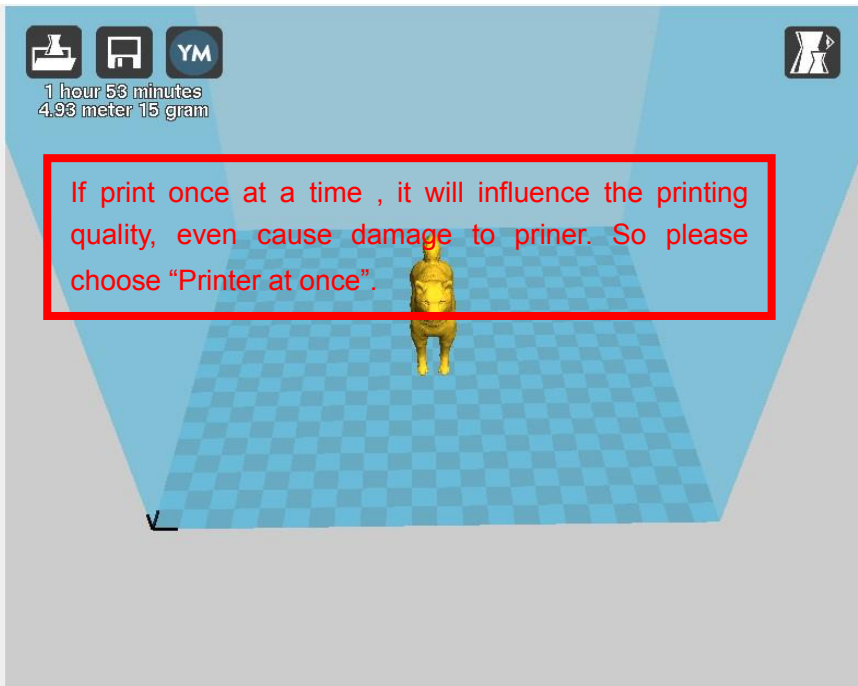

2.3 Layer height settings

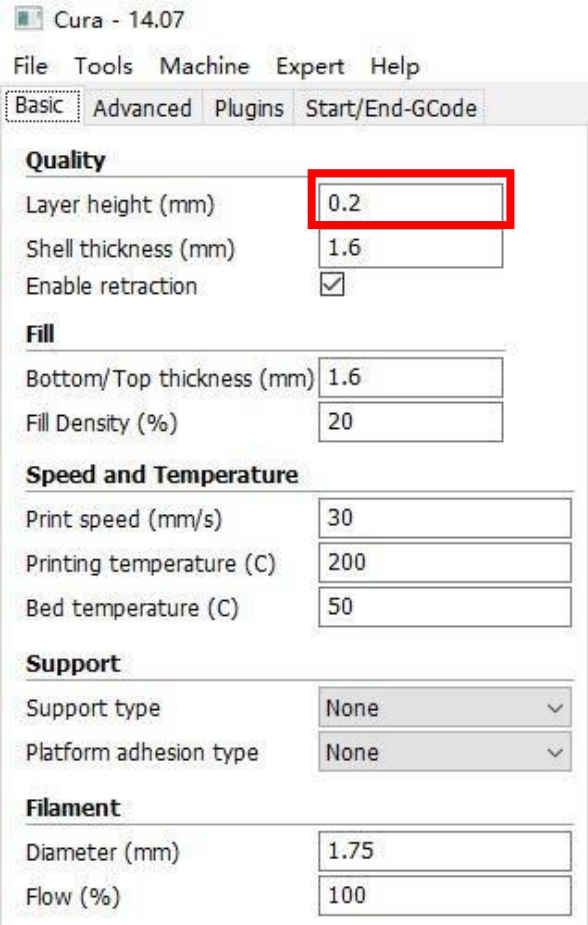

Layer height ; 0.1mm cost long time but have the best printing precision. 0.2mm cost half time compared to 0.1mm , but have general printing precision. 0.3 cost less time with not good precision. It defaults 0.2mm.

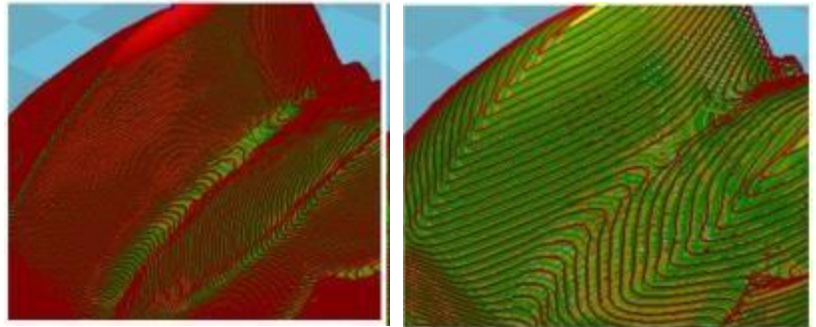

Left; 0.1mm Layer height

Right; 0.2mm Layer height

Layer height setting

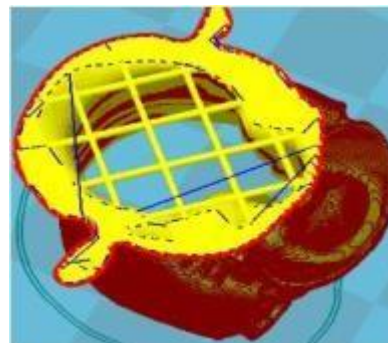

0.8mm



1.2mm

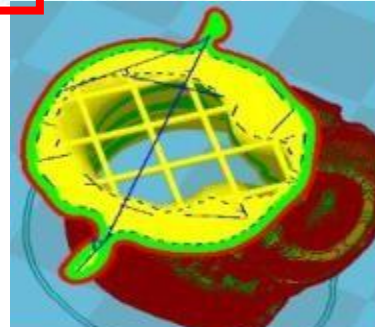

2mm

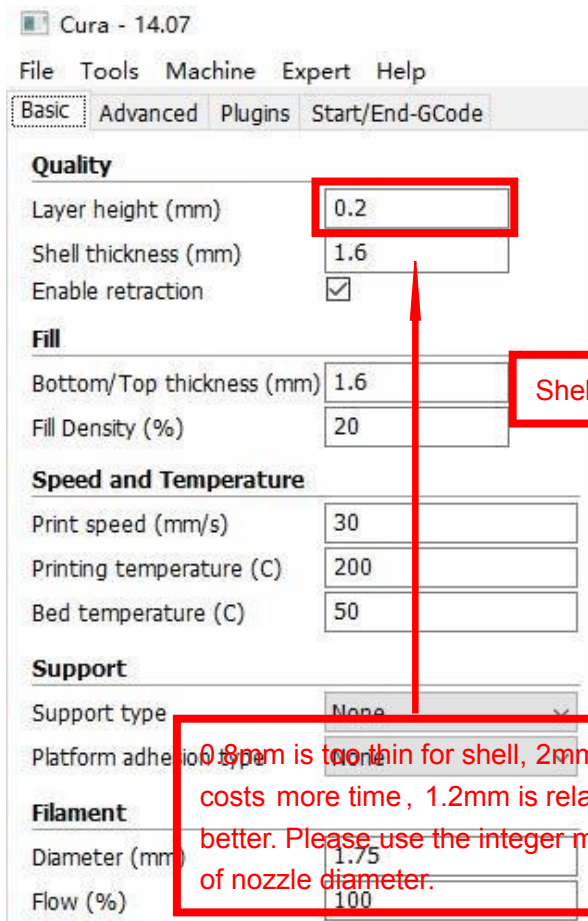

Shell thickness setting

0.8mm is too thin for shell, 2mm shell costs more time , 1.2mm is relatively better. Please use the integer multiple of nozzle diameter.

Cura - 14.07

File Tools Machine Expert Help

Basic Advanced Plugins Start/End-GCode

Quality

Layer height (mm) 0.2

Shell thickness (mm) 1.2

Enable retraction

Fill

Bottom/Top thickness (mm) 1.2

Fill Density (%) 20

Speed and Temperature

Print speed (mm/s) 30

Printing temperature (C) 200

Bed temperature (C) 50

Support

Support type None

Platform adhesion type None

Filament

Diameter (mm) 1.75

Flow (%) 100

Enable retraction to avoid filaments leakage when nozzles move in empty area

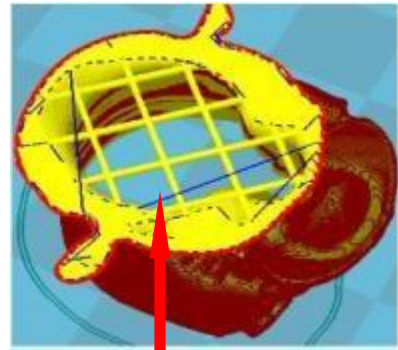

The Blue line is the leak filament

Enable retraction

Cura - 14.07

File Tools Machine Expert Help

Basic Advanced Plugins Start/End-GCode

Quality

Layer height (mm) 0.2

Shell thickness (mm) 1.2

Enable retraction

Fill

Bottom/Top thickness (mm) 1.2

Fill Density (%) 20

Speed and Temperature

Print speed (mm/s) 30

Printing temperature (C) 200

Bed temperature (C) 50

Support

Support type None

Platform adhesion type None

Filament

Diameter (mm) 1.75

Flow (%) 100

When fill density is less than 20%, it's easy for 0.6mm thickness to cause hollow on the top. 1.2mm normally won't have this issue.

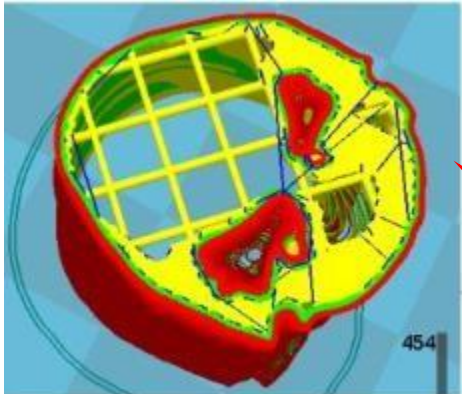

Bottom/Top thickness: 1.2mm

Under the same fill density

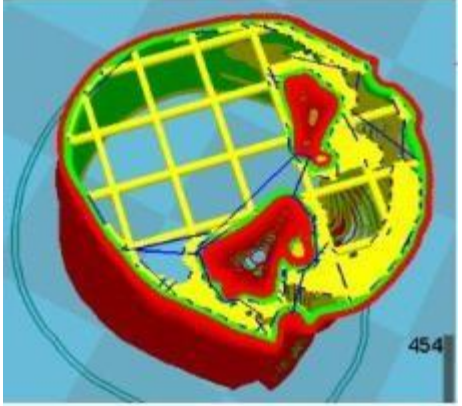

Bottom/Top thickness: 0.6mm

Bottom/Top thickness setting

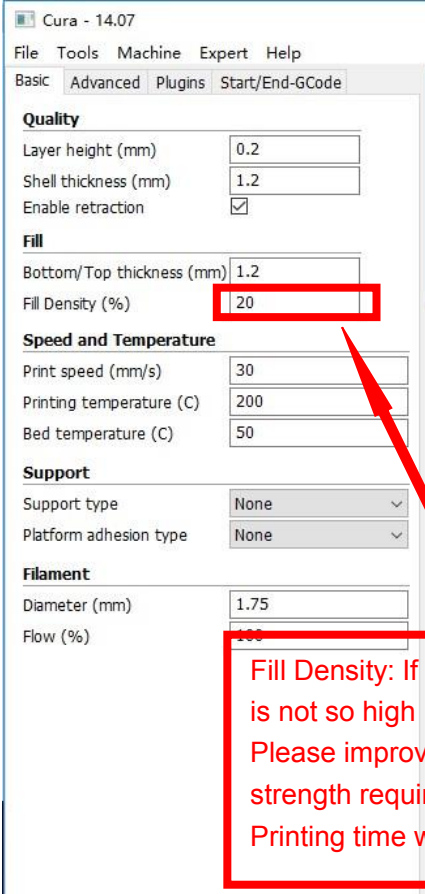

Fill Density: If strength requirement is not so high, set 10% is ok. Please improve fill density when strength requirement gets higher. Printing time will go up as well.

Fill Density Setting

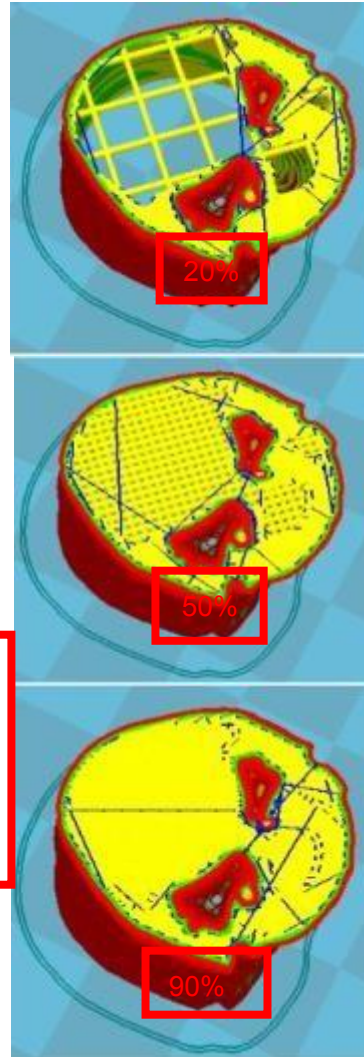

Printing Speed setting

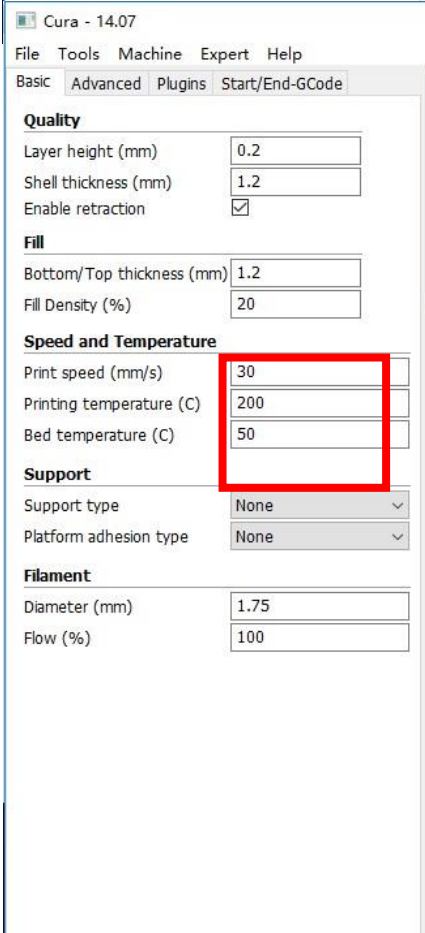

This is default speed. If other settings aren't changed, it prints more accurately while the printing process takes more time.

High printing speed takes less time while it cannot print accurately, making the model have bad quality. Normally 40-60 print speed is suitable for printing.

Printing Temperature

PLA filament temperature setting: nozzle: 190-210 °C hotbed: 40-60°C

ABS filament temperature setting: nozzle: 230-250°C hotbed: 60-90°C

Quality

Layer height (mm)
Shell thickness (mm)
Enable retraction

Fill

Bottom/Top thickness (mm)
Fill Density (%)

Speed and Temperature

Print speed (mm/s)
Printing temperature (C)
Bed temperature (C)

Support

Support type
Platform adhesion type

Filament

Diameter (mm)
Flow (%)

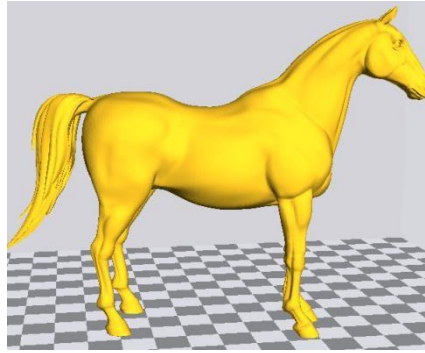

Original Model

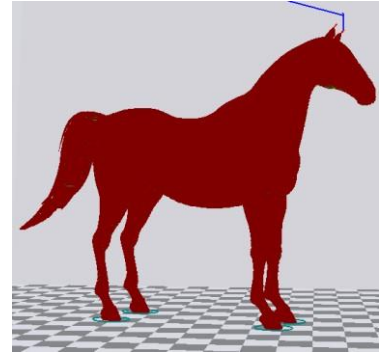

Support type: None

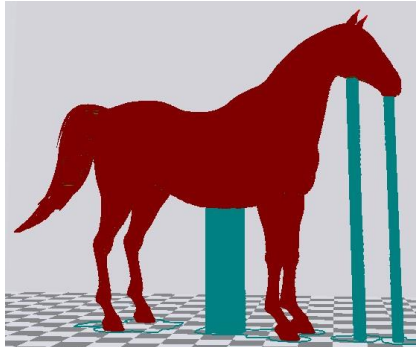

Support type: Touching

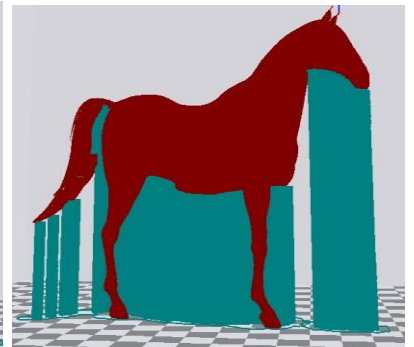

Support type: Everywhere

Support type setting

Attention: Normally we add support to complex model or model with vacant parts. It may have influence on the surface if you choose everywhere. You'd better circle around the model and try to avoid unnecessary support.

Quality

Layer height (mm)	<input type="text" value="0.2"/>
Shell thickness (mm)	<input type="text" value="1.2"/>
Enable retraction	<input checked="" type="checkbox"/>

Fill

Bottom/Top thickness (mm)	<input type="text" value="1.2"/>
Fill Density (%)	<input type="text" value="20"/>

Speed and Temperature

Print speed (mm/s)	<input type="text" value="30"/>
Printing temperature (C)	<input type="text" value="200"/>
Bed temperature (C)	<input type="text" value="50"/>

Support

Support type	<input type="text" value="None"/>
Platform adhesion type	<input type="text" value="None"/>
Filament	<input type="text" value="None"/>
Diameter (mm)	<input type="text" value="Brim"/>
Flow (%)	<input type="text" value="Raft"/>
	<input type="text" value="100"/>

Support setting

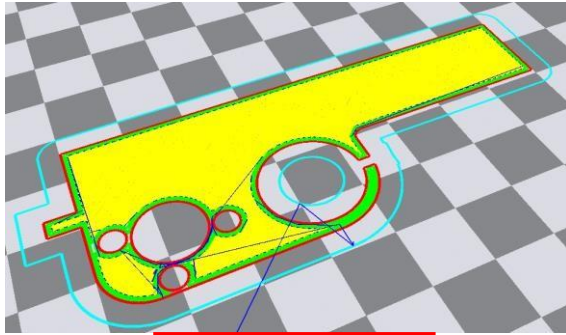

None: no support

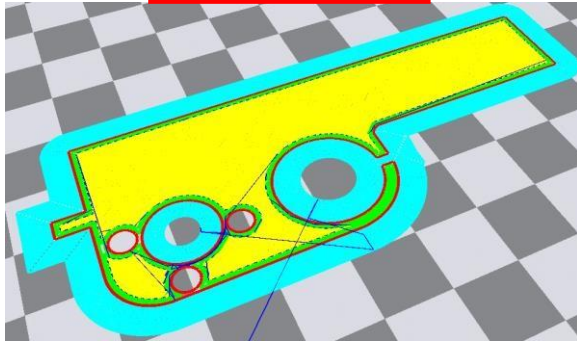

Brim: Touch with the edge

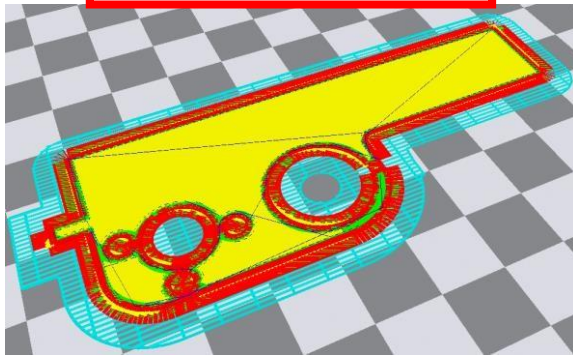

Raft: Totally touch with the bottom

Attention: please choose None if the printing platform is ready and the high temperature adhesive tape is good. Please choose Brim when the model is small . Choosing Raft makes it difficult to seperate model from the platform

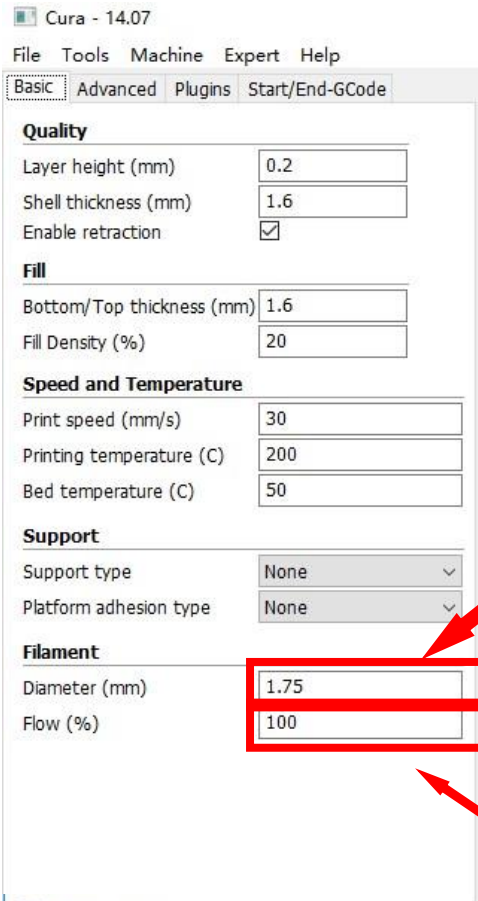

Attention: A8 use 1.75mm filament

Attention:
Flow is proportion of filament , we suggest to use 100
Increasing flow & decrease diameter has the similar effect.
Model surface gets many bumps when flow is too big;model frame gets flimsy if flow is too small.

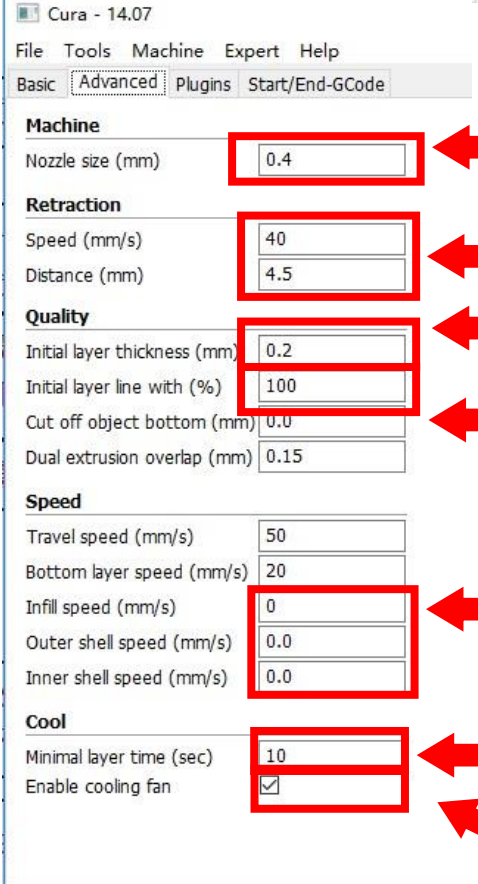

We suggest not to change it , A8 default 0.4mm

We suggest not to change it , or use the date in the picture

We suggest 0.2mm to avoid initial layer tilt,0.3mm is more easy to separate from the platform.

Initial layer line proportion

"0" means using default speed

Min printing time for each layer. When the time is less than 10 , it prints slower. It's better to decrease time when printing thin and long models.

We suggest not choose this when printing ABS.

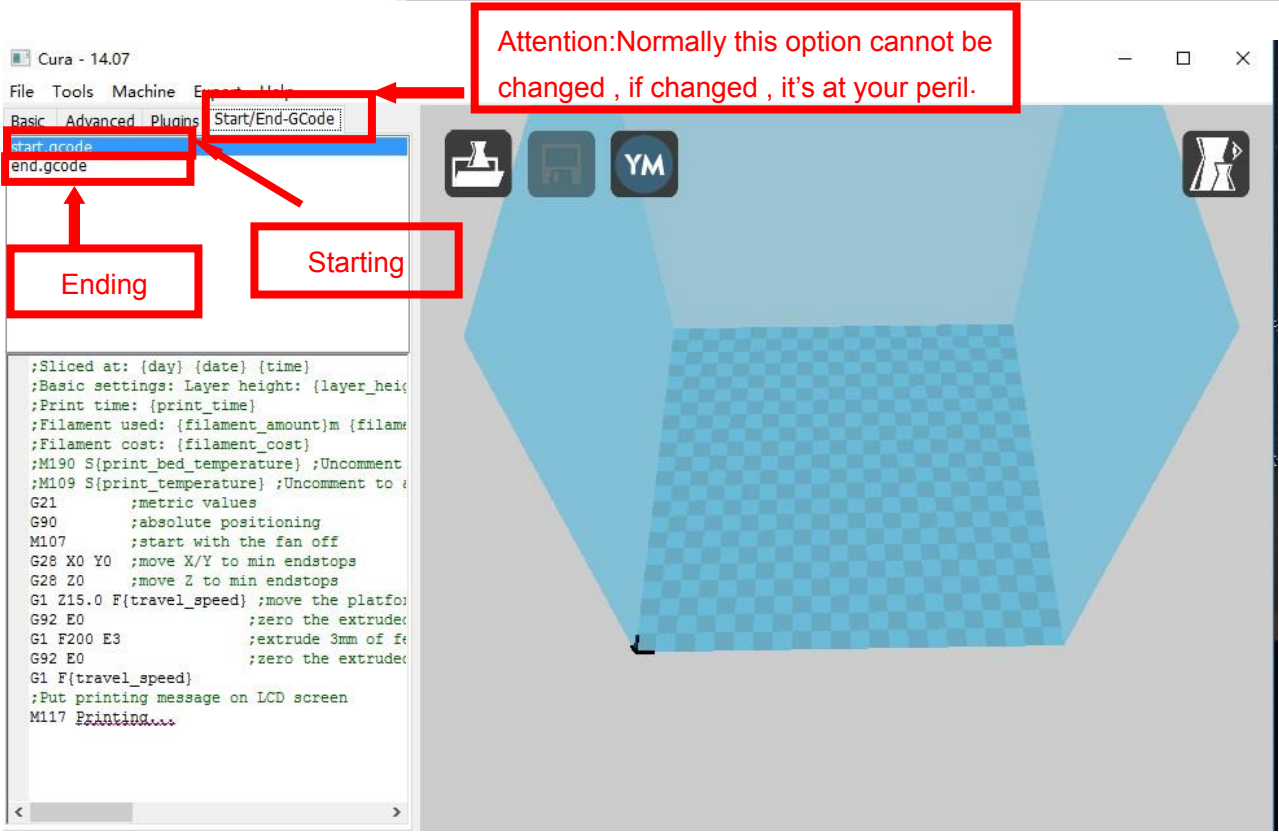
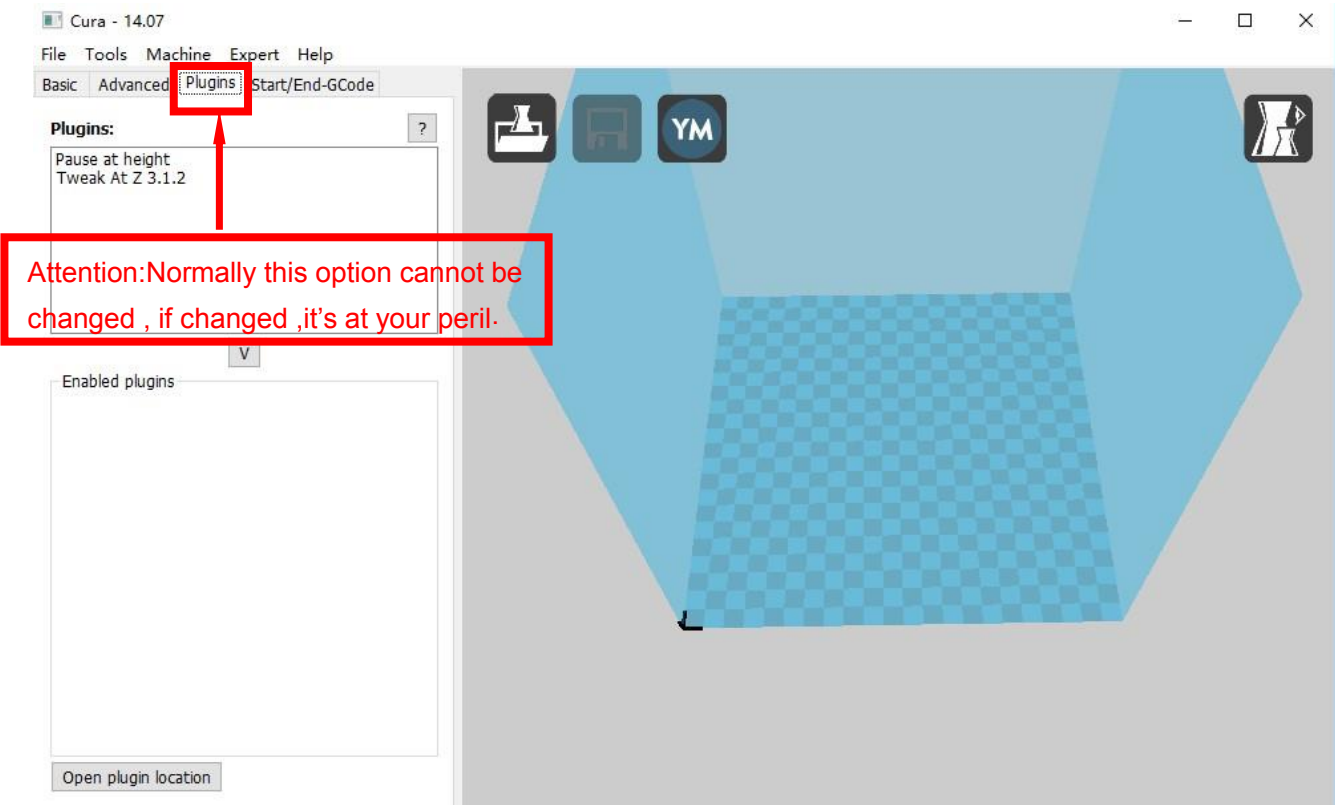

3.Expert Setting

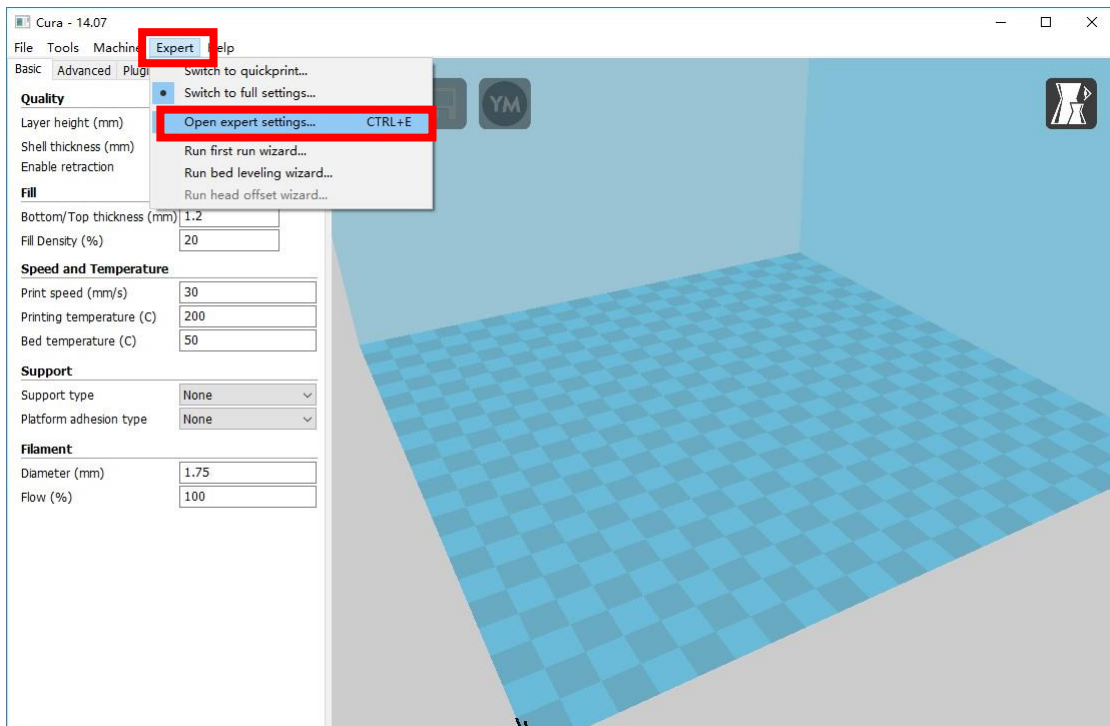
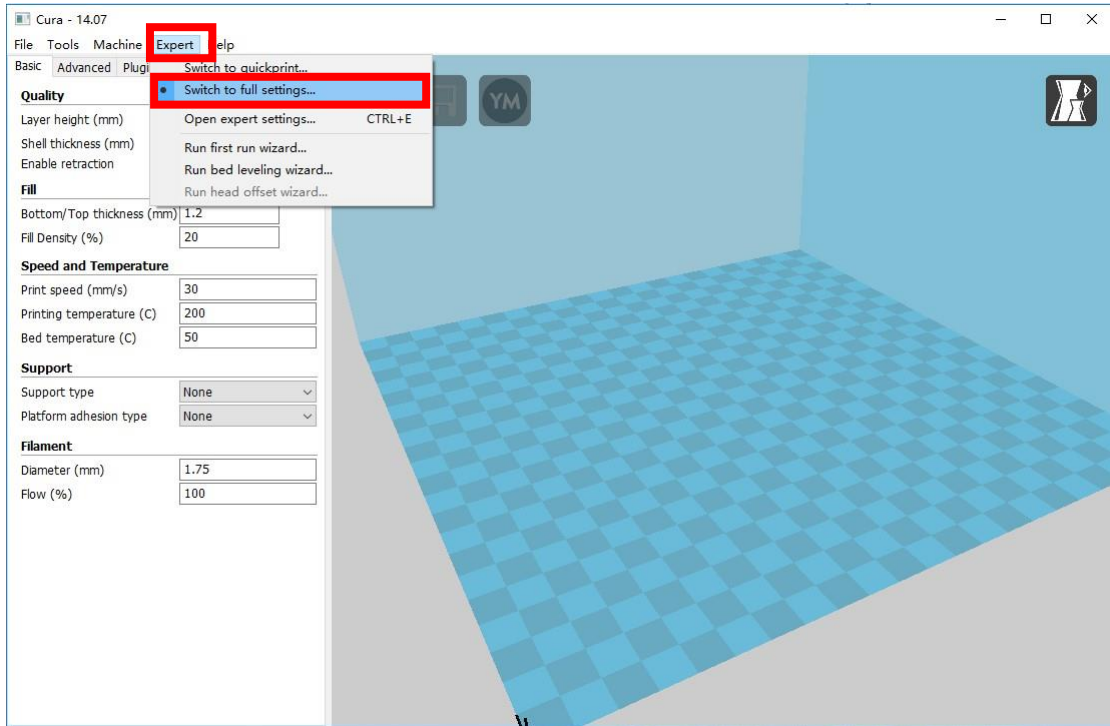

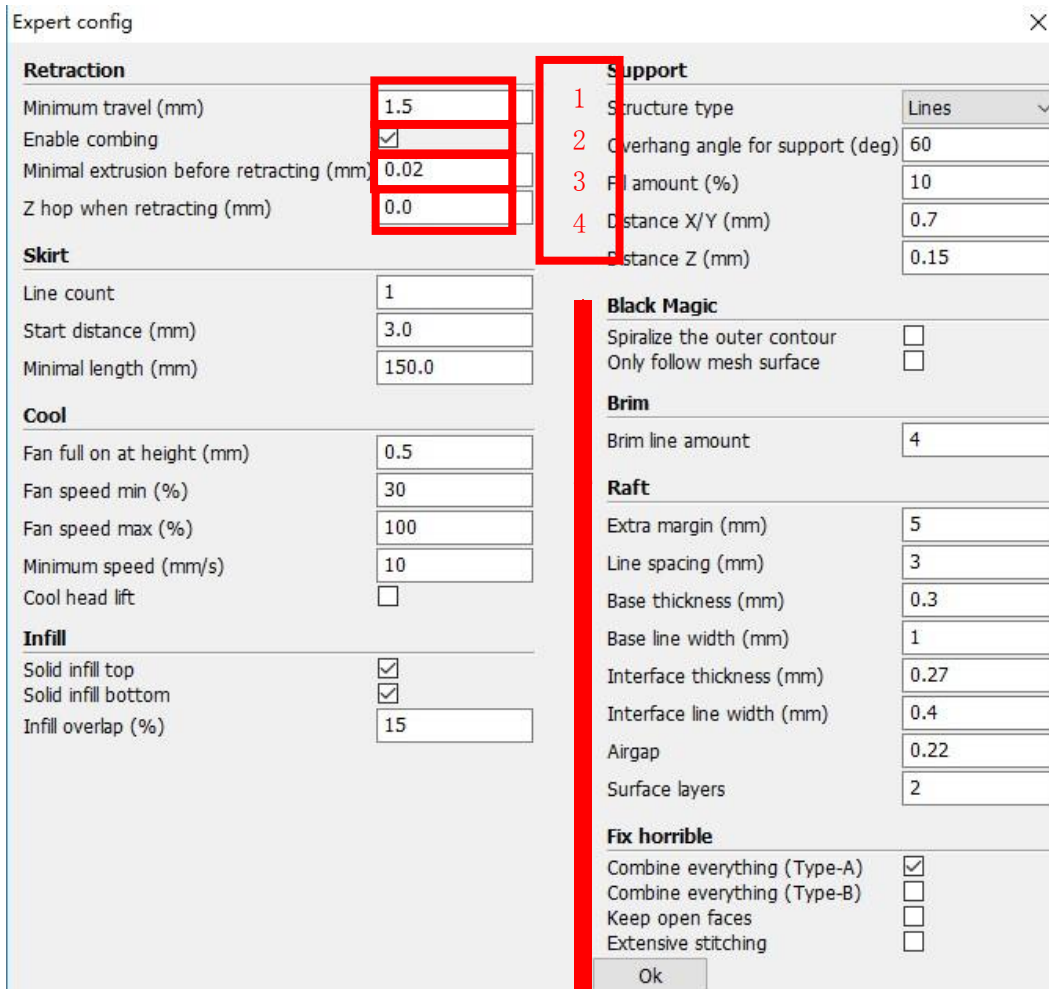

1. The minimum length before retraction . Used to avoid frequent retraction. No need to change.
2. Enable Combing: Digital for surface quality , the nozzle will try not to go through surface , that's why Cura is better than Slic3r.
3. Minimum extrusion length , to avoid frequent extrusion.
4. The height extruder rise in the retraction . If you need to set this option , 2mm is suitable .

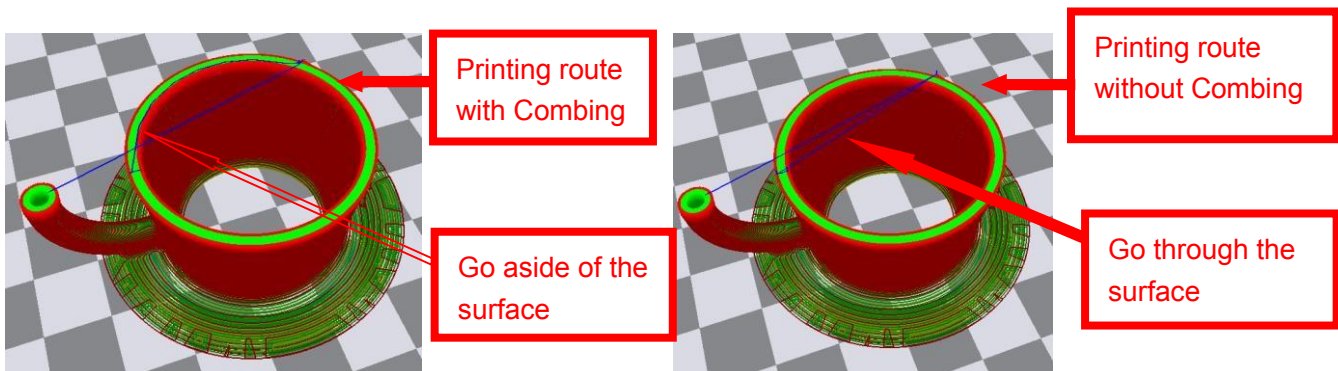

Expert config ×

Retraction	
Minimum travel (mm)	1.5
Enable combing	<input checked="" type="checkbox"/>
Minimal extrusion before retracting (mm)	0.02
Z hop when retracting (mm)	0.0

Skirt	
Line count	1
Start distance (mm)	3.0
Minimal length (mm)	150.0

Cool	
Fan full on at height (mm)	0.5
Fan speed min (%)	30
Fan speed max (%)	100
Minimum speed (mm/s)	10
Cool head lift	<input type="checkbox"/>

Infill	
Solid infill top	<input checked="" type="checkbox"/>
Solid infill bottom	<input checked="" type="checkbox"/>
Infill overlap (%)	15

Support	
Structure type	Lines
Overhang angle for support (deg)	60
Fill amount (%)	10
Distance X/Y (mm)	0.7
Distance Z (mm)	0.15

Black Magic	
Spiralize the outer contour	<input type="checkbox"/>
Only follow mesh surface	<input type="checkbox"/>

Brim	
Brim line amount	4

Raft	
Extra margin (mm)	5
Line spacing (mm)	3
Base thickness (mm)	0.3
Base line width (mm)	1
Interface thickness (mm)	0.27
Interface line width (mm)	0.4
Airgap	0.22
Surface layers	2

Fix horrible	
Combine everything (Type-A)	<input checked="" type="checkbox"/>
Combine everything (Type-B)	<input type="checkbox"/>
Keep open faces	<input type="checkbox"/>
Extensive stitching	<input type="checkbox"/>

Ok

Skirt is to avoid extruder unfilled before printing , and it appears only when platform attachment type is None. Normally "1" is ok . Change it to "0" when your model reaches the maximum size , or the printing size will be too big.

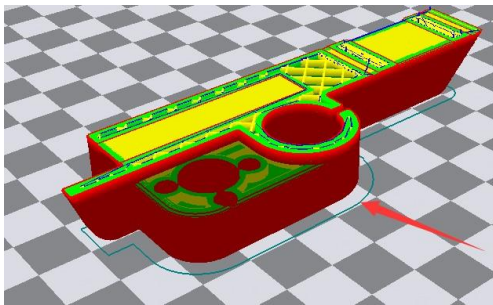

Peripheral line quantity: 1
Start distance: 3

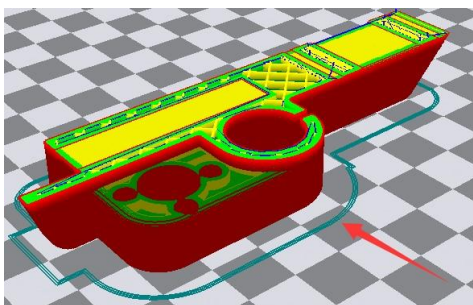

Peripheral line quantity: 1
Start distance: 3

Expert config ×

Retraction	
Minimum travel (mm)	1.5
Enable combing	<input checked="" type="checkbox"/>
Minimal extrusion before retracting (mm)	0.02
Z hop when retracting (mm)	0.0

Skirt	
Line count	1
Start distance (mm)	3.0
Minimal length (mm)	150.0

Cool	
Fan full on at height (mm)	0.5
Fan speed min (%)	30
Fan speed max (%)	100
Minimum speed (mm/s)	10
Cool head lift	<input type="checkbox"/>

Infill	
Solid infill top	<input checked="" type="checkbox"/>
Solid infill bottom	<input checked="" type="checkbox"/>
Infill overlap (%)	15

Support	
Structure type	Lines
Overhang angle for support (deg)	60
Fill amount (%)	10
Distance X/Y (mm)	0.7
Distance Z (mm)	0.15

Black Magic	
Spiralize the outer contour	<input type="checkbox"/>
Only follow mesh surface	<input type="checkbox"/>

Brim	
Brim line amount	4

Raft	
Extra margin (mm)	5
Line spacing (mm)	3
Base thickness (mm)	0.3
Base line width (mm)	1
Interface thickness (mm)	0.27
Interface line width (mm)	0.4
Airgap	0.22
Surface layers	2

Fix horrible	
Combine everything (Type-A)	<input checked="" type="checkbox"/>
Combine everything (Type-B)	<input type="checkbox"/>
Keep open faces	<input type="checkbox"/>
Extensive stitching	<input type="checkbox"/>

Ok

1. To ensure the attachment of model to platform , fan won't start at the beginning.
- 2-4. Fan speed min & max : If they are not equal , the soft ware will choose a suitable speed during them.
5. Condition to choose cool head lift : When it's printing with the minimum speed but still cannot reach the minimum time , you need to choose cool head lift . But it may cause filament leak.

Expert config ×

Retraction	
Minimum travel (mm)	1.5
Enable combing	<input checked="" type="checkbox"/>
Minimal extrusion before retracting (mm)	0.02
Z hop when retracting (mm)	0.0

Skirt	
Line count	1
Start distance (mm)	3.0
Minimal length (mm)	150.0

Cool	
Fan full on at height (mm)	0.5
Fan speed min (%)	30
Fan speed max (%)	100
Minimum speed (mm/s)	10
Cool head lift	<input type="checkbox"/>

Infill	
Solid infill top	<input checked="" type="checkbox"/>
Solid infill bottom	<input checked="" type="checkbox"/>
Infill overlap (%)	15

Support	
Structure type	Lines
Overhang angle for support (deg)	60
Fill amount (%)	10
Distance X/Y (mm)	0.7
Distance Z (mm)	0.15

Black Magic	
Spiralize the outer contour	<input type="checkbox"/>
Only follow mesh surface	<input type="checkbox"/>

Brim	
Brim line amount	4

Raft	
Extra margin (mm)	5
Line spacing (mm)	3
Base thickness (mm)	0.3
Base line width (mm)	1
Interface thickness (mm)	0.27
Interface line width (mm)	0.4
Airgap	0.22
Surface layers	2

Fix horrible	
Combine everything (Type-A)	<input checked="" type="checkbox"/>
Combine everything (Type-B)	<input type="checkbox"/>
Keep open faces	<input type="checkbox"/>
Extensive stitching	<input type="checkbox"/>

Ok

If no solid infill top , the only qualification is the surface thickness .
Please check the detail below.

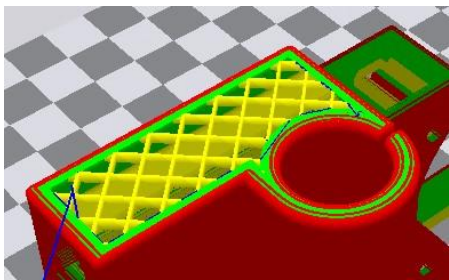

No solid infill top

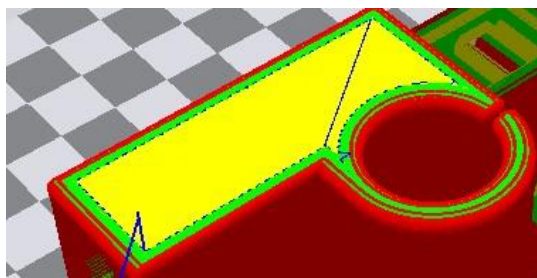

With solid infill top

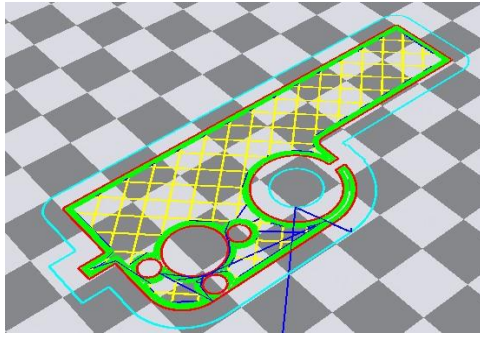

No solid infill bottom

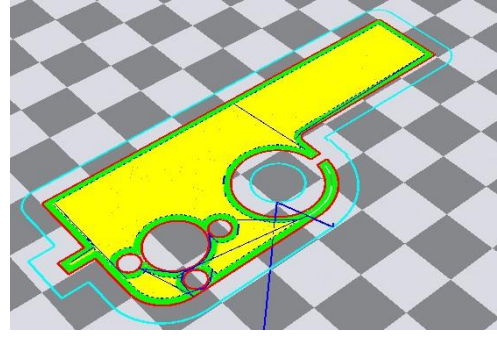

With solid infill bottom

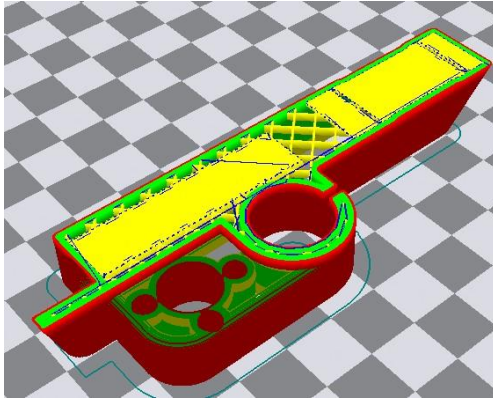

Infill overlap: 20

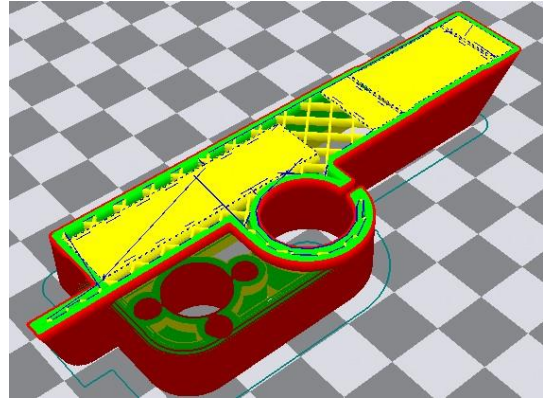

Infill overlap: 40

Expert config ×

Retraction	
Minimum travel (mm)	1.5
Enable combing	<input checked="" type="checkbox"/>
Minimal extrusion before retracting (mm)	0.02
Z hop when retracting (mm)	0.0
Skirt	
Line count	1
Start distance (mm)	3.0
Minimal length (mm)	150.0
Cool	
Fan full on at height (mm)	0.5
Fan speed min (%)	30
Fan speed max (%)	100
Minimum speed (mm/s)	10
Cool head lift	<input type="checkbox"/>
Infill	
Solid infill top	<input checked="" type="checkbox"/>
Solid infill bottom	<input checked="" type="checkbox"/>
Infill overlap (%)	15
Support	
Structure type	Lines
Overhang angle for support (deg)	60
Fill amount (%)	10
Distance X/Y (mm)	0.7
Distance Z (mm)	0.15
Black Magic	
Spiralize the outer contour	<input type="checkbox"/>
Only follow mesh surface	<input type="checkbox"/>
Brim	
Brim line amount	4
Raft	
Extra margin (mm)	5
Line spacing (mm)	3
Base thickness (mm)	0.3
Base line width (mm)	1
Interface thickness (mm)	0.27
Interface line width (mm)	0.4
Airgap	0.22
Surface layers	2
Fix horrible	
Combine everything (Type-A)	<input checked="" type="checkbox"/>
Combine everything (Type-B)	<input type="checkbox"/>
Keep open faces	<input type="checkbox"/>
Extensive stitching	<input type="checkbox"/>
Ok	

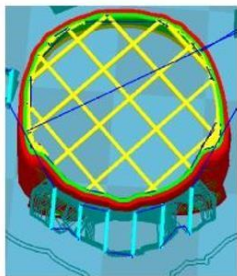

Structure types:lines
Infill covertap: 15
Distance X/Y: 0.7

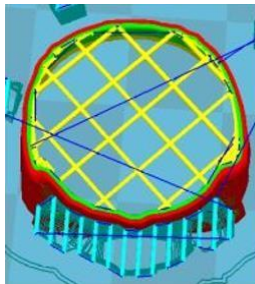

Structure types:lines
Infill covertap: 30
Distance X/Y: 0.7

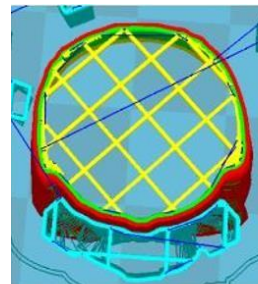

Structure types:grids
Infill covertap: 15
Distance X/Y: 0.7

These above are examples , you can set these options according to actual requirements. The biggest progress Cura has made is the kinds of support structure types , making it easier to seperate from the model.

Expert config ×

Retraction	
Minimum travel (mm)	1.5
Enable combing	<input checked="" type="checkbox"/>
Minimal extrusion before retracting (mm)	0.02
Z hop when retracting (mm)	0.0

Skirt	
Line count	1
Start distance (mm)	3.0
Minimal length (mm)	150.0

Cool	
Fan full on at height (mm)	0.5
Fan speed min (%)	30
Fan speed max (%)	100
Minimum speed (mm/s)	10
Cool head lift	<input type="checkbox"/>

Infill	
Solid infill top	<input checked="" type="checkbox"/>
Solid infill bottom	<input checked="" type="checkbox"/>
Infill overlap (%)	15

Support	
Structure type	Lines
Overhang angle for support (deg)	60
Fill amount (%)	10
Distance X/Y (mm)	0.7
Distance Z (mm)	0.15

Black Magic	
Spiralize the outer contour	<input type="checkbox"/>
Only follow mesh surface	<input type="checkbox"/>

Brim	
Brim line amount	4

Raft	
Extra margin (mm)	5
Line spacing (mm)	3
Base thickness (mm)	0.3
Base line width (mm)	1
Interface thickness (mm)	0.27
Interface line width (mm)	0.4
Airgap	0.22
Surface layers	2

Fix horrible	
Combine everything (Type-A)	<input checked="" type="checkbox"/>
Combine everything (Type-B)	<input type="checkbox"/>
Keep open faces	<input type="checkbox"/>
Extensive stitching	<input type="checkbox"/>

Ok



60°



45°

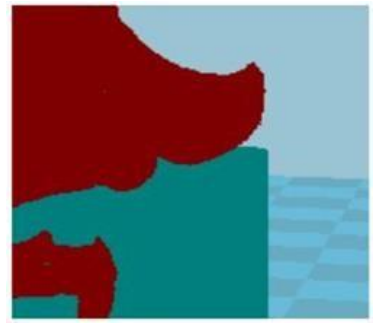

30°

It's difficult to separate if the distance between support and the supported place is too close; The surface will be influenced if the distance is too far.

Different angle will generate different support, you can try the examples we provide above which will have different effect.

Expert config ✕

Retraction	
Minimum travel (mm)	1.5
Enable combing	<input checked="" type="checkbox"/>
Minimal extrusion before retracting (mm)	0.02
Z hop when retracting (mm)	0.0

Skirt	
Line count	1
Start distance (mm)	3.0
Minimal length (mm)	150.0

Cool	
Fan full on at height (mm)	0.5
Fan speed min (%)	30
Fan speed max (%)	100
Minimum speed (mm/s)	10
Cool head lift	<input type="checkbox"/>

Infill	
Solid infill top	<input checked="" type="checkbox"/>
Solid infill bottom	<input checked="" type="checkbox"/>
Infill overlap (%)	15

Support	
Structure type	Lines ▼
Overhang angle for support (deg)	60
Fill amount (%)	10
Distance X/Y (mm)	0.7
Distance Z (mm)	0.15

Black Magic	
Spiralize the outer contour	<input type="checkbox"/>
Only follow mesh surface	<input type="checkbox"/>

Brim	
Brim line amount	4

Raft	
Extra margin (mm)	5
Line spacing (mm)	3
Base thickness (mm)	0.3
Base line width (mm)	1
Interface thickness (mm)	0.27
Interface line width (mm)	0.4
Airgap	0.22
Surface layers	2

Fix horrible	
Combine everything (Type-A)	<input checked="" type="checkbox"/>
Combine everything (Type-B)	<input type="checkbox"/>
Keep open faces	<input type="checkbox"/>
Extensive stitching	<input type="checkbox"/>

Ok

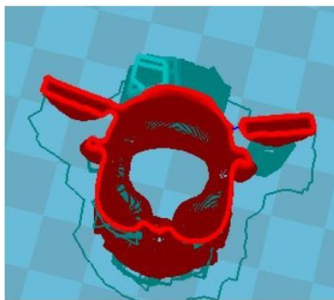

When choosing “Spiralize the outer contour” : Z axis rises while X,Y axis moves , and only a hollow bottom and a single layer of surface.

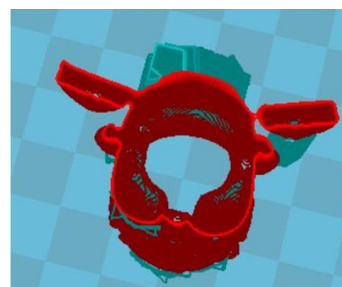

When choosing “Only follow mesh surface” : The nozzle prints along the surface.

Attention: The software defaults not open the option above , you'd better not turn it on .

Expert config ×

Retraction	
Minimum travel (mm)	1.5
Enable combing	<input checked="" type="checkbox"/>
Minimal extrusion before retracting (mm)	0.02
Z hop when retracting (mm)	0.0

Skirt	
Line count	1
Start distance (mm)	3.0
Minimal length (mm)	150.0

Cool	
Fan full on at height (mm)	0.5
Fan speed min (%)	30
Fan speed max (%)	100
Minimum speed (mm/s)	10
Cool head lift	<input type="checkbox"/>

Infill	
Solid infill top	<input checked="" type="checkbox"/>
Solid infill bottom	<input checked="" type="checkbox"/>
Infill overlap (%)	15

Support	
Structure type	Lines
Overhang angle for support (deg)	60
Fill amount (%)	10
Distance X/Y (mm)	0.7
Distance Z (mm)	0.15

Black Magic	
Spiralize the outer contour	<input type="checkbox"/>
Only follow mesh surface	<input type="checkbox"/>

Brim	
Brim line amount	4

Raft	
Extra margin (mm)	5
Line spacing (mm)	3
Base thickness (mm)	0.3
Base line width (mm)	1
Interface thickness (mm)	0.27
Interface line width (mm)	0.4
Airgap	0.22
Surface layers	2

Fix horrible	
Combine everything (Type-A)	<input checked="" type="checkbox"/>
Combine everything (Type-B)	<input type="checkbox"/>
Keep open faces	<input type="checkbox"/>
Extensive stitching	<input type="checkbox"/>

Ok

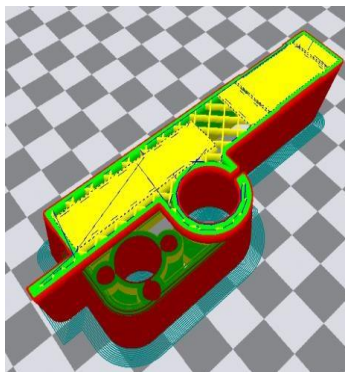

Brim line amount: 10

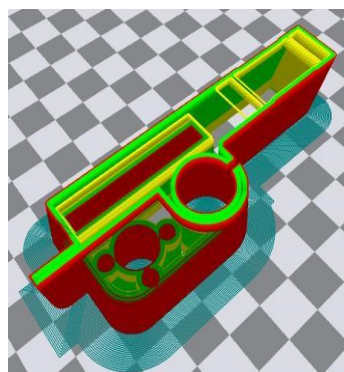

Brim line amount: 20

Guidance to use Brim if needed: Expert → Expert Settings → Support → Support Types → Brim.
 The images above are only for reference , please set the parameter according to actual requirement.

Expert config ×

Retraction	
Minimum travel (mm)	1.5
Enable combing	<input checked="" type="checkbox"/>
Minimal extrusion before retracting (mm)	0.02
Z hop when retracting (mm)	0.0

Skirt	
Line count	1
Start distance (mm)	3.0
Minimal length (mm)	150.0

Cool	
Fan full on at height (mm)	0.5
Fan speed min (%)	30
Fan speed max (%)	100
Minimum speed (mm/s)	10
Cool head lift	<input type="checkbox"/>

Infill	
Solid infill top	<input checked="" type="checkbox"/>
Solid infill bottom	<input checked="" type="checkbox"/>
Infill overlap (%)	15

Support	
Structure type	Lines ▾
Overhang angle for support (deg)	60
Fill amount (%)	10
Distance X/Y (mm)	0.7
Distance Z (mm)	0.15

Black Magic	
Spiralize the outer contour	<input type="checkbox"/>
Only follow mesh surface	<input type="checkbox"/>

Brim	
Brim line amount	4

Raft	
Extra margin (mm)	5
Line spacing (mm)	3
Base thickness (mm)	0.3
Base line width (mm)	1
Interface thickness (mm)	0.27
Interface line width (mm)	0.4
Airgap	0.22
Surface layers	2

Fix horrible	
Combine everything (Type-A)	<input checked="" type="checkbox"/>
Combine everything (Type-B)	<input type="checkbox"/>
Keep open faces	<input type="checkbox"/>
Extensive stitching	<input type="checkbox"/>

Guidance to use Raft if needed: Expert → Expert Settings → Support → Support Types → Raft.

The images above are only for reference , please set the parameter according to actual requirement.

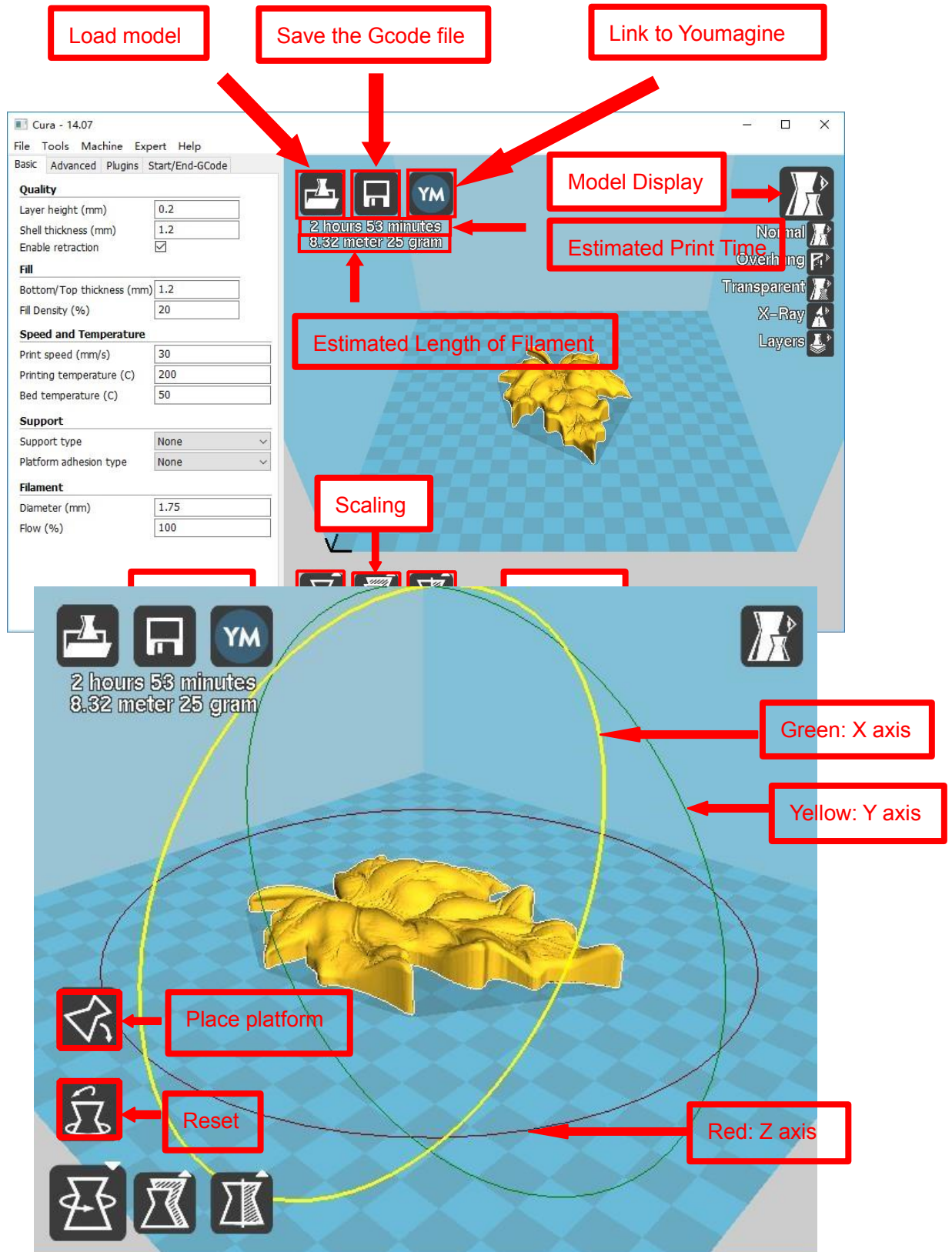

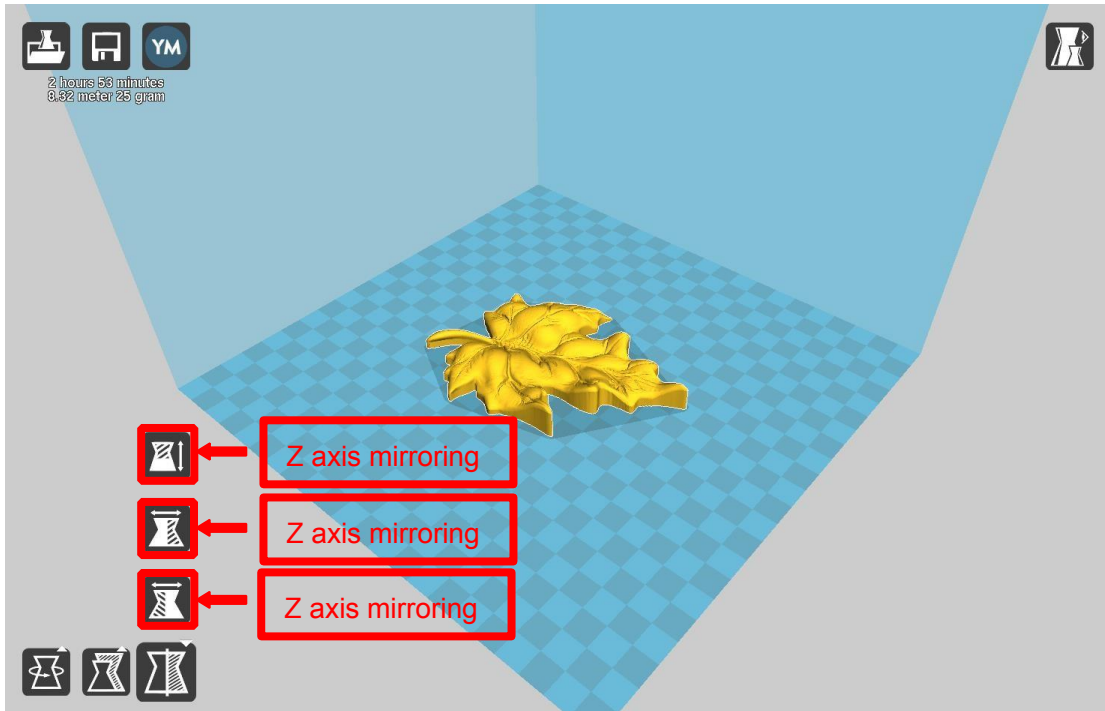
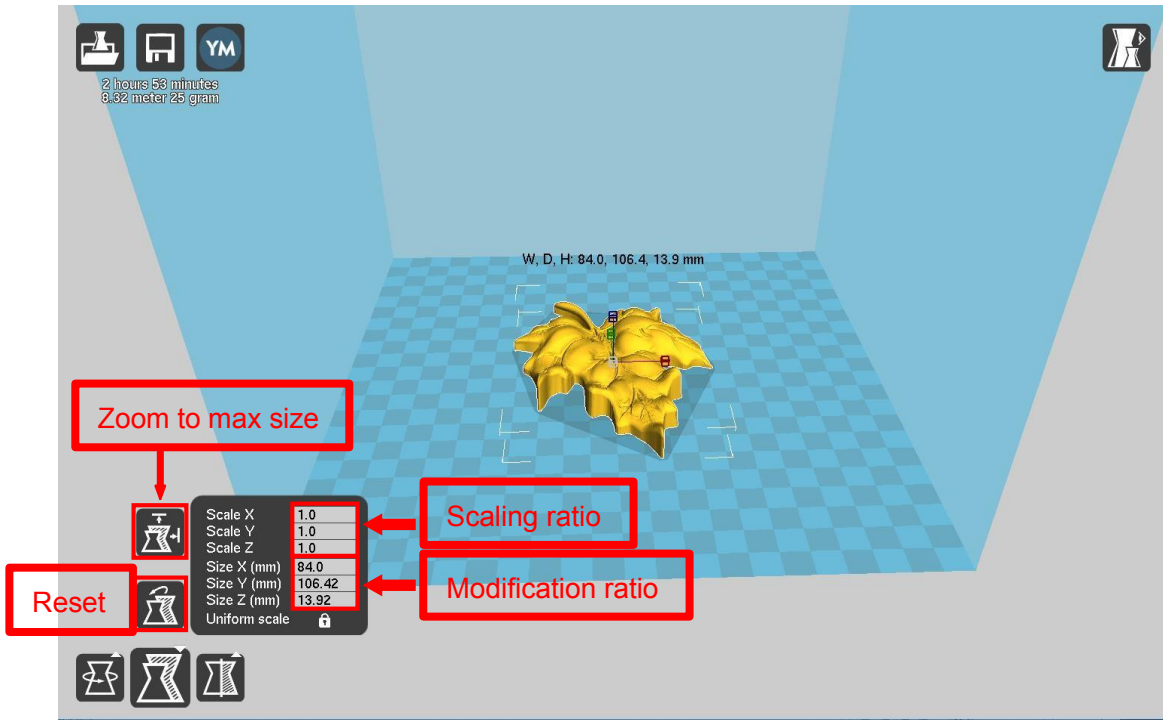

Attention: The model will be converse after mirroring.

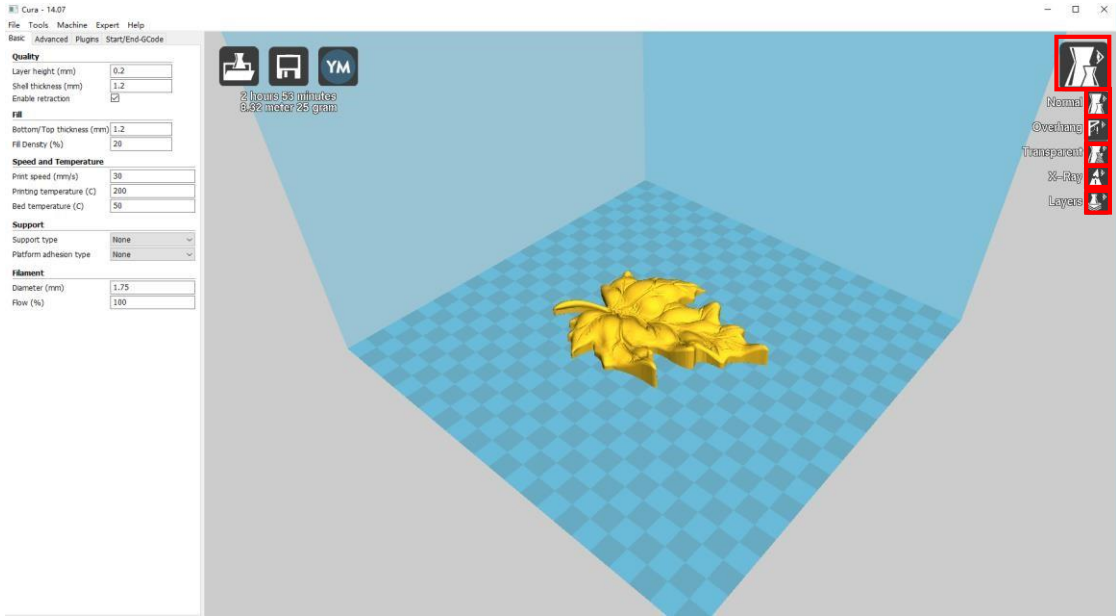

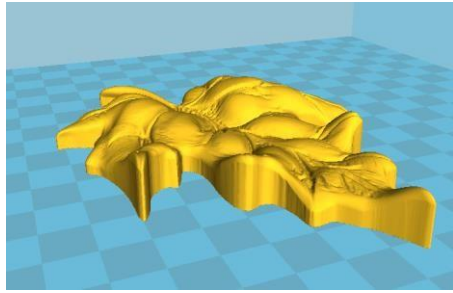

Normal: Most used.

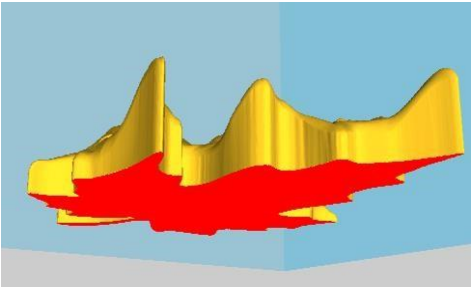

Overhang: Used to see the vacant part.

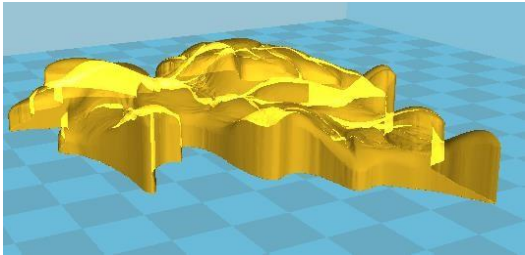

Transparent

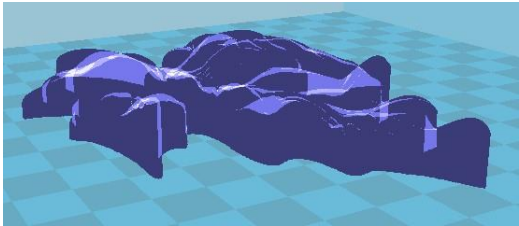

X-Ray

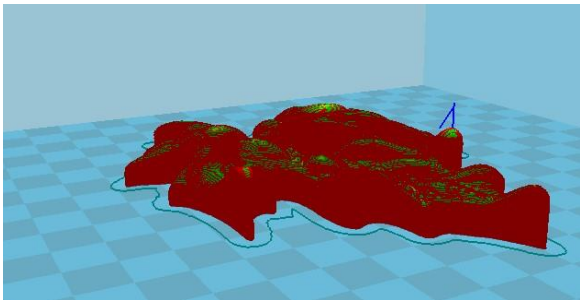

Layers:Used to simulate the effect of each layer and the path.

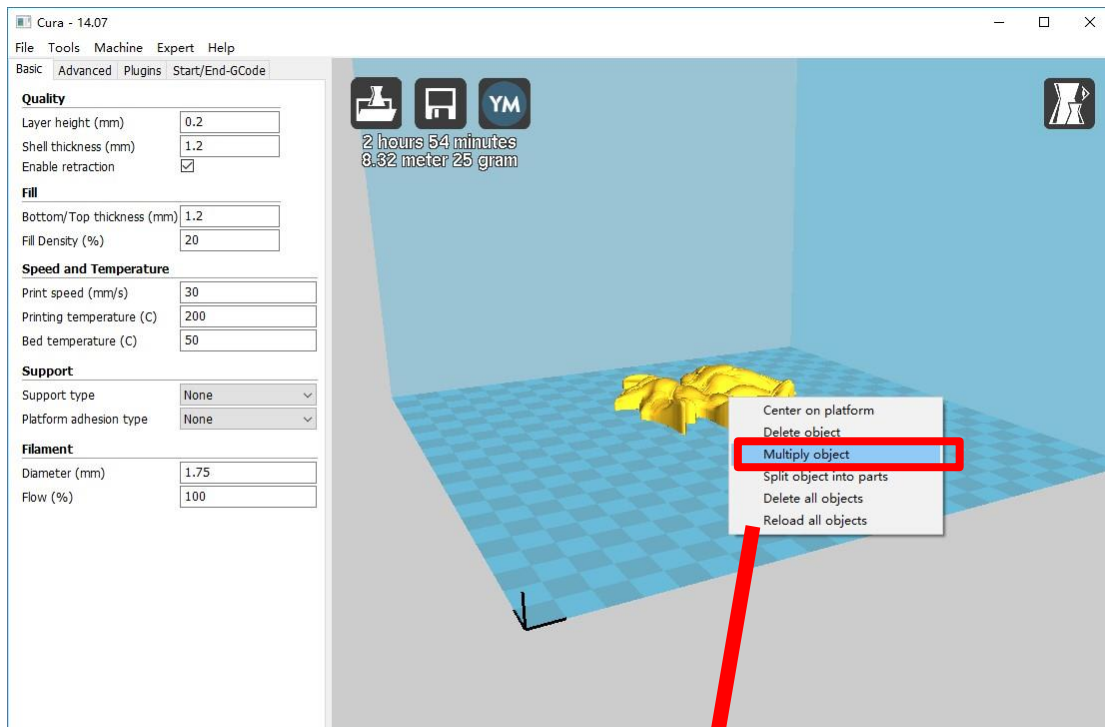

Right click model → Left click "Multiply object" → Example: copy 4 model

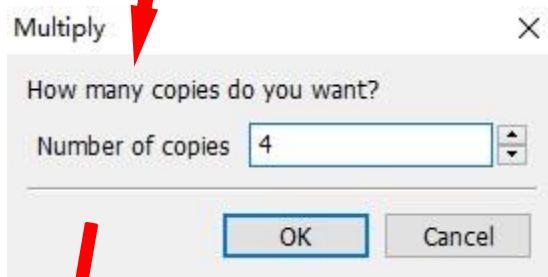

5 models in total

Attention: You can try other functions by yourself.

D. Printing Operation 1.

Introduction of Display

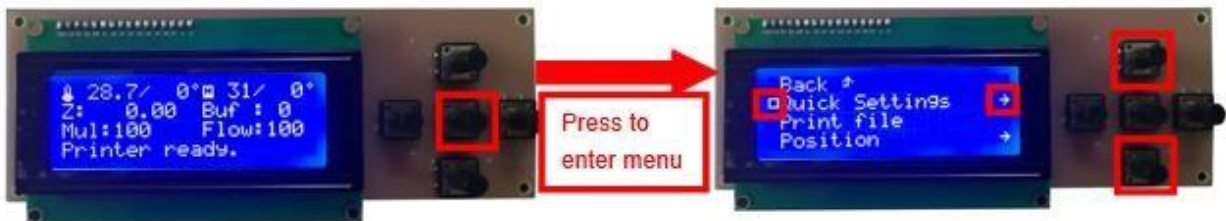
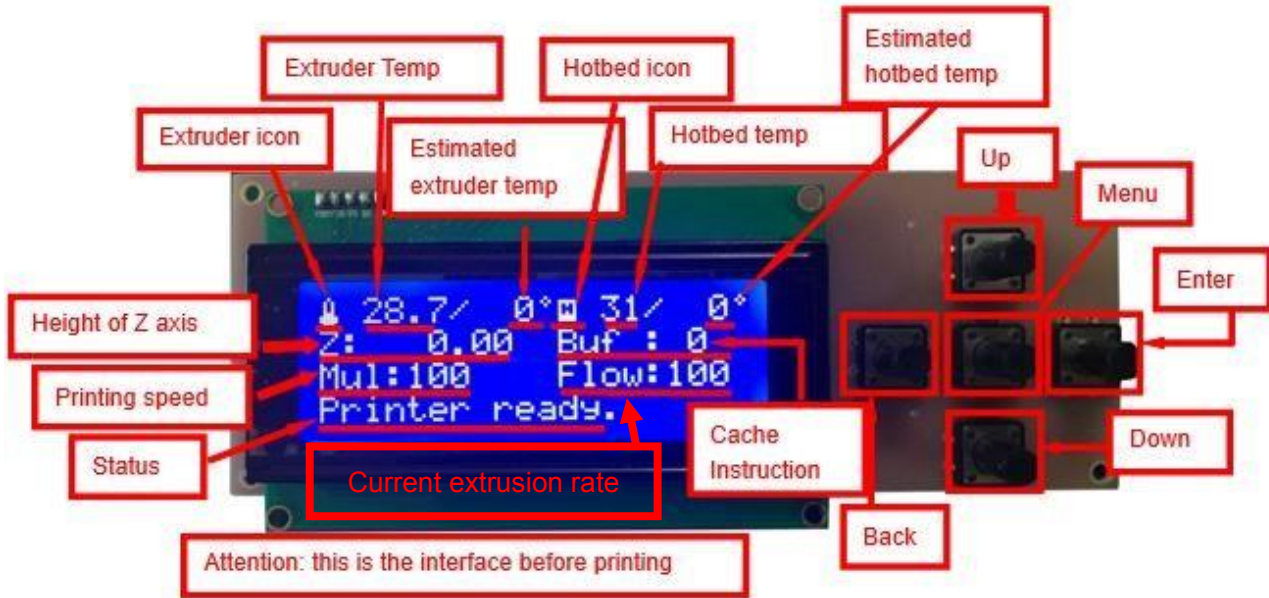

Whole interface of menu

 : it means you can enter this option to other settings

 : it represents you can enter this option.

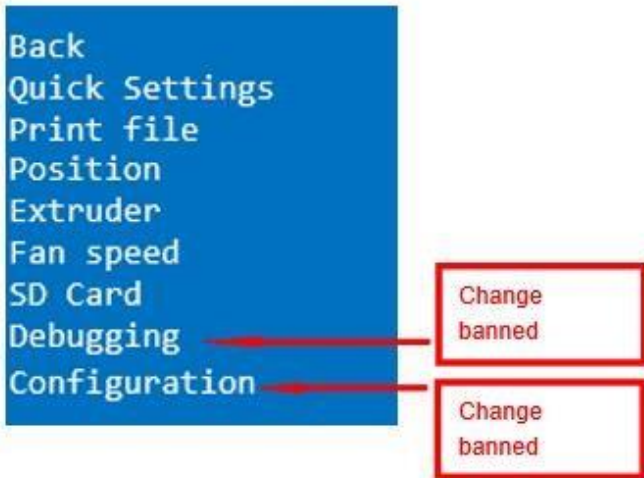

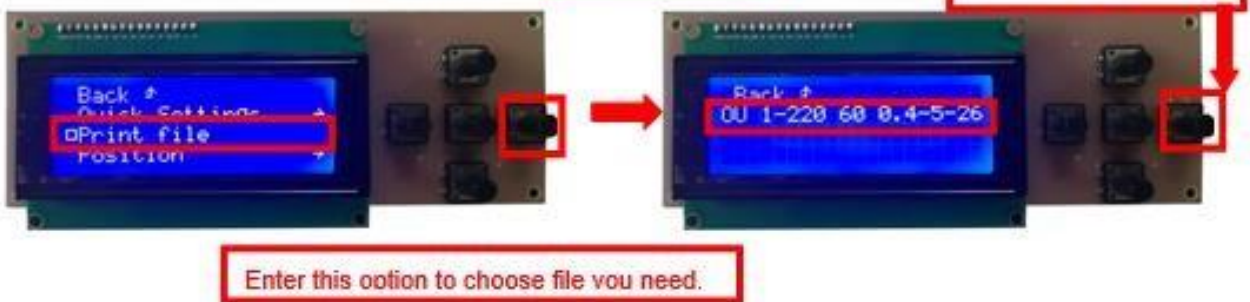
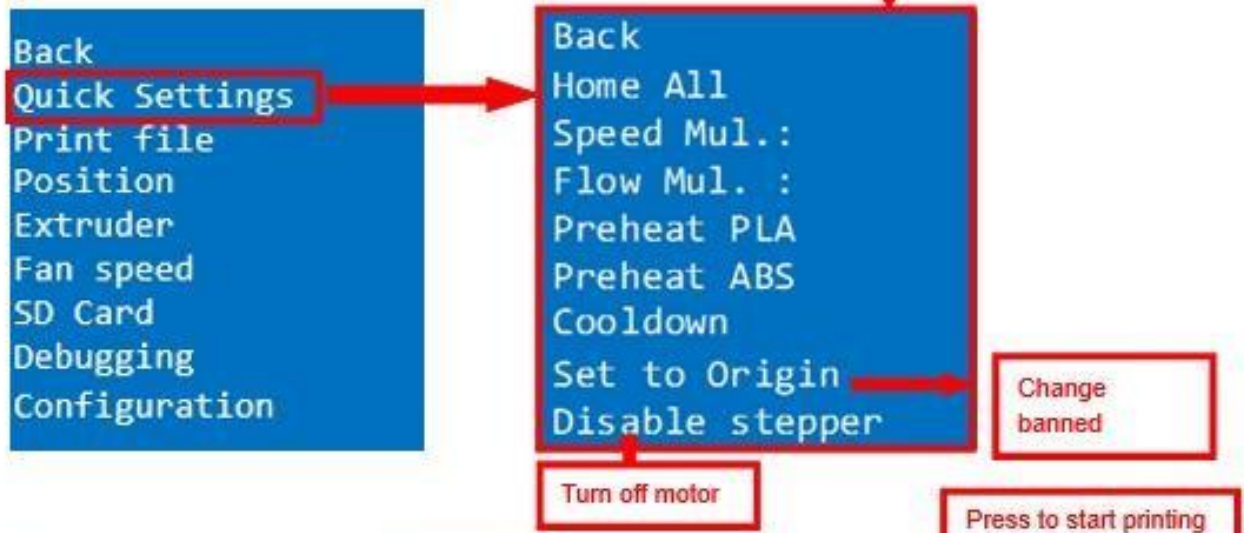
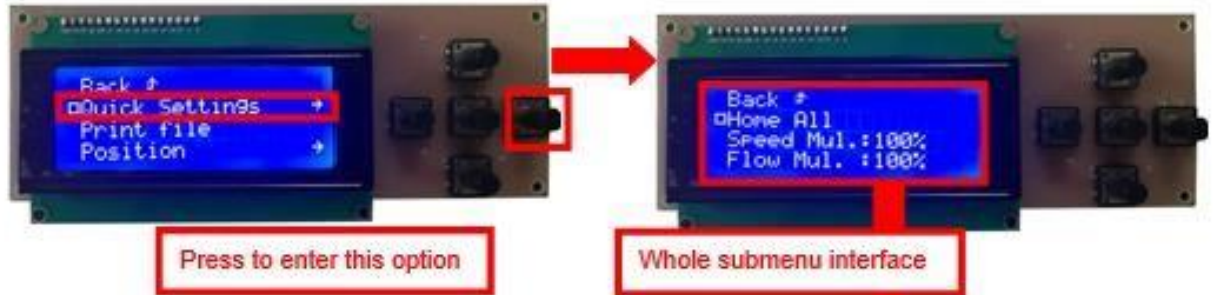

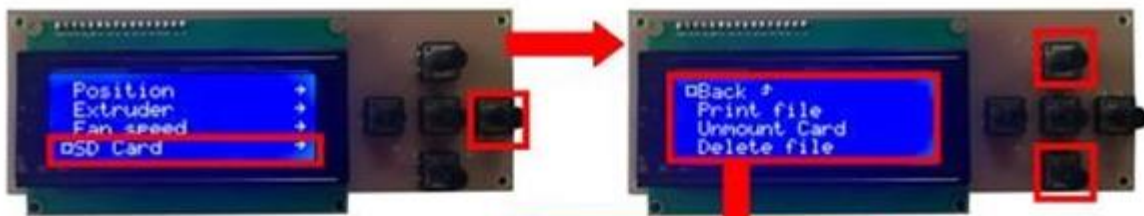

Whole interface of submenu

Back
 Quick Settings
 Print file
 Position
 Extruder
 Fan speed
 SD Card
 Debugging
 Configuration

Enter TF card before printing

Back
 Print file
 Unmount Card
 Delete file

Remove TF card

Enter TF card during printing



A8 can pause print during printing , during printing , enter "TF card" → "Pause print". It will stop printing in a few seconds. If you want to continue printing , enter "TF card" → "Continue print"

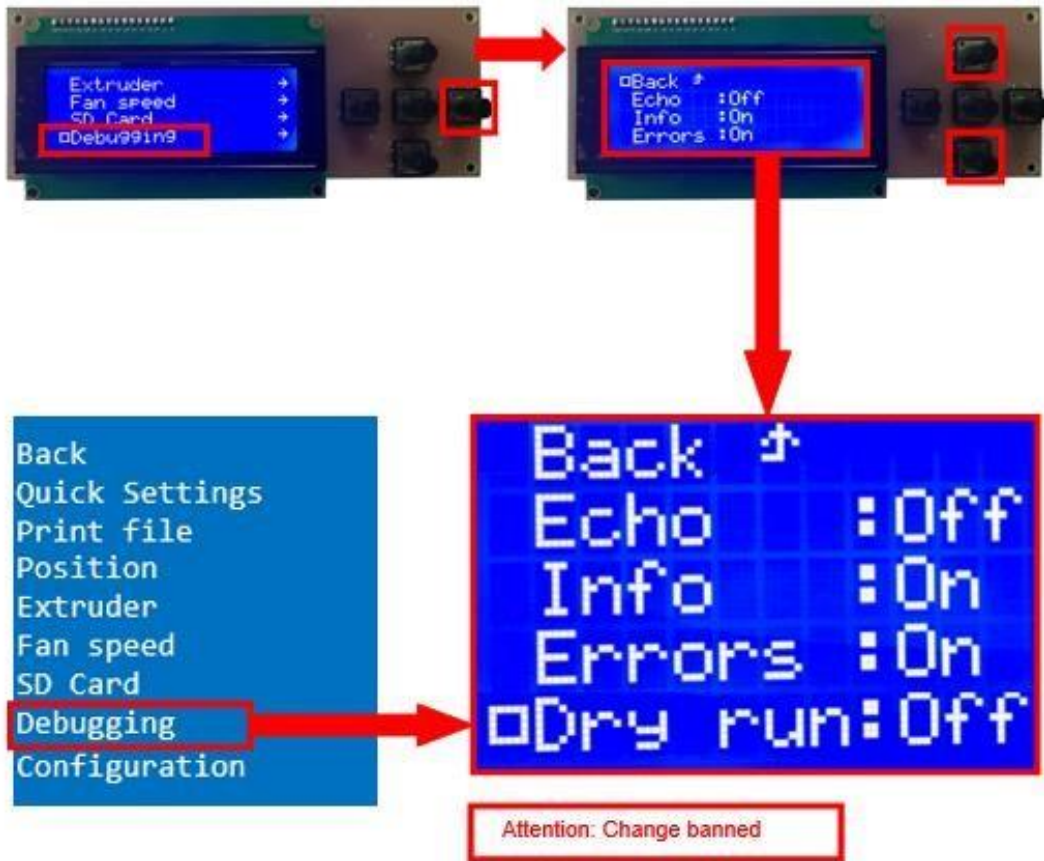

Attention: Change banned of these settings

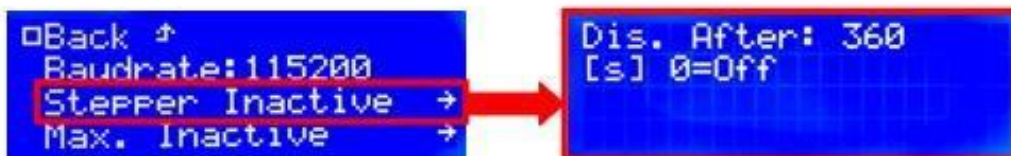
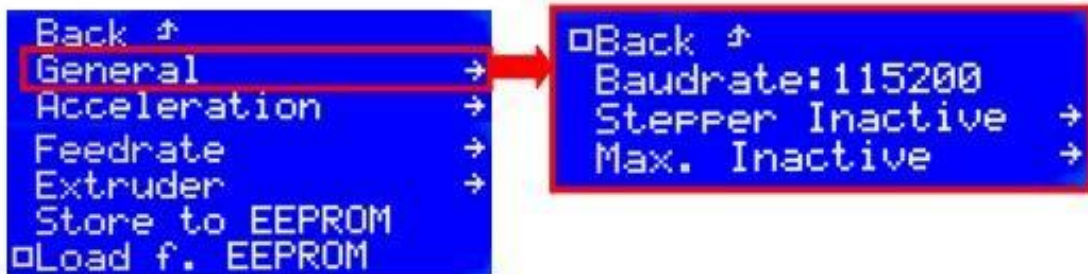
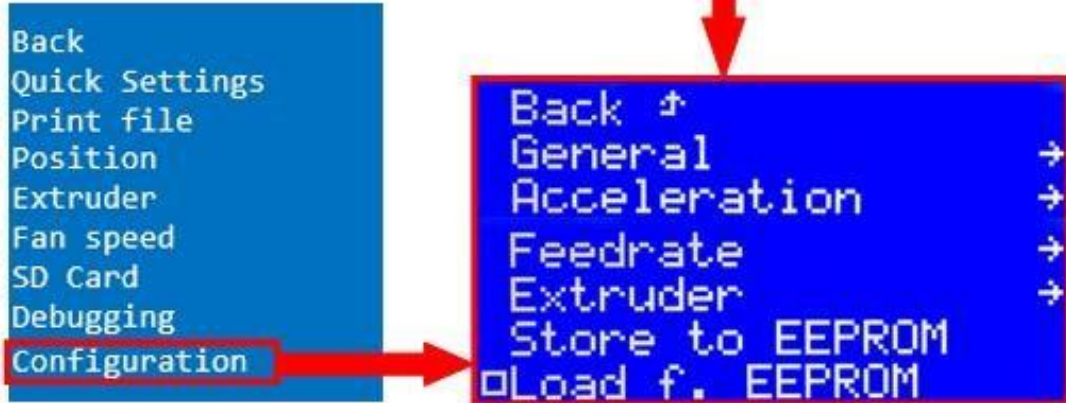
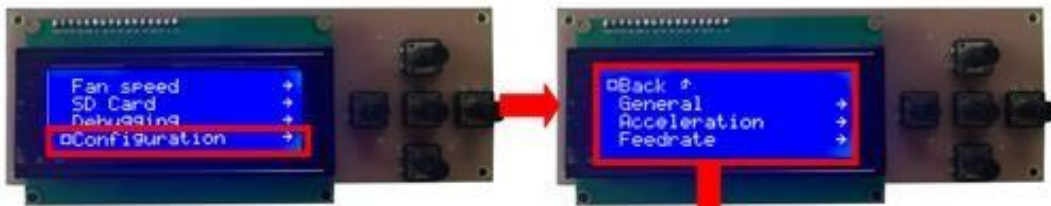

```
Back ↕
Baudrate:115200
Stepper Inactive →
Max. Inactive →
```

```
Dis. After: 0
[s] 0=Off
```

```
Back ↕
General →
Acceleration →
Feedrate →
Extruder →
Store to EEPROM
Load f. EEPROM
```

```
Back ↕
Print X: 400
Print Y: 400
Print Z: 400
-----
Move X : 400
Move Y : 400
Move Z : 400
Jerk : 20.0
Z-Jerk : 0.3
```

```
Back ↕
General →
Acceleration →
Feedrate →
Extruder →
Store to EEPROM
Load f. EEPROM
```

```
Back ↕
Max X: 400
Max Y: 400
Max Z: 8
Home X: 100
Home Y: 100
Home Z: 4
```

Attention: Change banned

```
Back ↵
General →
Acceleration →
Feedrate →
Extruder →
Store to EEPROM
Load f. EEPROM
```



```
Back ↵
Steps/MM: 95.0
Start FR: 20
Max FR: 50
Accel: 1000
Stab.Time: 1
Wait Units: 0 mm
Wait Temp. 150°C
Control:Dead Time
DT/PID P: 7.00
PID I: 2.00
PID D: 40.00
Wait Units: 0 mm
Wait Temp. 150°C
Control:Dead Time
DT/PID P: 7.00
PID I: 2.00
PID D: 40.00
Drive Min: 50
Drive Max:230
PID Max:255
```

Attention: Change banned

```
Back ↗
General →
Acceleration →
Feedrate →
Extruder →
Store to EEPROM
Load f. EEPROM
```

Configuration stored in EEPROM

```
Back ↗
General →
Acceleration →
Feedrate →
Extruder →
Store to EEPROM
Load f. EEPROM
```

Configuration loaded f. EEPROM



Attention: Change banned

2.Install Filament

2.1 Set Preheat Mode

Attention: Before filament installation, you need to preheat the printer. Use PLA as reference as below:

Press Menu → Quick Settings → Preheat PLA
The printer begins to preheat (You can back to main interface to check)

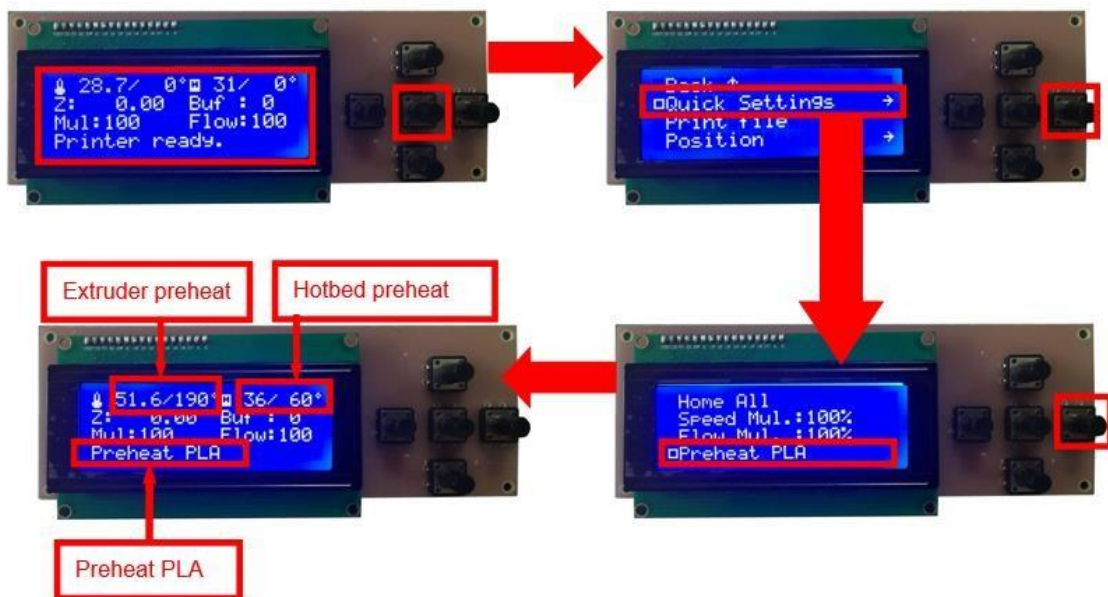

Attention: Please choose "Preheat ABS" if you want to print with ABS.

2.2 Filament Installation

Attention: Put filament into printer only when extruder temp reaches 190°C. (Use PLA as example)

Confirm Extruder Temp has reached 190°C → 1 roll PLA → Stroke the filament head straight → Press extruder screw. Meanwhile, hold the white wind mouth → Meanwhile, stick filament into the extruder quickly until filament goes out from the nozzle → Filament installation succeed

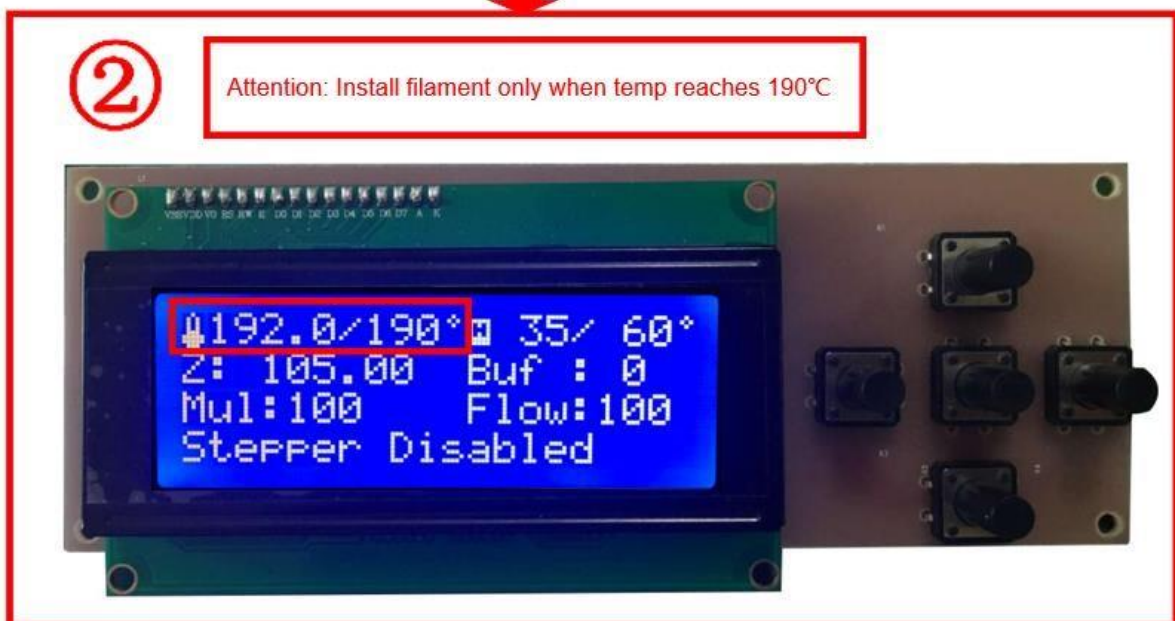



③

Stroke the filament head straight → Press extruder screw. Meanwhile, hold the white wind mouth → Meanwhile, install filament into the extruder quickly until filament liquid goes out from the nozzle

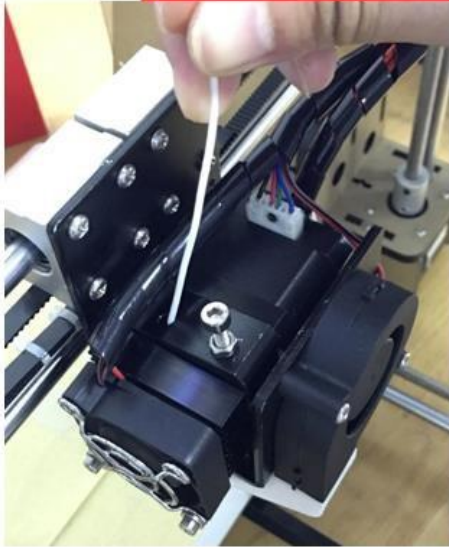

④

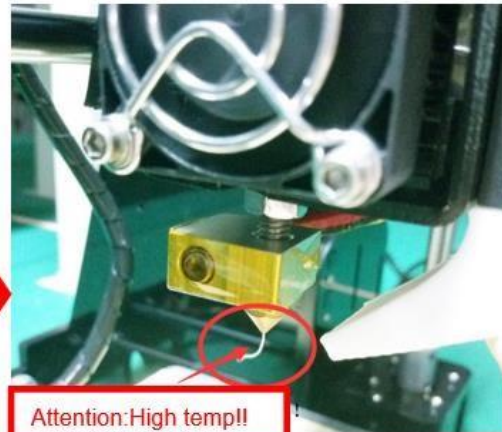

If the shape of output filament is average, means installation is good.

Press extruder screw, hold on wind mouth. Stick filament in quickly until filament goes out from extruder

Filament installation succeed

2.3 Pull out filament

When Change filament/Long-term not in use of printer , you need to pull out filament.

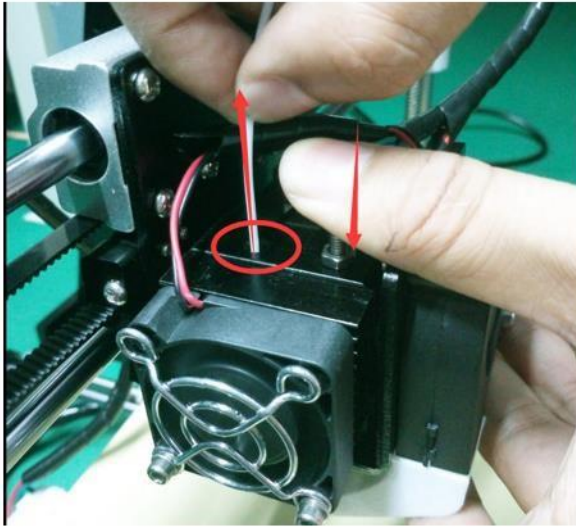

Use PLA as example

1. Preheat extruder to 190°C
2. Press extruder screw, hold wind mouth. Meanwhile, stick filament down for a few length, then pull out with average speed.

Precautions:

1. Do not stick down for long length in order to avoid failure of pulling out. Replace filament timely.
2. Please confirm you have preheated the extruder to 190°C. Do not pull out before 190°C , or it will cause irreparable damage.

3. Platform Adjustment

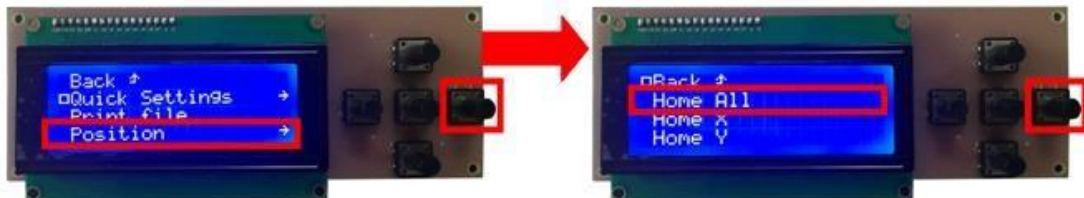

1. Choose "Position" → "Home all" , printer will move to limited switch until it stops.

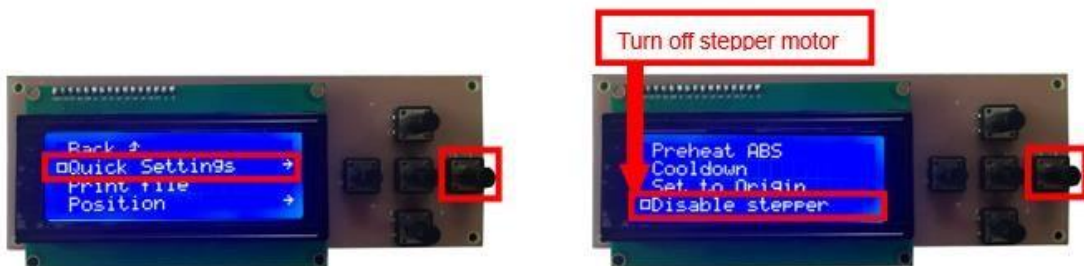

2. Turn off stepper motor: based on step 1 , enter "Quick settings" → "Disable stepper"

3. Please manually move nozzle to platform and check the gap between nozzle and platform.

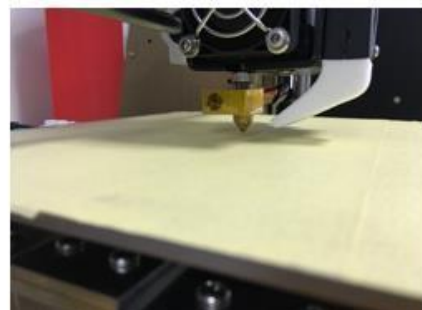

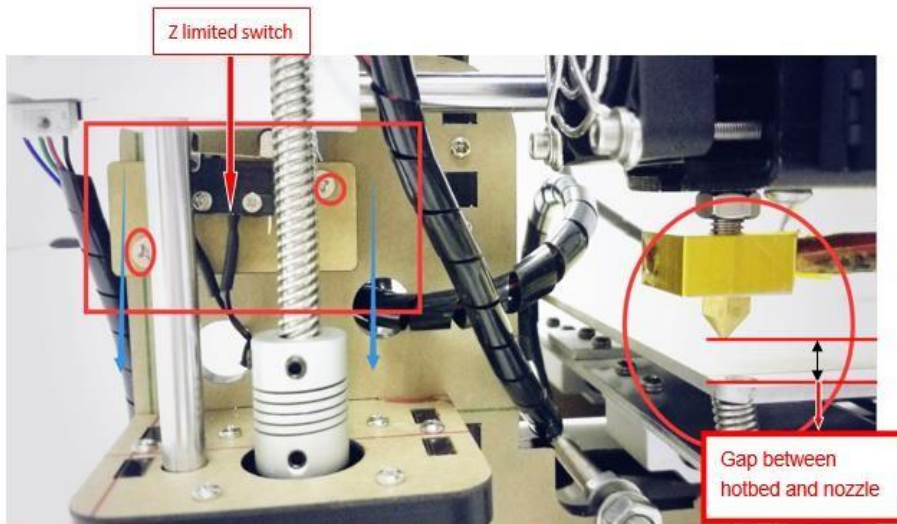

4. When the gap is more than 2mm, you need to adjust the height of Z limited switch.
 Example: When the gap is 12mm, you need to adjust limited switch down by 10mm. The rest 2mm can adjust by spring on the hotbed.

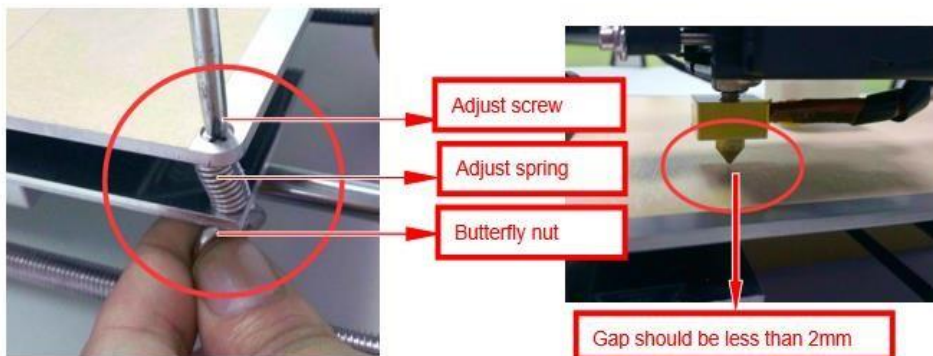

After adjustment of Z limited switch, you need to reset printer and turn off stepper motor, move extruder to the center. You can check the gap better with these conditions.

5. Adjust the gap to about 0.2mm to satisfy printing needs. Move extruder to a corner of platform, adjust the springs one by one. Use 1 or 2 A4 paper to test if they can go through the gap with some resistance.

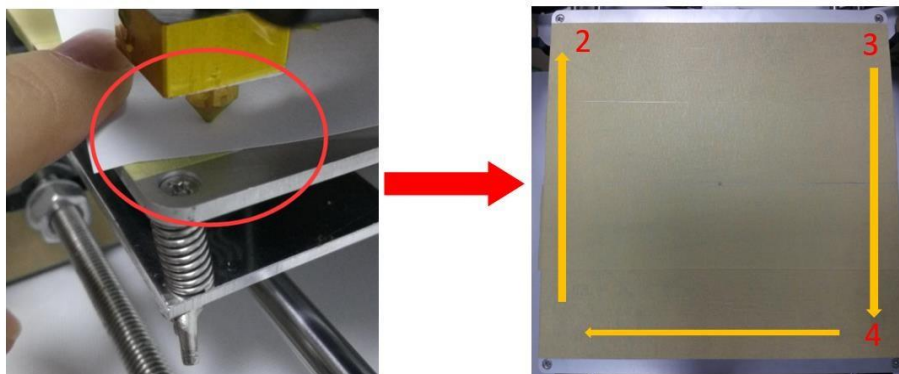

After adjustment of springs, reset printer and close stepper motor to test. Use A4 paper to test the gap.
 Tips: When you are familiar with the printer with time going by, we can adjust while it's printing. It's because the printing speed is slow at the beginning so that there's enough time for adjustment. Meanwhile, the printing effect will be better.

4. Printing

1) TF Card Offline Printing a.

Loading mode

Cura supports STL file & G-code file.

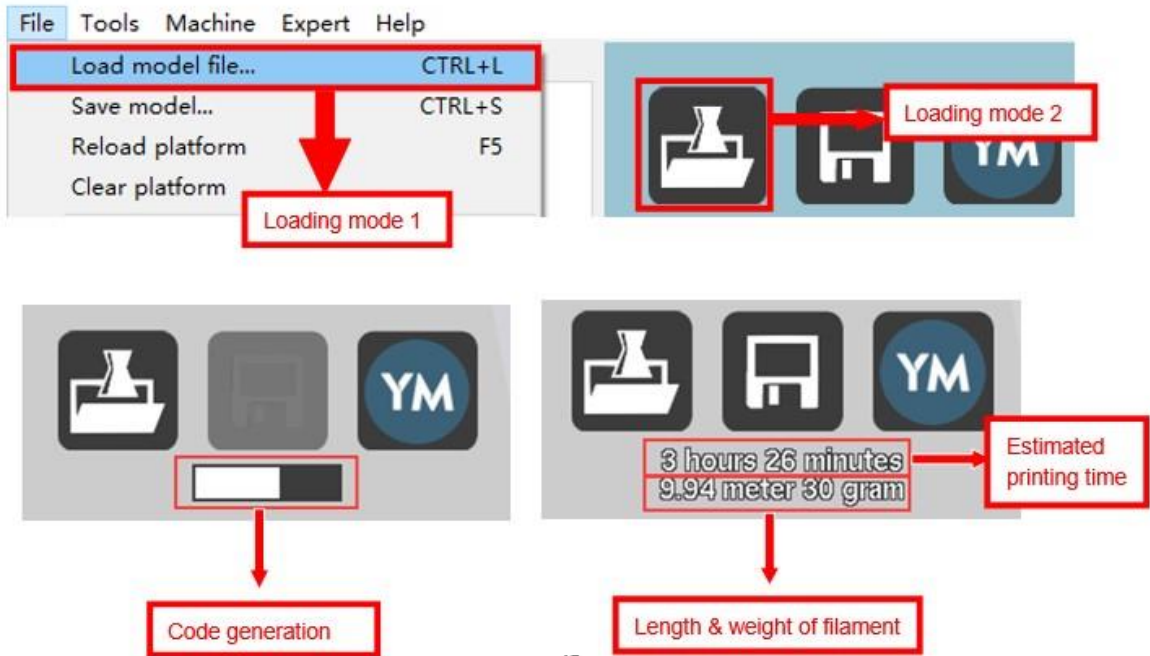

17

b. Code Saving

Copy file to TF card . Then connect TF card to printer, click reset. Picture below shows the location of print file , there are 2 methods to find print file.

c. Introduction of Stop print , Pause print , Continue Print:

Only when the printer is printing can we use Stop print, Pause print, Continue Print.

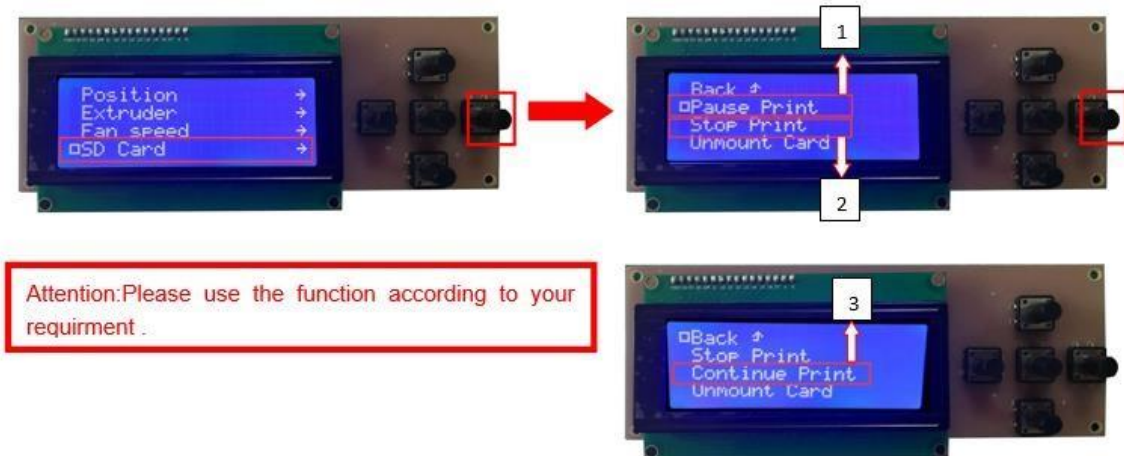

Back
Quick Settings
Print file
Position
Extruder

d. Print model

The printer will start printing automatically when the extruder & hotbed reaches estimated temp after you choose print model .

Attention: If the print bottom fails to stick to platform tight , you can adjust the platform to make it tight during printing.

e. Judgment of the gap between nozzle and platform.

1. Too big gap: The printed model is uneven, curled with gap. It means the gap is too big for filament to reach the platform, making the printing effect so bad.

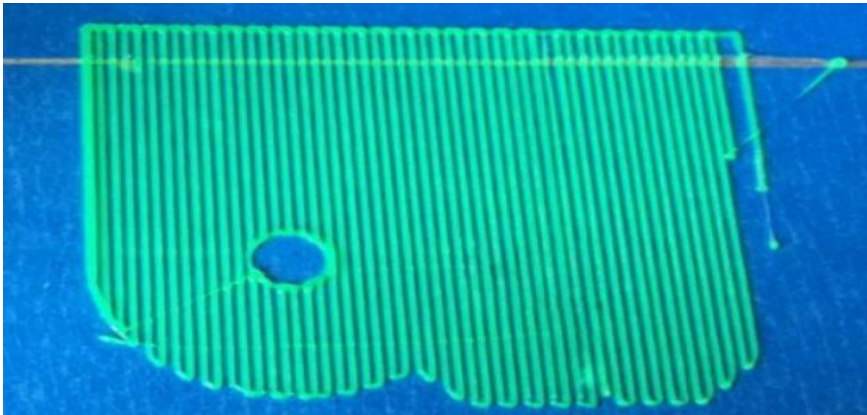

2. Too close gap: The printed model edge has irregular projections. It means the gap is too close to print normally. Sometimes it even cannot output filament

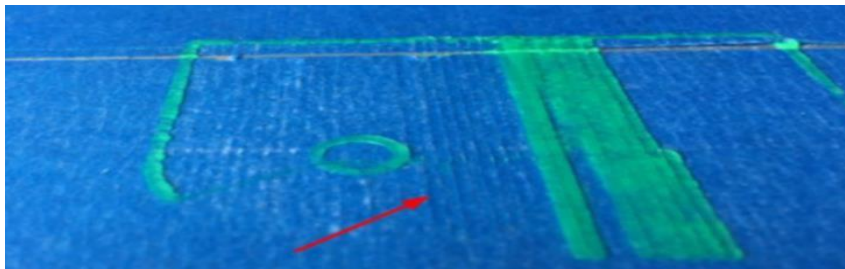

3. Appropriate distance: Printed model flat with no gap, no glitches. It means the distance is appropriate to print.

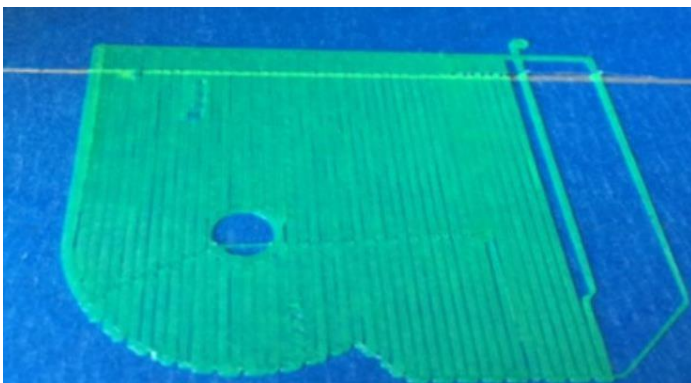

Wait to print complete after gap adjustment.

2) Online Printing

a. Machine settings (Use to connect to PC)

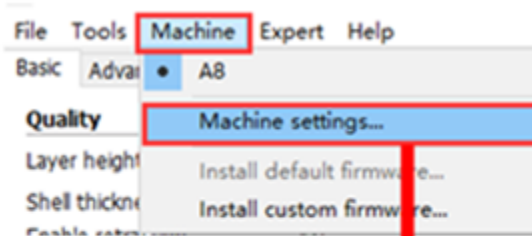
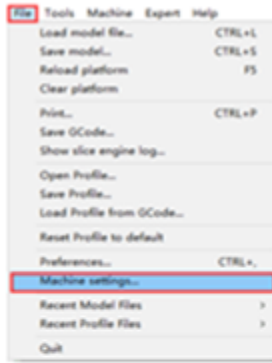

Method 1

Method 2

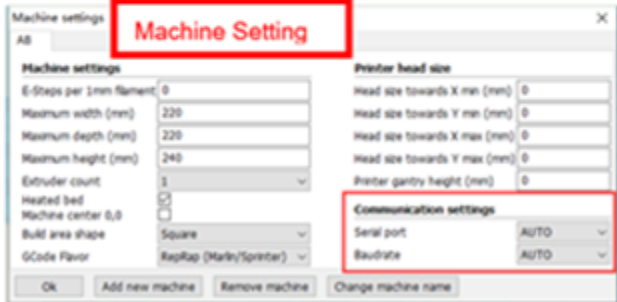

Modify serial number (serial port determined by computer), modify baud rate (usually 115200) When online printing, you need to use to connect with PC and set serial port, baudrate correctly.

b. Online Printing

Import print model, click this icon. (Icon available only when it's online)



The printer will start printing automatically when the extruder & hotbed reaches estimated temp after you choose print model. You can also modify temp in this interface.

E. FAQ and Solution

1. Z Axis Adjustment

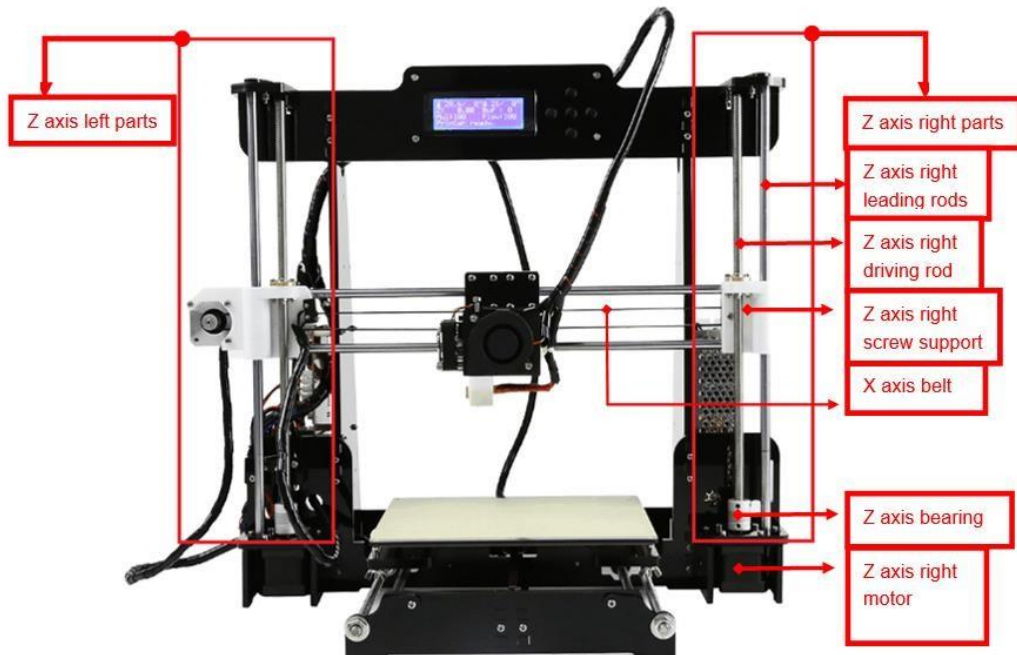

Use right Z axis for reference as shown above.
Reasons for Z axis's not smooth movement:
1. The height of both Z axis screw support is apparently different.
2. Large deviation of leading rod and motor rod's concentricity.
3. X belt is too tight.

During installation, we need to test moving parts:

1. Preparation: Before Z axis moving adjustment, please confirm the height of both Z axis screw support is the same. (Keep the same height of two white parts)

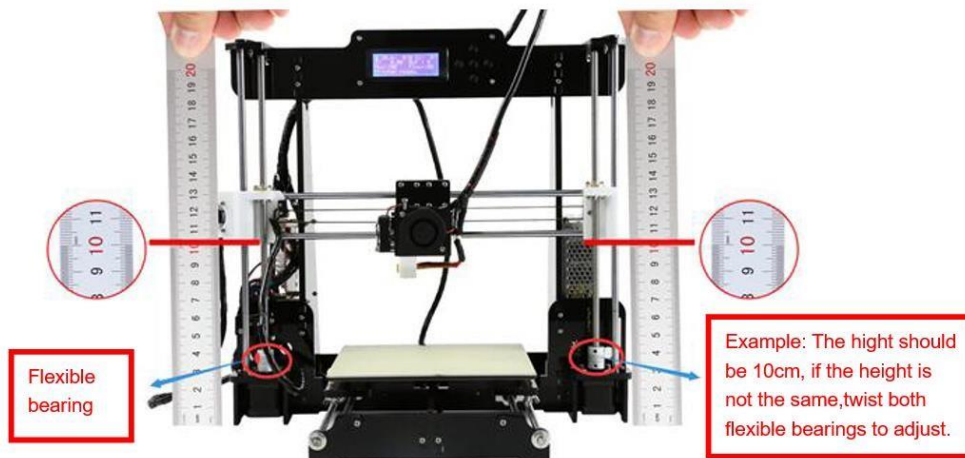

2. Adjust concentricity

1. Click to adjust Z axis to move (Position → Z pos.Fast → +/ -). If it cannot move smoothly, you need to adjust the unsmooth side's screw support. Try to keep them at the same height.
2. We can also tight/loose the Z motor screw according to requirements. This is to correct the deviation in the first time installation. Please take steps as follows to lock screws,

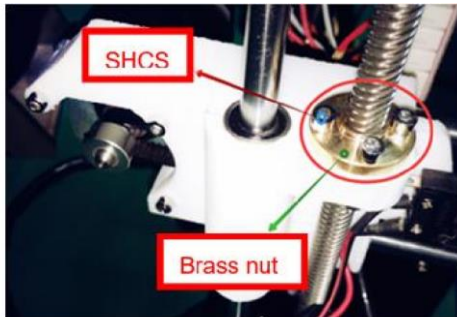

Z axis left screw support

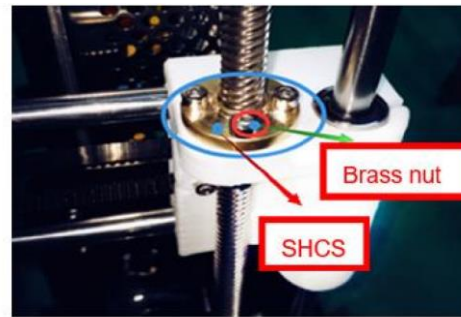

Z axis right screw support

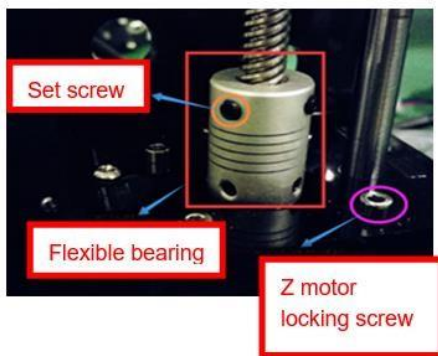

Z motor & Flexible bearing

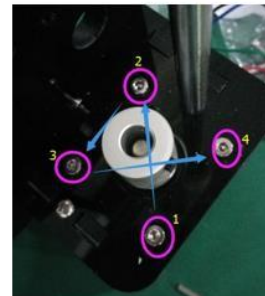

Z motor screw locking sequence

Nozzle blocking

Tips: We have removed fan to show obviously. Please consider movement according to actual requirement.

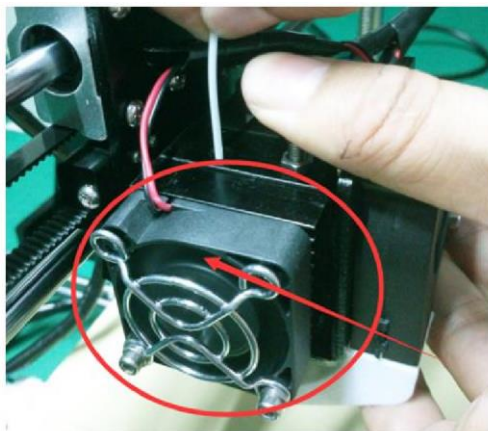

Fan

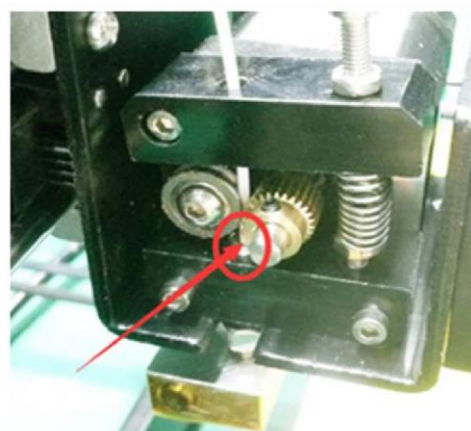

Fan removed

A. Only a little filament left in the nozzle and difficult to take out:

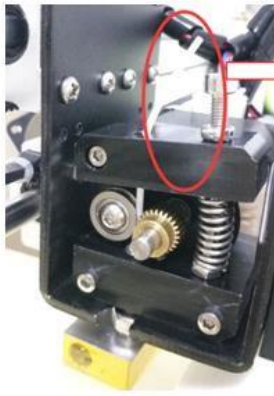

Leave filament out of spout

Choose Preheat (PLA as example) and wait temp to rise.

Operation

```
Back ↑  
□Quick Settings →  
Print file  
Position →
```

```
Home All  
Speed Mul.:100%  
Flow Mul.:100%  
□Preheat PLA
```

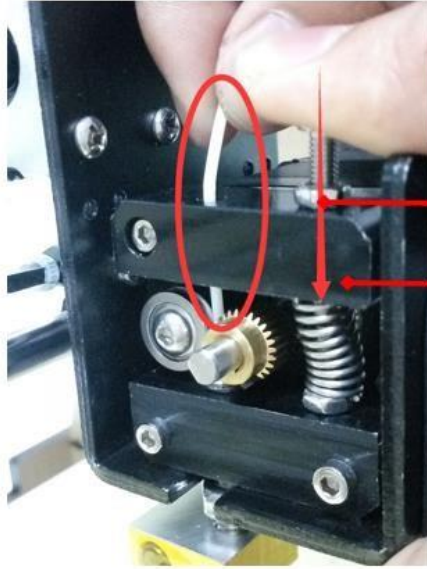

Extruder screw

Extruder briquetting

B. Filament full filled in spout

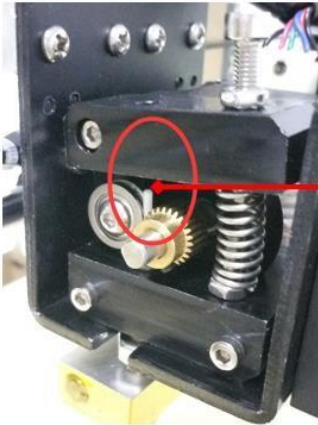

Leave filament in the spout

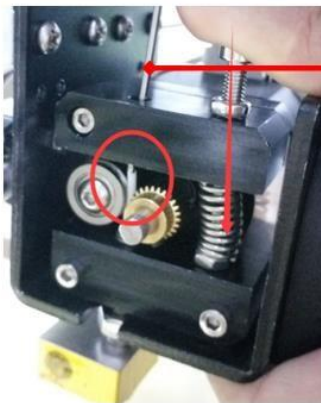

Allen wrench

Use the minimum allen wrench or some filament (1.75mm), press aligned with the remnant filament until filament comes out through nozzle.

3. FAQ

No.	Symptom	Reason	Method
1	Print model dislocation	Synchronous wheel/belt loose.	Tighten set screws or fasten belt
2	Glitch with the print model	Too high temp or slicing problem.	Extruder temp is too high and retracting speed & distance is too small
3	Foamy print model	Low temp or not smooth filament entering.	Rise extruder temp or check if brass nut and bearing is good. Replace a nozzle if methods above can't solve the problem.
4	Printer model is warped	Hotbed level isn't well adjusted.	Adjust hotbed
5	Unavailable Gcode transformation	Wrong setting/wrong save path	Choose right machine type and change the right path
6	Software installation failed	Different OS	Reset OS
7	Unusual temp	Broken temp sensor	Change a new one

F. Maintenance

Important maintenance tips:

1. maintenance of X,Y,Z axis: Add some lubricants on the rods to reduce friction when the machine works noisy and a little bit shake.
2. Please refer to the USER MANUAL before printing, do preparation of hot bed adjustment first.
3. When finished printing, the filament should keep sealing, avoid moisture.
4. Preheat the extruder at the beginning of 2 nd time printing, let extruder auto-push filament for a while.
5. Machine should do some regular maintenance, drop some lubricating oil on thread rod, polished rod and bearings to avoid fatigue wear.
6. Do not let the fan and air-condition blow to the hot bed when printing.
7. Keep the working condition at “Temp:10-30°C, Humidity:20-70%”.

G. Maintenance policy

1. This product executes regulations of “Product Warranty Card”.
2. Please contact supplier or customer service if the product have any problems . Do not repair it by yourself, otherwise you need to bear all the consequences.