

Brainz: PCB Assembly

Intro:

The purpose of this section is to drill and assemble the PCB.

Bill of Materials:

Name	Number
M3 x 0.5 mm Thread, 10 mm Long	3
M3 nuts	3
Single 80/20® Mounts	6
6-32 Zinc-Plated Socket Head Machine Screws, $\frac{3}{4}$ "	4

Step 1:

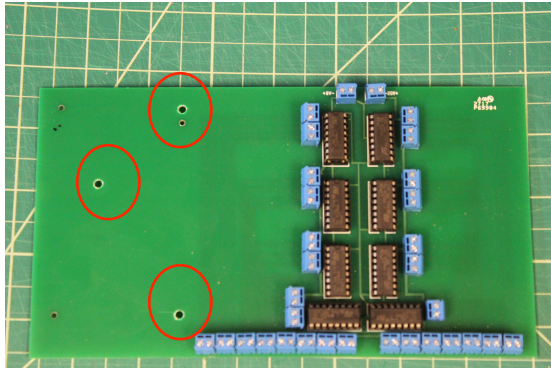

Line up the Arduino with the bottom two holes. Use it to mark these three holes, as there are only 3 holes on the Arduino that can fit M3 bolts. Pre-drill the holes with a 5/64 bit, then drill with a 9/64 bit.

Step 2:

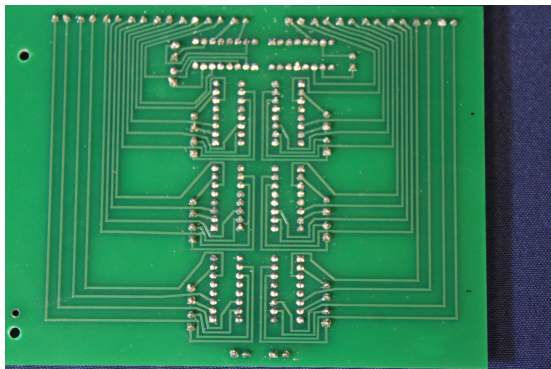

Holding your PCB up to the four L Brackets it must attach to, mark the spots on your PCB to drill.

Step 3:

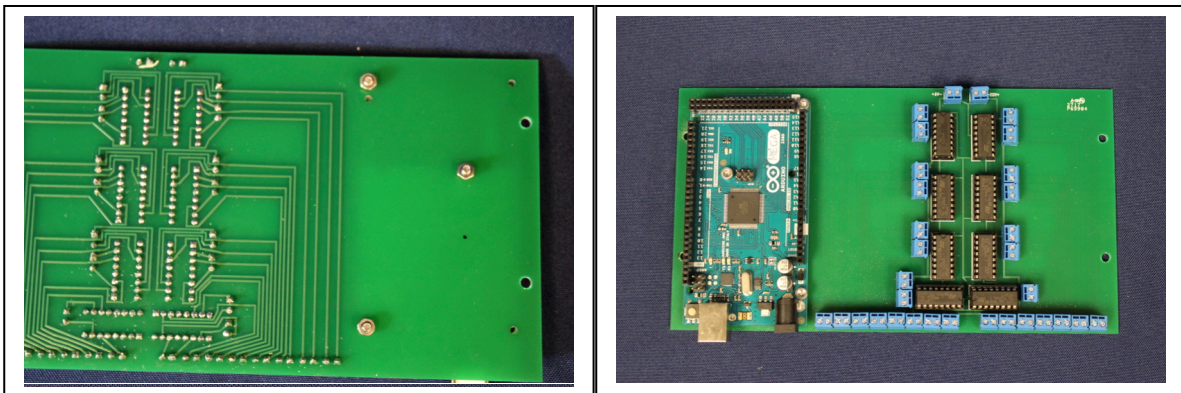

Need:

- 3x M3 bolts, 10mm long
- 3x M3 nuts

Bolt your Arduino onto the PCB. Make sure not to screw them in too hard and create tension in the boards.

Step 4:

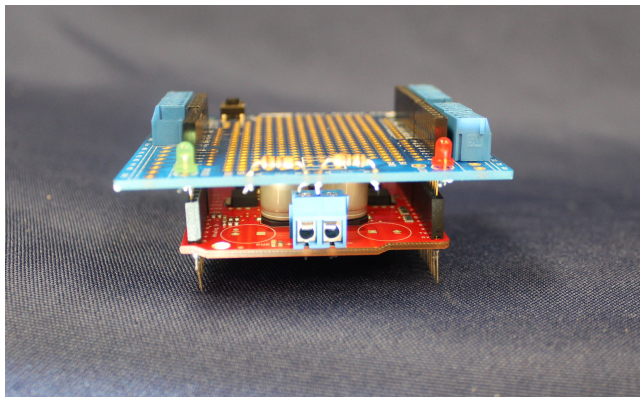
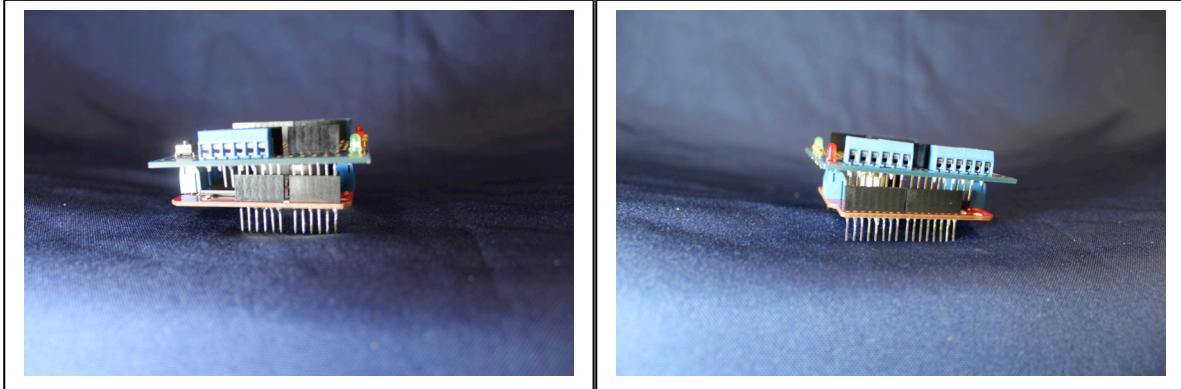

Need:

- Completed Screw Shield
- Completed Motor Shield

Connect the Motor and Screw Shield. The screw shield should go on top, with the end with LEDs on the Screw Shield and the end with the single Screw Terminal on the same side, lined up. There should be several extra leads on the other side.

Step 5:

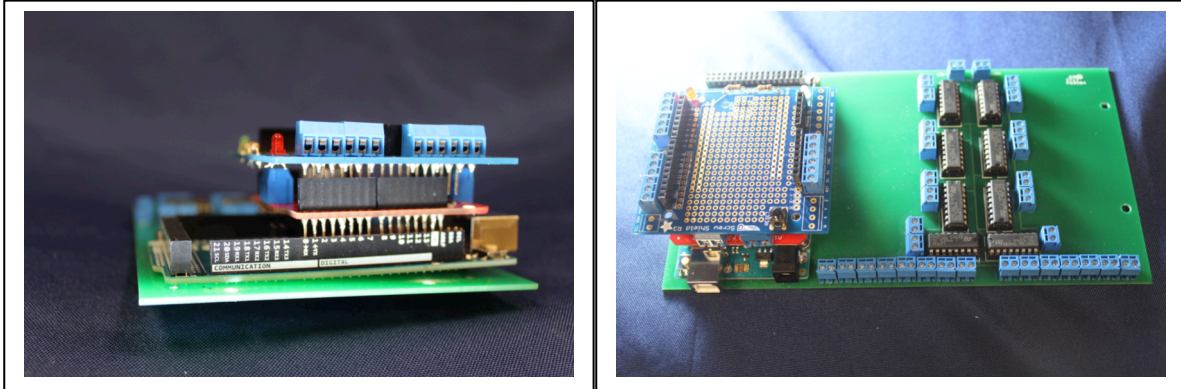

Need:

- Completed PCB with attached Arduino

Connect the motor shield into the Arduino, putting the corner with the red LED into pin 0 on the Arduino.

Step 6:

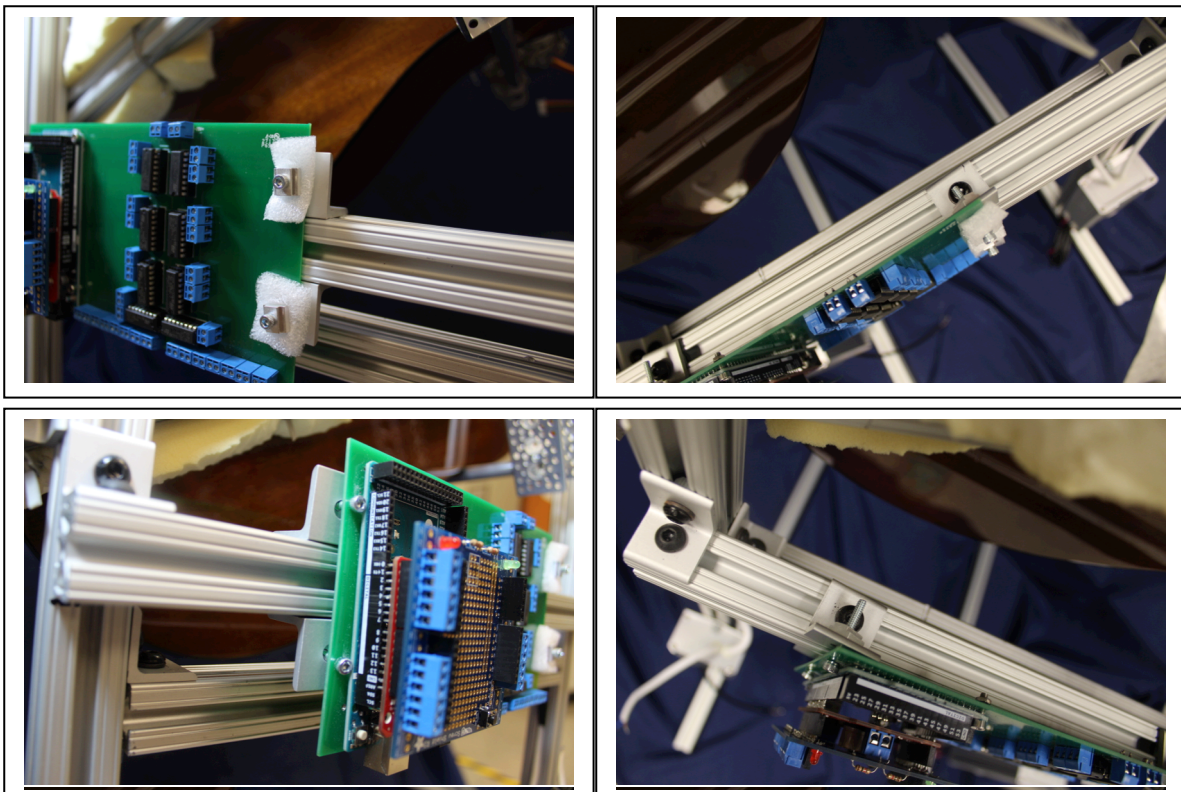

Need:

- 2x Foam from IC Socket
- 8x Single 80/20® Mounts
- 4x 6-32 Zinc-Plated Socket Head Machine Screws

To attach the PCB to the frame, shift the L Brackets until they fall underneath the four drilled holes. Then, screw one mount to the end of two of the screws, followed by a piece of foam. Pass these screws through the PCB on the side further from the Arduino. Then, pass these through the L Brackets and attach them with another mount on the back.

For the other side, pass the screw through the PCB and L Bracket. Attach the screw with a mount on the back.