

6

5

4

3

2

1

D

D

C

C

B

B

A

A

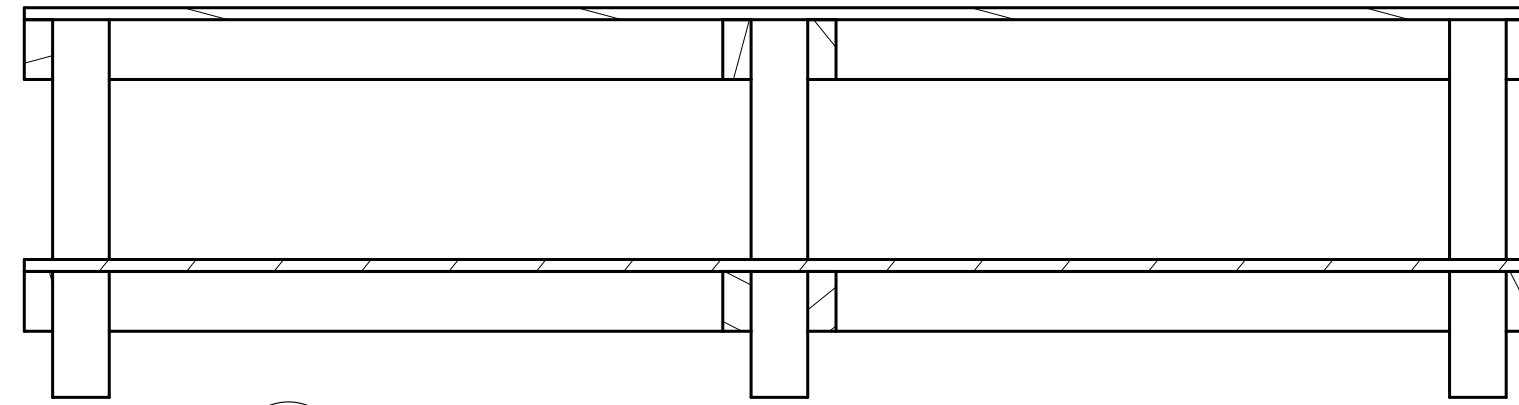
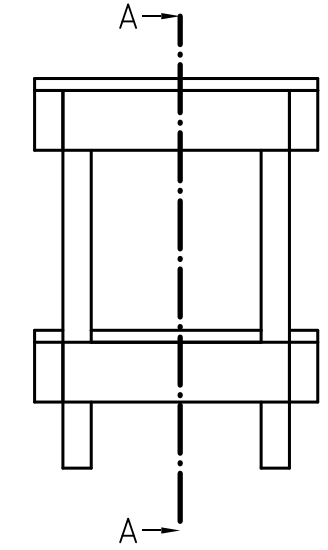
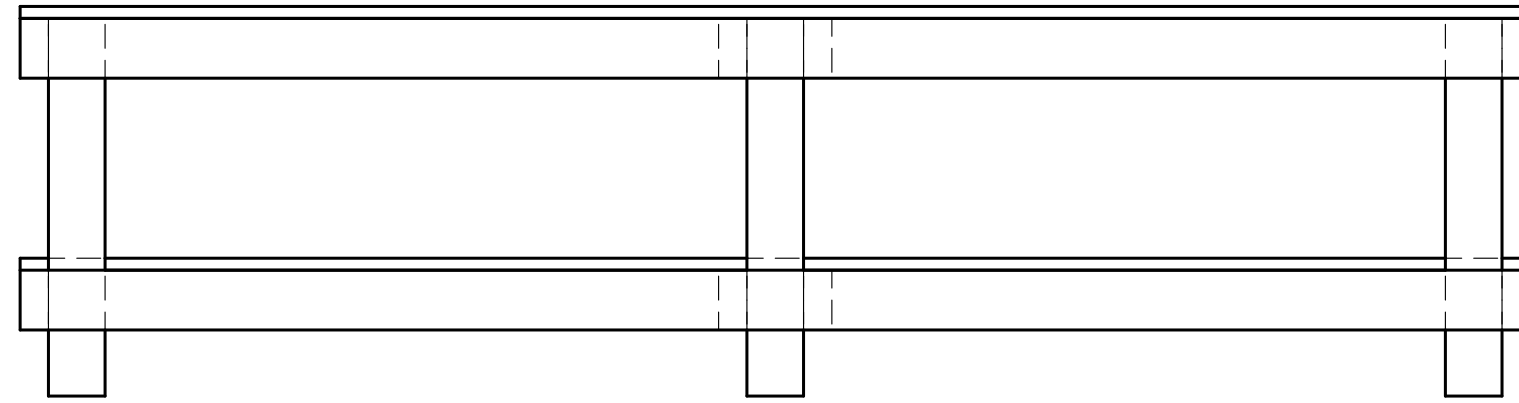

SECTION A - A

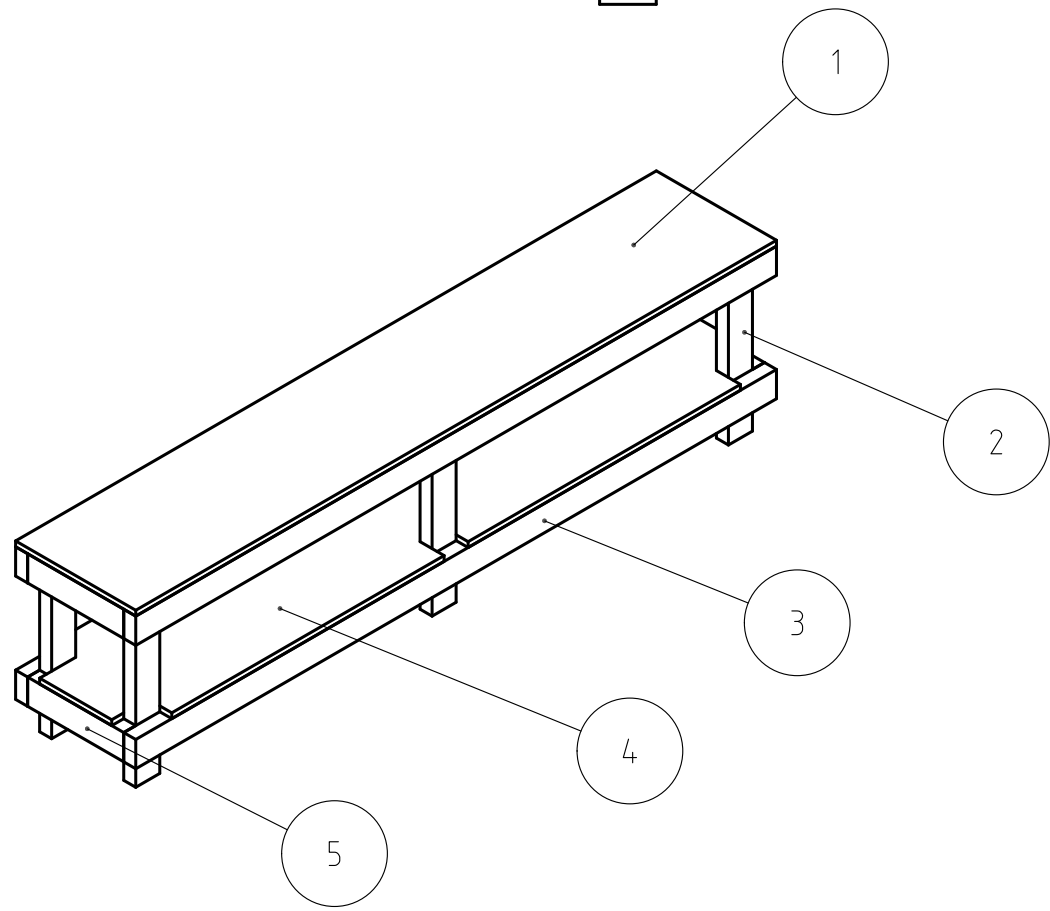

Bill of materials			
No.	Description	DWG No.	QTY.
1	Table Top	1111-01	1
2	Leg	1111-03	6
3	Long support	1111=02	4
4	Shelf	1111-05	1
5	Short support	1111-04	8

UNLESS OTHERWISE SPECIFIED, DIMENSIONS ARE IN MILLIMETERS ANGULARZ = ± ° FRACTIONAL = ± SURFACE FINISH ✓ DO NOT SCALE DRAWING BREAK ALL SHARP EDGES AND REMOVE BURRS FIRST ANGLE PROJECTION 	NAME	SIGNATURE	DATE
	DRAWN	Matt McLeod	2016-04-25
	CHECKED		
	APPROVED		
MATERIAL	FINISH		

KRANK ENGINEERING			
TITLE Build table - Assembly Drawing			
SIZE A3	DWG NO. 1111-06	REV. -	
SCALE	WEIGHT	SHEET 1 of 1	

6

5

4

3

2

1