

4	1037-PE	2	Runway	3	A
3	1037-CA01	2	Small spacer	5	A
2	1037-CA02	2	Large spacer	5	A
1	1037-PL	1	Main plate	5	A
N°	Reference	Qty	Description	Thick. (mm)	Rev.

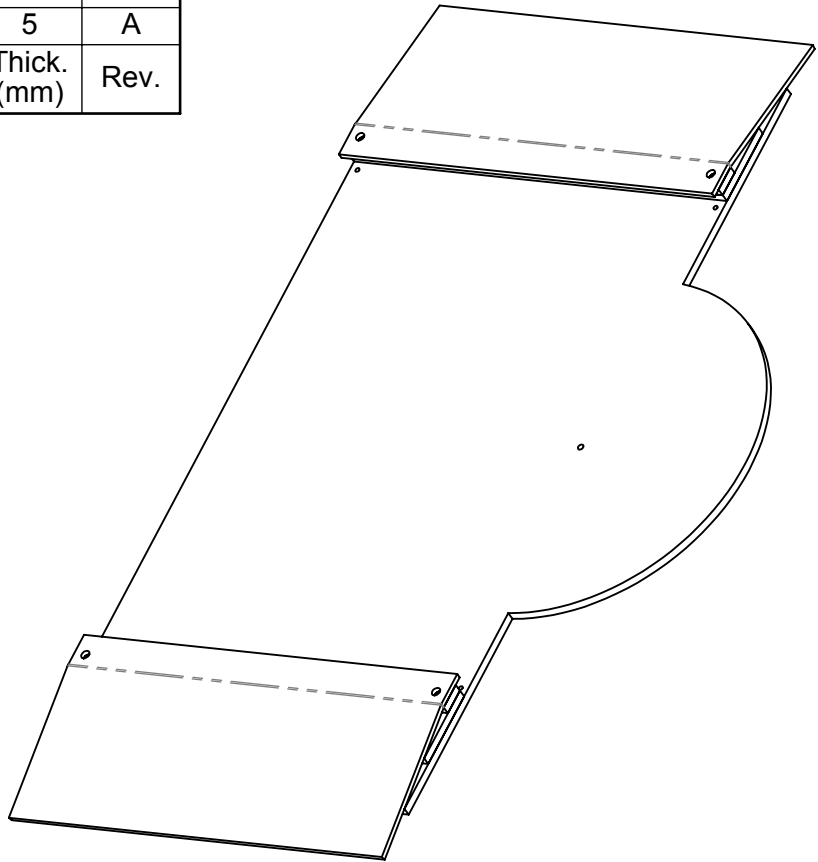
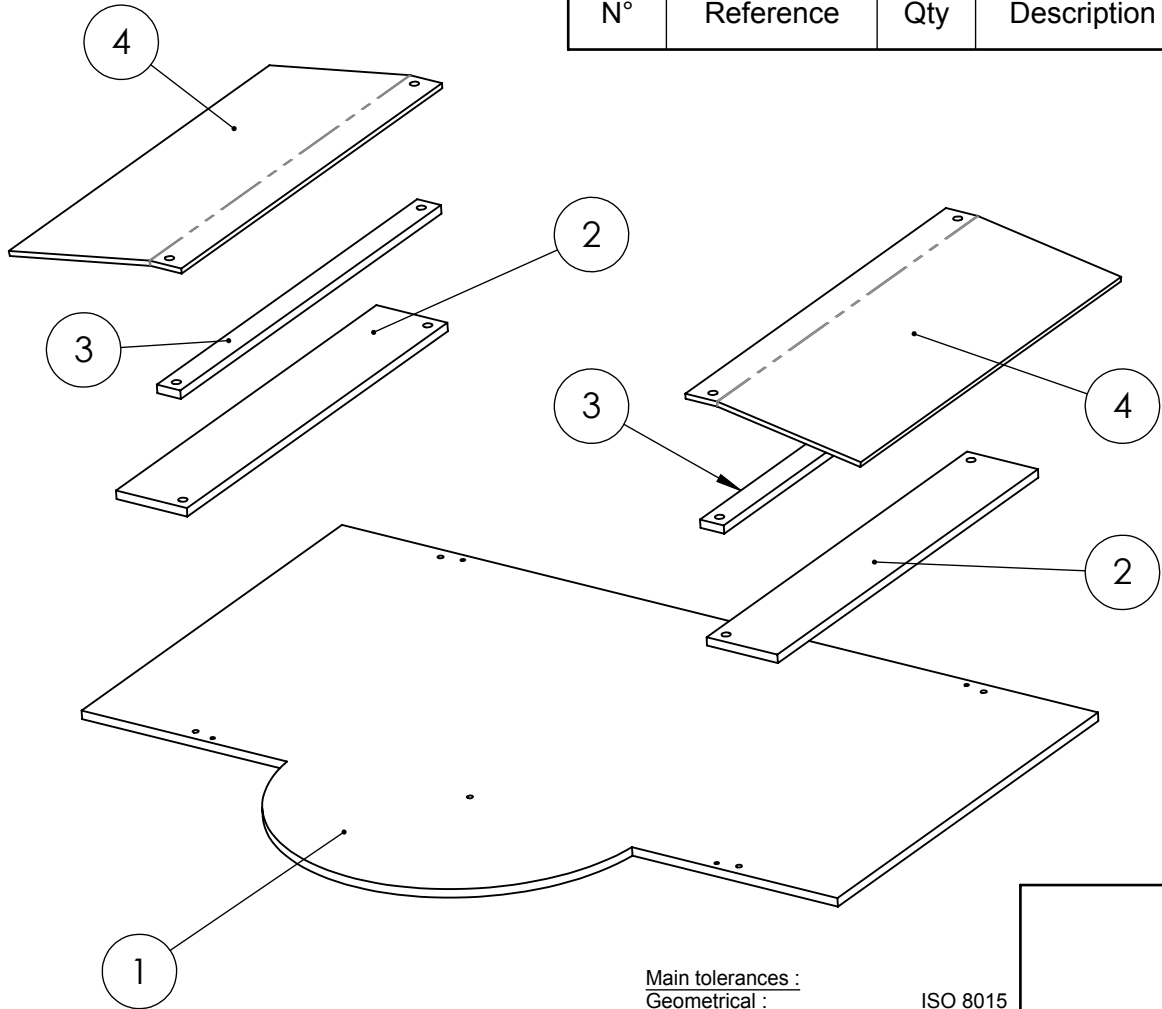

Main tolerances :  
 Geometrical : ISO 8015  
 Bended parts : NF E 86-050  
 Machining parts : ISO 2768 - mK  
 Surface roughness : 12,5 µm  
 Welded assembly : ISO 13920 CL-A

Project :		WHEEL ALIGNMENT TOOL		
Title :		Fix plate		
Reference :		1037-BA		Rev. <b>A</b>
Material :	Finish / treatment :	Mass : 2.8 kg	Scale 1:4	Frame <b>A4</b>
<small>This is property of Tanguy Le Bars, any reproduction, copy, or use of this document without a written autorisation is deemed to a penal procede</small>				

A	08/02/2019	T. Le Bars	T. Le Bars	T. Le Bars	First emission
Rev.	Date	Designed	Checked	Approuved	Comments

1  
2  
3  
4